

STATE OF NORTH CAROLINA  
DEPARTMENT OF TRANSPORTATION  
RALEIGH, N.C.

C204053

CONTRACT AND  
CONTRACT BONDS

FOR CONTRACT NO. C204053

WBS 53032.3.1 NHPP-0085(017)

T.I.P NO. I-5793

COUNTY OF DAVIDSON

THIS IS THE ROADWAY & STRUCTURE CONTRACT

ROUTE NUMBER I85 LENGTH 7.165 MILES

LOCATION I-85 FROM EAST OF US-64 TO NC-109 IN THOMASVILLE.

CONTRACTOR TRIANGLE GRADING & PAVING INC

ADDRESS P.O. BOX 2570

BURLINGTON, NC 27216

BIDS OPENED JANUARY 16, 2018

CONTRACT EXECUTION 2/7/2018

STATE OF NORTH CAROLINA  
DEPARTMENT OF TRANSPORTATION  
RALEIGH, N.C.

PROPOSAL

DATE AND TIME OF BID OPENING: **JANUARY 16, 2018 AT 2:00 PM**

CONTRACT ID C204053  
WBS 53032.3.1

FEDERAL-AID NO. NHPP-0085(017)  
COUNTY DAVIDSON  
T.I.P. NO. I-5793  
MILES 7.165  
ROUTE NO. I 85  
LOCATION I-85 FROM EAST OF US-64 TO NC-109 IN THOMASVILLE.

TYPE OF WORK PAVEMENT REHABILITATION AND BRIDGE PRESERVATION.

**NOTICE:**

ALL BIDDERS SHALL COMPLY WITH ALL APPLICABLE LAWS REGULATING THE PRACTICE OF GENERAL CONTRACTING AS CONTAINED IN CHAPTER 87 OF THE GENERAL STATUTES OF NORTH CAROLINA WHICH REQUIRES THE BIDDER TO BE LICENSED BY THE N.C. LICENSING BOARD FOR CONTRACTORS WHEN BIDDING ON ANY NON-FEDERAL AID PROJECT WHERE THE BID IS \$30,000 OR MORE, EXCEPT FOR CERTAIN SPECIALTY WORK AS DETERMINED BY THE LICENSING BOARD. BIDDERS SHALL ALSO COMPLY WITH ALL OTHER APPLICABLE LAWS REGULATING THE PRACTICES OF ELECTRICAL, PLUMBING, HEATING AND AIR CONDITIONING AND REFRIGERATION CONTRACTING AS CONTAINED IN CHAPTER 87 OF THE GENERAL STATUTES OF NORTH CAROLINA. NOTWITHSTANDING THESE LIMITATIONS ON BIDDING, THE BIDDER WHO IS AWARDED ANY FEDERAL - AID FUNDED PROJECT SHALL COMPLY WITH CHAPTER 87 OF THE GENERAL STATUTES OF NORTH CAROLINA FOR LICENSING REQUIREMENTS WITHIN 60 CALENDAR DAYS OF BID OPENING.

**BIDS WILL BE RECEIVED AS SHOWN BELOW:**

**THIS IS A ROADWAY & STRUCTURE PROPOSAL**

**5% BID BOND OR BID DEPOSIT REQUIRED**

---

**PROPOSAL FOR THE CONSTRUCTION OF  
CONTRACT No. C204053 IN DAVIDSON COUNTY, NORTH CAROLINA**

Date \_\_\_\_\_ 20 \_\_\_\_\_

**DEPARTMENT OF TRANSPORTATION,  
RALEIGH, NORTH CAROLINA**

The Bidder has carefully examined the location of the proposed work to be known as Contract No. C204053 has carefully examined the plans and specifications, which are acknowledged to be part of the proposal, the special provisions, the proposal, the form of contract, and the forms of contract payment bond and contract performance bond; and thoroughly understands the stipulations, requirements and provisions. The undersigned bidder agrees to bound upon his execution of the bid and subsequent award to him by the Board of Transportation in accordance with this proposal to provide the necessary contract payment bond and contract performance bond within fourteen days after the written notice of award is received by him. The undersigned Bidder further agrees to provide all necessary machinery, tools, labor, and other means of construction; and to do all the work and to furnish all materials, except as otherwise noted, necessary to perform and complete the said contract in accordance with *the 2018 Standard Specifications for Roads and Structures* by the dates(s) specified in the Project Special Provisions and in accordance with the requirements of the Engineer, and at the unit or lump sum prices, as the case may be, for the various items given on the sheets contained herein.

The Bidder shall provide and furnish all the materials, machinery, implements, appliances and tools, and perform the work and required labor to construct and complete State Highway Contract No. C204053 in Davidson County, for the unit or lump sum prices, as the case may be, bid by the Bidder in his bid and according to the proposal, plans, and specifications prepared by said Department, which proposal, plans, and specifications show the details covering this project, and hereby become a part of this contract.

The published volume entitled *North Carolina Department of Transportation, Raleigh, Standard Specifications for Roads and Structures, January 2018* with all amendments and supplements thereto, is by reference incorporated into and made a part of this contract; that, except as herein modified, all the construction and work included in this contract is to be done in accordance with the specifications contained in said volume, and amendments and supplements thereto, under the direction of the Engineer.

If the proposal is accepted and the award is made, the contract is valid only when signed either by the Contract Officer or such other person as may be designated by the Secretary to sign for the Department of Transportation. The conditions and provisions herein cannot be changed except over the signature of the said Contract Officer.

The quantities shown in the itemized proposal for the project are considered to be approximate only and are given as the basis for comparison of bids. The Department of Transportation may increase or decrease the quantity of any item or portion of the work as may be deemed necessary or expedient.

An increase or decrease in the quantity of an item will not be regarded as sufficient ground for an increase or decrease in the unit prices, nor in the time allowed for the completion of the work, except as provided for the contract.

Accompanying this bid is a bid bond secured by a corporate surety, or certified check payable to the order of the Department of Transportation, for five percent of the total bid price, which deposit is to be forfeited as liquidated damages in case this bid is accepted and the Bidder shall fail to provide the required payment and performance bonds with the Department of Transportation, under the condition of this proposal, within 14 calendar days after the written notice of award is received by him, as provided in the *Standard Specifications*; otherwise said deposit will be returned to the Bidder.



State Contract Officer

DocuSigned by:  
*Ronald E. Davenport, Jr.*  
F81B6038A47A442...

12/6/2017

**TABLE OF CONTENTS**

**COVER SHEET**  
**PROPOSAL SHEET**

**PROJECT SPECIAL PROVISIONS**

CONTRACT TIME AND LIQUIDATED DAMAGES: ..... G-1  
INTERMEDIATE CONTRACT TIME NUMBER 1 AND LIQUIDATED DAMAGES: ..... G-1  
PROSECUTION OF WORK:..... G-2  
MAJOR CONTRACT ITEMS: ..... G-3  
SPECIALTY ITEMS:..... G-3  
FUEL PRICE ADJUSTMENT:..... G-3  
SCHEDULE OF ESTIMATED COMPLETION PROGRESS:..... G-4  
DISADVANTAGED BUSINESS ENTERPRISE: ..... G-4  
CERTIFICATION FOR FEDERAL-AID CONTRACTS: ..... G-17  
U.S. DEPARTMENT OF TRANSPORTATION HOTLINE: ..... G-18  
CARGO PREFERENCE ACT: ..... G-18  
MAINTENANCE OF THE PROJECT: ..... G-18  
EROSION AND SEDIMENT CONTROL/STORMWATER CERTIFICATION: ..... G-19  
PROCEDURE FOR MONITORING BORROW PIT DISCHARGE:..... G-24

ROADWAY ..... R-1

**STANDARD SPECIAL PROVISIONS**

AVAILABILITY FUNDS – TERMINATION OF CONTRACTS ..... SSP-1  
NCDOT GENERAL SEED SPECIFICATION FOR SEED QUALITY ..... SSP-2  
ERRATA..... SSP-5  
PLANT AND PEST QUARANTINES ..... SSP-6  
MINORITY AND FEMALE EMPLOYMENT REQUIREMENTS ..... SSP-7  
REQUIRED CONTRACT PROVISIONS FEDERAL-AID CONST. CONTRACTS ..... SSP-10  
ON-THE-JOB TRAINING ..... SSP-19  
MINIMUM WAGES ..... SSP-22

**UNIT PROJECT SPECIAL PROVISIONS**

TRAFFIC CONTROL ..... TC-1  
EROSION CONTROL ..... EC-1  
STRUCTURE / CULVERTS..... BP-1  
RAILROAD INSURANCE (Structures) ..... BP-84

**PROPOSAL ITEM SHEET**

ITEM SHEET(S) (TAN SHEETS)

**PROJECT SPECIAL PROVISIONS****GENERAL****CONTRACT TIME AND LIQUIDATED DAMAGES:**

(7-1-95) (Rev. 12-18-07)

108

SP1 G10 A

The date of availability for this contract is **March 12, 2018**.

The completion date for this contract is **October 15, 2019**.

Except where otherwise provided by the contract, observation periods required by the contract will not be a part of the work to be completed by the completion date and/or intermediate contract times stated in the contract. The acceptable completion of the observation periods that extend beyond the final completion date shall be a part of the work covered by the performance and payment bonds.

The liquidated damages for this contract are **Two Thousand Dollars (\$ 2,000.00)** per calendar day.

**INTERMEDIATE CONTRACT TIME NUMBER 1 AND LIQUIDATED DAMAGES:**

(2-20-07)

108

SP1 G14 A

The Contractor shall complete the required work of installing, maintaining, and removing the traffic control devices for lane closures and restoring traffic to the existing traffic pattern. The Contractor shall not close or narrow a lane of traffic on **I-85 & Associated Ramps** during the following time restrictions:

**DAY AND TIME RESTRICTIONS****Monday thru Sunday****6:00am to 8:00pm**

In addition, the Contractor shall not close or narrow a lane of traffic on **I-85 & Associated Ramps**, detain and/or alter the traffic flow on or during holidays, holiday weekends, special events, or any other time when traffic is unusually heavy, including the following schedules:

**HOLIDAY AND HOLIDAY WEEKEND LANE CLOSURE RESTRICTIONS**

1. For **unexpected occurrence** that creates unusually high traffic volumes, as directed by the Engineer.
2. For **New Year's Day**, between the hours of **6:00am** December 31<sup>st</sup> and **8:00pm** January 2<sup>nd</sup>. If New Year's Day is on a Friday, Saturday, Sunday or Monday, then until **7:00pm** the following Tuesday.
3. For **Easter**, between the hours of **6:00am** Thursday and **8:00pm** Monday.
4. For **Memorial Day**, between the hours of **6:00am** Friday and **8:00pm** Tuesday.

5. For **Independence Day**, between the hours of **6:00am** the day before Independence Day and **8:00pm** the day after Independence Day.

If **Independence Day** is on a Friday, Saturday, Sunday or Monday, then between the hours of **6:00am** the Thursday before Independence Day and **8:00pm** the Tuesday after Independence Day.

6. For **Labor Day**, between the hours of **6:00am** Friday and **8:00pm** Tuesday.
7. For **Thanksgiving**, between the hours of **6:00am** Tuesday and **8:00pm** Monday.
8. For **Christmas**, between the hours of **6:00am** the Friday before the week of Christmas Day and **8:00pm** the following Tuesday after the week of Christmas Day.

Holidays and holiday weekends shall include New Year's Day, Easter, Memorial Day, Independence Day, Labor Day, Thanksgiving, and Christmas. The Contractor shall schedule his work so that lane closures will not be required during these periods, unless otherwise directed by the Engineer.

The time of availability for this intermediate contract work shall be the time the Contractor begins to install all traffic control devices for lane closures according to the time restrictions listed herein.

The completion time for this intermediate contract work shall be the time the Contractor is required to complete the removal of all traffic control devices for lane closures according to the time restrictions stated above and place traffic in the existing traffic pattern.

The liquidated damages are **Five Hundred Dollars (\$ 500.00)** per fifteen (**15**) minute time period.

#### **PROSECUTION OF WORK:**

(7-1-95) (Rev. 8-21-12)

108

SP1 G15R

The Contractor will be required to prosecute the work in a continuous and uninterrupted manner from the time he begins the work until completion and final acceptance of the project. The Contractor will not be permitted to suspend his operations except for reasons beyond his control or except where the Engineer has authorized a suspension of the Contractor's operations in writing.

In the event that the Contractor's operations are suspended in violation of the above provisions, the sum of **\$ 2,000.00** will be charged the Contractor for each and every calendar day that such suspension takes place. The said amount is hereby agreed upon as liquidated damages due to extra engineering and maintenance costs and due to increased public hazard resulting from a suspension of the work. Liquidated damages chargeable due to suspension of the work will be additional to any liquidated damages that may become chargeable due to failure to complete the work on time.

**MAJOR CONTRACT ITEMS:**

(2-19-02)

104

SP1 G28

The following listed items are the major contract items for this contract (see Article 104-5 of the *2018 Standard Specifications*):

<b>Line #</b>	<b>Description</b>
18 —	Diamond Grinding PCC Pavement
20 —	Roller Compacted Concrete

**SPECIALTY ITEMS:**

(7-1-95)(Rev. 1-17-12)

108-6

SP1 G37

Items listed below will be the specialty items for this contract (see Article 108-6 of the *2018 Standard Specifications*).

<b>Line #</b>	<b>Description</b>
17 - 18 & 20	Paving
36 & 40 - 41	Long-Life Pavement Markings
45	Permanent Pavement Markers
47 - 49	Erosion Control

**FUEL PRICE ADJUSTMENT:**

(11-15-05) (Rev. 2-18-14)

109-8

SP1 G43

Revise the *2018 Standard Specifications* as follows:

**Page 1-83, Article 109-8, Fuel Price Adjustments**, add the following:

The base index price for DIESEL #2 FUEL is \$ **2.0016** per gallon. Where any of the following are included as pay items in the contract, they will be eligible for fuel price adjustment.

The pay items and the fuel factor used in calculating adjustments to be made will be as follows:

<b>Description</b>	<b>Units</b>	<b>Fuel Usage Factor Diesel</b>
Unclassified Excavation	Gal/CY	0.29
Borrow Excavation	Gal/CY	0.29
Class IV Subgrade Stabilization	Gal/Ton	0.55
Aggregate Base Course	Gal/Ton	0.55
Sub-Ballast	Gal/Ton	0.55
Asphalt Concrete Base Course, Type _____	Gal/Ton	2.90
Asphalt Concrete Intermediate Course, Type _____	Gal/Ton	2.90
Asphalt Concrete Surface Course, Type _____	Gal/Ton	2.90
Open-Graded Asphalt Friction Course	Gal/Ton	2.90
Permeable Asphalt Drainage Course, Type _____	Gal/Ton	2.90
Sand Asphalt Surface Course, Type _____	Gal/Ton	2.90
Aggregate for Cement Treated Base Course	Gal/Ton	0.55
Portland Cement for Cement Treated Base Course	Gal/Ton	0.55

__" Portland Cement Concrete Pavement	Gal/SY	0.245
Concrete Shoulders Adjacent to __" Pavement	Gal/SY	0.245

**SCHEDULE OF ESTIMATED COMPLETION PROGRESS:**

(7-15-08) (Rev. 5-16-17)

108-2

SP1 G58

The Contractor's attention is directed to the Standard Special Provision entitled *Availability of Funds Termination of Contracts* included elsewhere in this proposal. The Department of Transportation's schedule of estimated completion progress for this project as required by that Standard Special Provision is as follows:

	<b><u>Fiscal Year</u></b>	<b><u>Progress (% of Dollar Value)</u></b>
2018	(7/01/17 - 6/30/18)	<b>26%</b> of Total Amount Bid
2019	(7/01/18 - 6/30/19)	<b>65%</b> of Total Amount Bid
2020	(7/01/19 - 6/30/20)	<b>9%</b> of Total Amount Bid

The Contractor shall also furnish his own progress schedule in accordance with Article 108-2 of the *2018 Standard Specifications*. Any acceleration of the progress as shown by the Contractor's progress schedule over the progress as shown above shall be subject to the approval of the Engineer.

**DISADVANTAGED BUSINESS ENTERPRISE:**

(10-16-07)(Rev. 1-17-17)

102-15(J)

SP1 G61

**Description**

The purpose of this Special Provision is to carry out the U.S. Department of Transportation's policy of ensuring nondiscrimination in the award and administration of contracts financed in whole or in part with Federal funds. This provision is guided by 49 CFR Part 26.

**Definitions**

*Additional DBE Subcontractors* - Any DBE submitted at the time of bid that will not be used to meet the DBE goal. No submittal of a Letter of Intent is required.

*Committed DBE Subcontractor* - Any DBE submitted at the time of bid that is being used to meet the DBE goal by submission of a Letter of Intent. Or any DBE used as a replacement for a previously committed DBE firm.

*Contract Goal Requirement* - The approved DBE participation at time of award, but not greater than the advertised contract goal.

*DBE Goal* - A portion of the total contract, expressed as a percentage, that is to be performed by committed DBE subcontractor(s).

*Disadvantaged Business Enterprise (DBE)* - A firm certified as a Disadvantaged Business Enterprise through the North Carolina Unified Certification Program.



*Goal Confirmation Letter* - Written documentation from the Department to the bidder confirming the Contractor's approved, committed DBE participation along with a listing of the committed DBE firms.

*Manufacturer* - A firm that operates or maintains a factory or establishment that produces on the premises, the materials or supplies obtained by the Contractor.

*Regular Dealer* - A firm that owns, operates, or maintains a store, warehouse, or other establishment in which the materials or supplies required for the performance of the contract are bought, kept in stock, and regularly sold to the public in the usual course of business. A regular dealer engages in, as its principal business and in its own name, the purchase and sale or lease of the products in question. A regular dealer in such bulk items as steel, cement, gravel, stone, and petroleum products need not keep such products in stock, if it owns and operates distribution equipment for the products. Brokers and packagers are not regarded as manufacturers or regular dealers within the meaning of this section.

*North Carolina Unified Certification Program (NCUCP)* - A program that provides comprehensive services and information to applicants for DBE certification, such that an applicant is required to apply only once for a DBE certification that will be honored by all recipients of USDOT funds in the state and not limited to the Department of Transportation only. The Certification Program is in accordance with 49 CFR Part 26.

*United States Department of Transportation (USDOT)* - Federal agency responsible for issuing regulations (49 CFR Part 26) and official guidance for the DBE program.

### **Forms and Websites Referenced in this Provision**

*DBE Payment Tracking System* - On-line system in which the Contractor enters the payments made to DBE subcontractors who have performed work on the project.  
<https://apps.dot.state.nc.us/Vendor/PaymentTracking/>

*DBE-IS Subcontractor Payment Information* - Form for reporting the payments made to all DBE firms working on the project. This form is for paper bid projects only.  
<https://connect.ncdot.gov/business/Turnpike/Documents/Form%20DBE-IS%20Subcontractor%20Payment%20Information.pdf>

*RF-1 DBE Replacement Request Form* - Form for replacing a committed DBE.  
<http://connect.ncdot.gov/projects/construction/Construction%20Forms/DBE%20MBE%20WBE%20Replacement%20Request%20Form.pdf>

*SAF Subcontract Approval Form* - Form required for approval to sublet the contract.  
<http://connect.ncdot.gov/projects/construction/Construction%20Forms/Subcontract%20Approval%20Form%20Rev.%202012.zip>

*JC-1 Joint Check Notification Form* - Form and procedures for joint check notification. The form acts as a written joint check agreement among the parties providing full and prompt disclosure of the expected use of joint checks.

<http://connect.ncdot.gov/projects/construction/Construction%20Forms/Joint%20Check%20Notification%20Form.pdf>

*Letter of Intent* - Form signed by the Contractor and the DBE subcontractor, manufacturer or regular dealer that affirms that a portion of said contract is going to be performed by the signed DBE for the amount listed at the time of bid.

<http://connect.ncdot.gov/letting/LetCentral/Letter%20of%20Intent%20to%20Perform%20as%20a%20Subcontractor.pdf>

*Listing of DBE Subcontractors Form* - Form for entering DBE subcontractors on a project that will meet this DBE goal. This form is for paper bids only.

[http://connect.ncdot.gov/municipalities/Bid%20Proposals%20for%20LGA%20Content/08%20DBE%20Subcontractors%20\(Federal\).docx](http://connect.ncdot.gov/municipalities/Bid%20Proposals%20for%20LGA%20Content/08%20DBE%20Subcontractors%20(Federal).docx)

*Subcontractor Quote Comparison Sheet* - Spreadsheet for showing all subcontractor quotes in the work areas where DBEs quoted on the project. This sheet is submitted with good faith effort packages.

<http://connect.ncdot.gov/business/SmallBusiness/Documents/DBE%20Subcontractor%20Quote%20Comparison%20Example.xls>

## **DBE Goal**

The following DBE goal for participation by Disadvantaged Business Enterprises is established for this contract:

Disadvantaged Business Enterprises **9.0** %

- (A) *If the DBE goal is more than zero*, the Contractor shall exercise all necessary and reasonable steps to ensure that DBEs participate in at least the percent of the contract as set forth above as the DBE goal.
- (B) *If the DBE goal is zero*, the Contractor shall make an effort to recruit and use DBEs during the performance of the contract. Any DBE participation obtained shall be reported to the Department.

## **Directory of Transportation Firms (Directory)**

Real-time information is available about firms doing business with the Department and firms that are certified through NCUCP in the Directory of Transportation Firms. Only firms identified in the Directory as DBE certified shall be used to meet the DBE goal. The Directory can be found at the following link. [https:// www.ebs.nc.gov/VendorDirectory/default.html](https://www.ebs.nc.gov/VendorDirectory/default.html)

The listing of an individual firm in the directory shall not be construed as an endorsement of the firm's capability to perform certain work.

### Listing of DBE Subcontractors

At the time of bid, bidders shall submit all DBE participation that they anticipate to use during the life of the contract. Only those identified to meet the DBE goal will be considered committed, even though the listing shall include both committed DBE subcontractors and additional DBE subcontractors. Additional DBE subcontractor participation submitted at the time of bid will be used toward the Department's overall race-neutral goal. Only those firms with current DBE certification at the time of bid opening will be acceptable for listing in the bidder's submittal of DBE participation. The Contractor shall indicate the following required information:

(A) Electronic Bids

Bidders shall submit a listing of DBE participation in the appropriate section of Expedite, the bidding software of Bid Express<sup>®</sup>.

- (1) Submit the names and addresses of DBE firms identified to participate in the contract. If the bidder uses the updated listing of DBE firms shown in Expedite, the bidder may use the dropdown menu to access the name and address of the DBE firm.
- (2) Submit the contract line numbers of work to be performed by each DBE firm. When no figures or firms are entered, the bidder will be considered to have no DBE participation.
- (3) The bidder shall be responsible for ensuring that the DBE is certified at the time of bid by checking the Directory of Transportation Firms. If the firm is not certified at the time of the bid-letting, that DBE's participation will not count towards achieving the DBE goal.

(B) Paper Bids

- (1) *If the DBE goal is more than zero,*
  - (a) Bidders, at the time the bid proposal is submitted, shall submit a listing of DBE participation, including the names and addresses on *Listing of DBE Subcontractors* contained elsewhere in the contract documents in order for the bid to be considered responsive. Bidders shall indicate the total dollar value of the DBE participation for the contract.
  - (b) If bidders have no DBE participation, they shall indicate this on the *Listing of DBE Subcontractors* by entering the word "None" or the number "0." This form shall be completed in its entirety. **Blank forms will not be deemed to represent zero participation.** Bids submitted that do not have DBE participation indicated on the appropriate form will not be read publicly during the opening of bids. The Department will not consider these bids for award and the proposal will be rejected.

- (c) The bidder shall be responsible for ensuring that the DBE is certified at the time of bid by checking the Directory of Transportation Firms. If the firm is not certified at the time of the bid-letting, that DBE's participation will not count towards achieving the corresponding goal.
- (2) *If the DBE goal is zero*, entries on the *Listing of DBE Subcontractors* are not required for the zero goal, however any DBE participation that is achieved during the project shall be reported in accordance with requirements contained elsewhere in the special provision.

### **DBE Prime Contractor**

When a certified DBE firm bids on a contract that contains a DBE goal, the DBE firm is responsible for meeting the goal or making good faith efforts to meet the goal, just like any other bidder. In most cases, a DBE bidder on a contract will meet the DBE goal by virtue of the work it performs on the contract with its own forces. However, all the work that is performed by the DBE bidder and any other DBE subcontractors will count toward the DBE goal. The DBE bidder shall list itself along with any DBE subcontractors, if any, in order to receive credit toward the DBE goal.

For example, if the DBE goal is 45% and the DBE bidder will only perform 40% of the contract work, the prime will list itself at 40%, and the additional 5% shall be obtained through additional DBE participation with DBE subcontractors or documented through a good faith effort.

DBE prime contractors shall also follow Sections A and B listed under *Listing of DBE Subcontractor* just as a non-DBE bidder would.

### **Written Documentation – Letter of Intent**

The bidder shall submit written documentation for each DBE that will be used to meet the DBE goal of the contract, indicating the bidder's commitment to use the DBE in the contract. This documentation shall be submitted on the Department's form titled *Letter of Intent*.

The documentation shall be received in the office of the State Contractor Utilization Engineer or at DBE@ncdot.gov no later than 10:00 a.m. of the sixth calendar day following opening of bids, unless the sixth day falls on an official state holiday. In that situation, it is due in the office of the State Contractor Utilization Engineer no later than 10:00 a.m. on the next official state business day.

If the bidder fails to submit the Letter of Intent from each committed DBE to be used toward the DBE goal, or if the form is incomplete (i.e. both signatures are not present), the DBE participation will not count toward meeting the DBE goal. If the lack of this participation drops the commitment below the DBE goal, the Contractor shall submit evidence of good faith efforts, completed in its entirety, to the State Contractor Utilization Engineer or DBE@ncdot.gov no later than 10:00 a.m. on the eighth calendar day following opening of bids, unless the eighth day falls on an official state holiday. In that situation, it is due in the office of the State Contractor Utilization Engineer no later than 10:00 a.m. on the next official state business day.

**Submission of Good Faith Effort**

If the bidder fails to meet or exceed the DBE goal, the apparent lowest responsive bidder shall submit to the Department documentation of adequate good faith efforts made to reach the DBE goal.

A hard copy and an electronic copy of this information shall be received in the office of the State Contractor Utilization Engineer or at DBE@ncdot.gov no later than 10:00 a.m. on the sixth calendar day following opening of bids unless the sixth day falls on an official state holiday. In that situation, it is due in the office of the State Contractor Utilization Engineer no later than 10:00 a.m. on the next official state business day. If the contractor cannot send the information electronically, then one complete set and 9 copies of this information shall be received under the same time constraints above.

Note: Where the information submitted includes repetitious solicitation letters, it will be acceptable to submit a representative letter along with a distribution list of the firms that were solicited. Documentation of DBE quotations shall be a part of the good faith effort submittal. This documentation may include written subcontractor quotations, telephone log notations of verbal quotations, or other types of quotation documentation.

**Consideration of Good Faith Effort for Projects with DBE Goals More Than Zero**

Adequate good faith efforts mean that the bidder took all necessary and reasonable steps to achieve the goal which, by their scope, intensity, and appropriateness, could reasonably be expected to obtain sufficient DBE participation. Adequate good faith efforts also mean that the bidder actively and aggressively sought DBE participation. Mere *pro forma* efforts are not considered good faith efforts.

The Department will consider the quality, quantity, and intensity of the different kinds of efforts a bidder has made. Listed below are examples of the types of actions a bidder will take in making a good faith effort to meet the goal and are not intended to be exclusive or exhaustive, nor is it intended to be a mandatory checklist.

- (A) Soliciting through all reasonable and available means (e.g. attendance at pre-bid meetings, advertising, written notices, use of verifiable electronic means through the use of the NCDOT Directory of Transportation Firms) the interest of all certified DBEs who have the capability to perform the work of the contract. The bidder must solicit this interest within at least 10 days prior to bid opening to allow the DBEs to respond to the solicitation. Solicitation shall provide the opportunity to DBEs within the Division and surrounding Divisions where the project is located. The bidder must determine with certainty if the DBEs are interested by taking appropriate steps to follow up initial solicitations.

- (B) Selecting portions of the work to be performed by DBEs in order to increase the likelihood that the DBE goals will be achieved.
  - (1) Where appropriate, break out contract work items into economically feasible units to facilitate DBE participation, even when the prime contractor might otherwise prefer to perform these work items with its own forces.
  - (2) Negotiate with subcontractors to assume part of the responsibility to meet the contract DBE goal when the work to be sublet includes potential for DBE participation (2<sup>nd</sup> and 3<sup>rd</sup> tier subcontractors).
- (C) Providing interested DBEs with adequate information about the plans, specifications, and requirements of the contract in a timely manner to assist them in responding to a solicitation.
- (D)
  - (1) Negotiating in good faith with interested DBEs. It is the bidder's responsibility to make a portion of the work available to DBE subcontractors and suppliers and to select those portions of the work or material needs consistent with the available DBE subcontractors and suppliers, so as to facilitate DBE participation. Evidence of such negotiation includes the names, addresses, and telephone numbers of DBEs that were considered; a description of the information provided regarding the plans and specifications for the work selected for subcontracting; and evidence as to why additional agreements could not be reached for DBEs to perform the work.
  - (2) A bidder using good business judgment would consider a number of factors in negotiating with subcontractors, including DBE subcontractors, and would take a firm's price and capabilities as well as contract goals into consideration. However, the fact that there may be some additional costs involved in finding and using DBEs is not in itself sufficient reason for a bidder's failure to meet the contract DBE goal, as long as such costs are reasonable. Also, the ability or desire of a prime contractor to perform the work of a contract with its own organization does not relieve the bidder of the responsibility to make good faith efforts. Bidding contractors are not, however, required to accept higher quotes from DBEs if the price difference is excessive or unreasonable.
- (E) Not rejecting DBEs as being unqualified without sound reasons based on a thorough investigation of their capabilities. The bidder's standing within its industry, membership in specific groups, organizations, or associates and political or social affiliations (for example, union vs. non-union employee status) are not legitimate causes for the rejection or non-solicitation of bids in the bidder's efforts to meet the project goal.
- (F) Making efforts to assist interested DBEs in obtaining bonding, lines of credit, or insurance as required by the recipient or bidder.
- (G) Making efforts to assist interested DBEs in obtaining necessary equipment, supplies, materials, or related assistance or services.

- (H) Effectively using the services of available minority/women community organizations; minority/women contractors' groups; Federal, State, and local minority/women business assistance offices; and other organizations as allowed on a case-by-case basis to provide assistance in the recruitment and placement of DBEs. Contact within 7 days from the bid opening the Business Opportunity and Work Force Development Unit at DBE@ncdot.gov to give notification of the bidder's inability to get DBE quotes.
- (I) Any other evidence that the bidder submits which shows that the bidder has made reasonable good faith efforts to meet the DBE goal.

In addition, the Department may take into account the following:

- (1) Whether the bidder's documentation reflects a clear and realistic plan for achieving the DBE goal.
- (2) The bidders' past performance in meeting the DBE goals.
- (3) The performance of other bidders in meeting the DBE goal. For example, when the apparent successful bidder fails to meet the DBE goal, but others meet it, you may reasonably raise the question of whether, with additional reasonable efforts the apparent successful bidder could have met the goal. If the apparent successful bidder fails to meet the DBE goal, but meets or exceeds the average DBE participation obtained by other bidders, the Department may view this, in conjunction with other factors, as evidence of the apparent successful bidder having made a good faith effort.

If the Department does not award the contract to the apparent lowest responsive bidder, the Department reserves the right to award the contract to the next lowest responsive bidder that can satisfy to the Department that the DBE goal can be met or that an adequate good faith effort has been made to meet the DBE goal.

### **Non-Good Faith Appeal**

The State Contractual Services Engineer will notify the contractor verbally and in writing of non-good faith. A contractor may appeal a determination of non-good faith made by the Goal Compliance Committee. If a contractor wishes to appeal the determination made by the Committee, they shall provide written notification to the State Contractual Services Engineer or at DBE@ncdot.gov. The appeal shall be made within 2 business days of notification of the determination of non-good faith.

### **Counting DBE Participation Toward Meeting DBE Goal**

- (A) Participation

The total dollar value of the participation by a committed DBE will be counted toward the contract goal requirement. The total dollar value of participation by a committed DBE will be based upon the value of work actually performed by the DBE and the actual payments to DBE firms by the Contractor.

## (B) Joint Checks

Prior notification of joint check use shall be required when counting DBE participation for services or purchases that involves the use of a joint check. Notification shall be through submission of Form JC-1 (*Joint Check Notification Form*) and the use of joint checks shall be in accordance with the Department's Joint Check Procedures.

## (C) Subcontracts (Non-Trucking)

A DBE may enter into subcontracts. Work that a DBE subcontracts to another DBE firm may be counted toward the contract goal requirement. Work that a DBE subcontracts to a non-DBE firm does not count toward the contract goal requirement. If a DBE contractor or subcontractor subcontracts a significantly greater portion of the work of the contract than would be expected on the basis of standard industry practices, it shall be presumed that the DBE is not performing a commercially useful function. The DBE may present evidence to rebut this presumption to the Department. The Department's decision on the rebuttal of this presumption is subject to review by the Federal Highway Administration but is not administratively appealable to USDOT.

## (D) Joint Venture

When a DBE performs as a participant in a joint venture, the Contractor may count toward its contract goal requirement a portion of the total value of participation with the DBE in the joint venture, that portion of the total dollar value being a distinct clearly defined portion of work that the DBE performs with its forces.

## (E) Suppliers

A contractor may count toward its DBE requirement 60 percent of its expenditures for materials and supplies required to complete the contract and obtained from a DBE regular dealer and 100 percent of such expenditures from a DBE manufacturer.

## (F) Manufacturers and Regular Dealers

A contractor may count toward its DBE requirement the following expenditures to DBE firms that are not manufacturers or regular dealers:

- (1) The fees or commissions charged by a DBE firm for providing a *bona fide* service, such as professional, technical, consultant, or managerial services, or for providing bonds or insurance specifically required for the performance of a DOT-assisted contract, provided the fees or commissions are determined to be reasonable and not excessive as compared with fees and commissions customarily allowed for similar services.
- (2) With respect to materials or supplies purchased from a DBE, which is neither a manufacturer nor a regular dealer, count the entire amount of fees or commissions charged for assistance in the procurement of the materials and supplies, or fees or



transportation charges for the delivery of materials or supplies required on a job site (but not the cost of the materials and supplies themselves), provided the fees are determined to be reasonable and not excessive as compared with fees customarily allowed for similar services.

### **Commercially Useful Function**

#### **(A) DBE Utilization**

The Contractor may count toward its contract goal requirement only expenditures to DBEs that perform a commercially useful function in the work of a contract. A DBE performs a commercially useful function when it is responsible for execution of the work of the contract and is carrying out its responsibilities by actually performing, managing, and supervising the work involved. To perform a commercially useful function, the DBE shall also be responsible with respect to materials and supplies used on the contract, for negotiating price, determining quality and quantity, ordering the material and installing (where applicable) and paying for the material itself. To determine whether a DBE is performing a commercially useful function, the Department will evaluate the amount of work subcontracted, industry practices, whether the amount the firm is to be paid under the contract is commensurate with the work it is actually performing and the DBE credit claimed for its performance of the work, and any other relevant factors.

#### **(B) DBE Utilization in Trucking**

The following factors will be used to determine if a DBE trucking firm is performing a commercially useful function:

- (1) The DBE shall be responsible for the management and supervision of the entire trucking operation for which it is responsible on a particular contract, and there shall not be a contrived arrangement for the purpose of meeting DBE goals.
- (2) The DBE shall itself own and operate at least one fully licensed, insured, and operational truck used on the contract.
- (3) The DBE receives credit for the total value of the transportation services it provides on the contract using trucks it owns, insures, and operates using drivers it employs.
- (4) The DBE may subcontract the work to another DBE firm, including an owner-operator who is certified as a DBE. The DBE who subcontracts work to another DBE receives credit for the total value of the transportation services the subcontracted DBE provides on the contract.
- (5) The DBE may also subcontract the work to a non-DBE firm, including from an owner-operator. The DBE who subcontracts the work to a non-DBE is entitled to credit for the total value of transportation services provided by the non-DBE subcontractor not to exceed the value of transportation services provided by DBE-owned trucks on the contract. Additional participation by non-DBE subcontractors receives credit only for the fee or commission it receives as a result

of the subcontract arrangement. The value of services performed under subcontract agreements between the DBE and the Contractor will not count towards the DBE contract requirement.

- (6) A DBE may lease truck(s) from an established equipment leasing business open to the general public. The lease must indicate that the DBE has exclusive use of and control over the truck. This requirement does not preclude the leased truck from working for others during the term of the lease with the consent of the DBE, so long as the lease gives the DBE absolute priority for use of the leased truck. This type of lease may count toward the DBE's credit as long as the driver is under the DBE's payroll.
- (7) Subcontracted/leased trucks shall display clearly on the dashboard the name of the DBE that they are subcontracted/leased to and their own company name if it is not identified on the truck itself. Magnetic door signs are not permitted.

### **DBE Replacement**

When a Contractor has relied on a commitment to a DBE firm (or an approved substitute DBE firm) to meet all or part of a contract goal requirement, the contractor shall not terminate the DBE for convenience. This includes, but is not limited to, instances in which the Contractor seeks to perform the work of the terminated subcontractor with another DBE subcontractor, a non-DBE subcontractor, or with the Contractor's own forces or those of an affiliate. A DBE may only be terminated after receiving the Engineer's written approval based upon a finding of good cause for the termination. The prime contractor must give the DBE firm five (5) calendar days to respond to the prime contractor's notice of termination and advise the prime contractor and the Department of the reasons, if any, why the firm objects to the proposed termination of its subcontract and why the Department should not approve the action.

All requests for replacement of a committed DBE firm shall be submitted to the Engineer for approval on Form RF-1 (*DBE Replacement Request*). If the Contractor fails to follow this procedure, the Contractor may be disqualified from further bidding for a period of up to 6 months.

The Contractor shall comply with the following for replacement of a committed DBE:

#### **(A) Performance Related Replacement**

When a committed DBE is terminated for good cause as stated above, an additional DBE that was submitted at the time of bid may be used to fulfill the DBE commitment. A good faith effort will only be required for removing a committed DBE if there were no additional DBEs submitted at the time of bid to cover the same amount of work as the DBE that was terminated.

If a replacement DBE is not found that can perform at least the same amount of work as the terminated DBE, the Contractor shall submit a good faith effort documenting the steps taken. Such documentation shall include, but not be limited to, the following:

- (1) Copies of written notification to DBEs that their interest is solicited in contracting the work defaulted by the previous DBE or in subcontracting other items of work in the contract.
  - (2) Efforts to negotiate with DBEs for specific subbids including, at a minimum:
    - (a) The names, addresses, and telephone numbers of DBEs who were contacted.
    - (b) A description of the information provided to DBEs regarding the plans and specifications for portions of the work to be performed.
  - (3) A list of reasons why DBE quotes were not accepted.
  - (4) Efforts made to assist the DBEs contacted, if needed, in obtaining bonding or insurance required by the Contractor.
- (B) Decertification Replacement
- (1) When a committed DBE is decertified by the Department after the SAF (*Subcontract Approval Form*) has been received by the Department, the Department will not require the Contractor to solicit replacement DBE participation equal to the remaining work to be performed by the decertified firm. The participation equal to the remaining work performed by the decertified firm will count toward the contract goal requirement.
  - (2) When a committed DBE is decertified prior to the Department receiving the SAF (*Subcontract Approval Form*) for the named DBE firm, the Contractor shall take all necessary and reasonable steps to replace the DBE subcontractor with another DBE subcontractor to perform at least the same amount of work to meet the DBE goal requirement. If a DBE firm is not found to do the same amount of work, a good faith effort must be submitted to NCDOT (see A herein for required documentation).

### **Changes in the Work**

When the Engineer makes changes that result in the reduction or elimination of work to be performed by a committed DBE, the Contractor will not be required to seek additional participation. When the Engineer makes changes that result in additional work to be performed by a DBE based upon the Contractor's commitment, the DBE shall participate in additional work to the same extent as the DBE participated in the original contract work.

When the Engineer makes changes that result in extra work, which has more than a minimal impact on the contract amount, the Contractor shall seek additional participation by DBEs unless otherwise approved by the Engineer.

When the Engineer makes changes that result in an alteration of plans or details of construction, and a portion or all of the work had been expected to be performed by a committed DBE, the Contractor shall seek participation by DBEs unless otherwise approved by the Engineer.

When the Contractor requests changes in the work that result in the reduction or elimination of work that the Contractor committed to be performed by a DBE, the Contractor shall seek additional participation by DBEs equal to the reduced DBE participation caused by the changes.

### **Reports and Documentation**

A SAF (*Subcontract Approval Form*) shall be submitted for all work which is to be performed by a DBE subcontractor. The Department reserves the right to require copies of actual subcontract agreements involving DBE subcontractors.

When using transportation services to meet the contract commitment, the Contractor shall submit a proposed trucking plan in addition to the SAF. The plan shall be submitted prior to beginning construction on the project. The plan shall include the names of all trucking firms proposed for use, their certification type(s), the number of trucks owned by the firm, as well as the individual truck identification numbers, and the line item(s) being performed.

Within 30 calendar days of entering into an agreement with a DBE for materials, supplies or services, not otherwise documented by the SAF as specified above, the Contractor shall furnish the Engineer a copy of the agreement. The documentation shall also indicate the percentage (60% or 100%) of expenditures claimed for DBE credit.

### **Reporting Disadvantaged Business Enterprise Participation**

The Contractor shall provide the Engineer with an accounting of payments made to all DBE firms, including material suppliers and contractors at all levels (prime, subcontractor, or second tier subcontractor). This accounting shall be furnished to the Engineer for any given month by the end of the following month. Failure to submit this information accordingly may result in the following action:

- (A) Withholding of money due in the next partial pay estimate; or
- (B) Removal of an approved contractor from the prequalified bidders' list or the removal of other entities from the approved subcontractors list.

While each contractor (prime, subcontractor, 2nd tier subcontractor) is responsible for accurate accounting of payments to DBEs, it shall be the prime contractor's responsibility to report all monthly and final payment information in the correct reporting manner.

Failure on the part of the Contractor to submit the required information in the time frame specified may result in the disqualification of that contractor and any affiliate companies from further bidding until the required information is submitted.

Failure on the part of any subcontractor to submit the required information in the time frame specified may result in the disqualification of that contractor and any affiliate companies from being approved for work on future DOT projects until the required information is submitted.

Contractors reporting transportation services provided by non-DBE lessees shall evaluate the value of services provided during the month of the reporting period only.

At any time, the Engineer can request written verification of subcontractor payments.

The Contractor shall report the accounting of payments through the Department's DBE Payment Tracking System.

### **Failure to Meet Contract Requirements**

Failure to meet contract requirements in accordance with Subarticle 102-15(J) of the *2018 Standard Specifications* may be cause to disqualify the Contractor.

### **CERTIFICATION FOR FEDERAL-AID CONTRACTS:**

(3-21-90)

SP1 G85

The prospective participant certifies, by signing and submitting this bid or proposal, to the best of his or her knowledge and belief, that:

- (A) No Federal appropriated funds have been paid or will be paid, by or on behalf of the undersigned, to any person for influencing or attempting to influence an officer or employee of any Federal agency, a Member of Congress, an officer or employee of Congress, or an employee of a Member of Congress in connection with the awarding of any Federal contract, the making of any Federal grant, the making of any Federal loan, the entering into of any cooperative agreement, and the extension, continuation, renewal, amendment, or modification of any Federal contract, grant, loan, or cooperative agreement.
- (B) If any funds other than Federal appropriated funds have been paid or will be paid to any person for influencing or attempting to influence an officer or employee of any Federal agency, a Member of Congress, an officer or employee of Congress, or an employee of a Member of Congress in connection with this Federal contract, grant, loan, or cooperative agreement, the undersigned shall complete and submit Standard Form-LLL, *Disclosure Form to Report Lobbying*, in accordance with its instructions.

This certification is a material representation of fact upon which reliance was placed when this transaction was made or entered into. Submission of this certification is a prerequisite for making or entering into this transaction imposed by *Section 1352, Title 31, U.S. Code*. Any person who fails to file the required certification shall be subject to a civil penalty of not less than \$10,000 and not more than \$100,000 for each such failure.

The prospective participant also agrees by submitting his or her bid or proposal that he or she shall require that the language of this certification be included in all lower tier subcontracts, which exceed \$100,000 and that all such subrecipients shall certify and disclose accordingly.

**U.S. DEPARTMENT OF TRANSPORTATION HOTLINE:**

(11-22-94)

108-5

SP1 G100

To report bid rigging activities call: **1-800-424-9071**

The U.S. Department of Transportation (DOT) operates the above toll-free hotline Monday through Friday, 8:00 a.m. to 5:00 p.m. eastern time. Anyone with knowledge of possible bid rigging, bidder collusion, or other fraudulent activities should use the hotline to report such activities.

The hotline is part of the DOT's continuing effort to identify and investigate highway construction contract fraud and abuse is operated under the direction of the DOT Inspector General. All information will be treated confidentially and caller anonymity will be respected.

**CARGO PREFERENCE ACT:**

(2-16-16)

Privately owned United States-flag commercial vessels transporting cargoes are subject to the Cargo Preference Act (CPA) of 1954 requirements and regulations found in 46 CFR 381.7. Contractors are directed to clause (b) of 46 CFR 381.7 as follows:

(b) Contractor and Subcontractor Clauses. "Use of United States-flag vessels: The contractor agrees-

" (1) To utilize privately owned United States-flag commercial vessels to ship at least 50 percent of the gross tonnage (computed separately for dry bulk carriers, dry cargo liners, and tankers) involved, whenever shipping any equipment, material, or commodities pursuant to this contract, to the extent such vessels are available at fair and reasonable rates for United States-flag commercial vessels.

(2) To furnish within 20 days following the date of loading for shipments originating within the United States or within 30 working days following the date of loading for shipments originating outside the United States a legible copy of a rated, 'on-board' commercial ocean bill-of-lading in English for each shipment of cargo described in paragraph (b) (1) of this section to both the Contracting Officer (through the prime contractor in the case of subcontractor bills-of-lading) and to the Division of National Cargo, Office of Market Development, Maritime Administration, Washington, DC 20590.

(3) To insert the substance of the provisions of this clause in all subcontracts issued pursuant to this contract."

**MAINTENANCE OF THE PROJECT:**

(11-20-07) (Rev. 1-17-12)

104-10

SP1 G125

Revise the *2018 Standard Specifications* as follows:

**Page 1-39, Article 104-10 Maintenance of the Project, line 25**, add the following after the first sentence of the first paragraph:

All guardrail/guiderail within the project limits shall be included in this maintenance.

**Page 1-39, Article 104-10 Maintenance of the Project, line 30**, add the following as the last sentence of the first paragraph:

The Contractor shall perform weekly inspections of guardrail and guiderail and shall report damages to the Engineer on the same day of the weekly inspection. *Where damaged guardrail or guiderail is repaired or replaced as a result of maintaining the project in accordance with this article, such repair or replacement shall be performed within 7 consecutive calendar days of such inspection report.*

**Page 1-39, Article 104-10 Maintenance of the Project, lines 42-44**, replace the last sentence of the last paragraph with the following:

The Contractor will not be directly compensated for any maintenance operations necessary, except for maintenance of guardrail/guiderail, as this work will be considered incidental to the work covered by the various contract items. The provisions of Article 104-7, Extra Work, and Article 104-8, Compensation and Record Keeping will apply to authorized maintenance of guardrail/guiderail. Performance of weekly inspections of guardrail/guiderail, and the damage reports required as described above, will be considered to be an incidental part of the work being paid for by the various contract items.

#### **EROSION AND SEDIMENT CONTROL/STORMWATER CERTIFICATION:**

(1-16-07) (Rev 11-22-16)

105-16, 225-2, 16

SP1 G180

#### **General**

Schedule and conduct construction activities in a manner that will minimize soil erosion and the resulting sedimentation and turbidity of surface waters. Comply with the requirements herein regardless of whether or not a National Pollution discharge Elimination System (NPDES) permit for the work is required.

Establish a chain of responsibility for operations and subcontractors' operations to ensure that the *Erosion and Sediment Control/Stormwater Pollution Prevention Plan* is implemented and maintained over the life of the contract.

- (A) *Certified Supervisor* - Provide a certified Erosion and Sediment Control/Stormwater Supervisor to manage the Contractor and subcontractor operations, insure compliance with Federal, State and Local ordinances and regulations, and manage the Quality Control Program.
- (B) *Certified Foreman* - Provide a certified, trained foreman for each construction operation that increases the potential for soil erosion or the possible sedimentation and turbidity of surface waters.
- (C) *Certified Installer* - Provide a certified installer to install or direct the installation for erosion or sediment/stormwater control practices.
- (D) *Certified Designer* - Provide a certified designer for the design of the erosion and sediment control/stormwater component of reclamation plans and, if applicable, for the design of the project erosion and sediment control/stormwater plan.

## Roles and Responsibilities

- (A) *Certified Erosion and Sediment Control/Stormwater Supervisor* - The Certified Supervisor shall be Level II and responsible for ensuring the erosion and sediment control/stormwater plan is adequately implemented and maintained on the project and for conducting the quality control program. The Certified Supervisor shall be on the project within 24 hours notice from initial exposure of an erodible surface to the project's final acceptance. Perform the following duties:
- (1) **Manage Operations** - Coordinate and schedule the work of subcontractors so that erosion and sediment control/stormwater measures are fully executed for each operation and in a timely manner over the duration of the contract.
    - (a) Oversee the work of subcontractors so that appropriate erosion and sediment control/stormwater preventive measures are conformed to at each stage of the work.
    - (b) Prepare the required National Pollutant Discharge Elimination System (NPDES) Inspection Record and submit to the Engineer.
    - (c) Attend all weekly or monthly construction meetings to discuss the findings of the NPDES inspection and other related issues.
    - (d) Implement the erosion and sediment control/stormwater site plans requested.
    - (e) Provide any needed erosion and sediment control/stormwater practices for the Contractor's temporary work not shown on the plans, such as, but not limited to work platforms, temporary construction, pumping operations, plant and storage yards, and cofferdams.
    - (f) Acquire applicable permits and comply with requirements for borrow pits, dewatering, and any temporary work conducted by the Contractor in jurisdictional areas.
    - (g) Conduct all erosion and sediment control/stormwater work in a timely and workmanlike manner.
    - (h) Fully perform and install erosion and sediment control/stormwater work prior to any suspension of the work.
    - (i) Coordinate with Department, Federal, State and Local Regulatory agencies on resolution of erosion and sediment control/stormwater issues due to the Contractor's operations.
    - (j) Ensure that proper cleanup occurs from vehicle tracking on paved surfaces or any location where sediment leaves the Right-of-Way.
    - (k) Have available a set of erosion and sediment control/stormwater plans that are initialed and include the installation date of Best Management Practices. These practices shall include temporary and permanent groundcover and be properly updated to reflect necessary plan and field changes for use and review by Department personnel as well as regulatory agencies.
  - (2) Requirements set forth under the NPDES Permit - The Department's NPDES Stormwater permit (NCS000250) outlines certain objectives and management measures pertaining to construction activities. The permit references *NCG010000*,



*General Permit to Discharge Stormwater* under the NPDES, and states that the Department shall incorporate the applicable requirements into its delegated Erosion and Sediment Control Program for construction activities disturbing one or more acres of land. The Department further incorporates these requirements on all contracted bridge and culvert work at jurisdictional waters, regardless of size. Some of the requirements are, but are not limited to:

- (a) Control project site waste to prevent contamination of surface or ground waters of the state, i.e. from equipment operation/maintenance, construction materials, concrete washout, chemicals, litter, fuels, lubricants, coolants, hydraulic fluids, any other petroleum products, and sanitary waste.
  - (b) Inspect erosion and sediment control/stormwater devices and stormwater discharge outfalls at least once every 7 calendar days and within 24 hours after a rainfall event of 0.5 inch that occurs within a 24 hour period. Additional monitoring may be required at the discretion of Division of Water Resources personnel if the receiving stream is 303(d) listed for turbidity and the project has had documented problems managing turbidity.
  - (c) Maintain an onsite rain gauge or use the Department's Multi-Sensor Precipitation Estimate website to maintain a daily record of rainfall amounts and dates.
  - (d) Maintain erosion and sediment control/stormwater inspection records for review by Department and Regulatory personnel upon request.
  - (e) Implement approved reclamation plans on all borrow pits, waste sites and staging areas.
  - (f) Maintain a log of turbidity test results as outlined in the Department's Procedure for Monitoring Borrow Pit Discharge.
  - (g) Provide secondary containment for bulk storage of liquid materials.
  - (h) Provide training for employees concerning general erosion and sediment control/stormwater awareness, the Department's NPDES Stormwater Permit NCS000250 requirements, and the applicable requirements of the *General Permit, NCG010000*.
  - (i) Report violations of the NPDES permit to the Engineer immediately who will notify the Division of Water Quality Regional Office within 24 hours of becoming aware of the violation.
- (3) Quality Control Program - Maintain a quality control program to control erosion, prevent sedimentation and follow provisions/conditions of permits. The quality control program shall:
- (a) Follow permit requirements related to the Contractor and subcontractors' construction activities.
  - (b) Ensure that all operators and subcontractors on site have the proper erosion and sediment control/stormwater certification.
  - (c) Notify the Engineer when the required certified erosion and sediment control/stormwater personnel are not available on the job site when needed.
  - (d) Conduct the inspections required by the NPDES permit.
  - (e) Take corrective actions in the proper timeframe as required by the NPDES permit for problem areas identified during the NPDES inspections.

- (f) Incorporate erosion control into the work in a timely manner and stabilize disturbed areas with mulch/seed or vegetative cover on a section-by-section basis.
  - (g) Use flocculants approved by state regulatory authorities where appropriate and where required for turbidity and sedimentation reduction.
  - (h) Ensure proper installation and maintenance of temporary erosion and sediment control devices.
  - (i) Remove temporary erosion or sediment control devices when they are no longer necessary as agreed upon by the Engineer.
  - (j) The Contractor's quality control and inspection procedures shall be subject to review by the Engineer. Maintain NPDES inspection records and make records available at all times for verification by the Engineer.
- (B) *Certified Foreman* - At least one Certified Foreman shall be onsite for each type of work listed herein during the respective construction activities to control erosion, prevent sedimentation and follow permit provisions:
- (1) Foreman in charge of grading activities
  - (2) Foreman in charge of bridge or culvert construction over jurisdictional areas
  - (3) Foreman in charge of utility activities

The Contractor may request to use the same person as the Level II Supervisor and Level II Foreman. This person shall be onsite whenever construction activities as described above are taking place. This request shall be approved by the Engineer prior to work beginning.

The Contractor may request to name a single Level II Foreman to oversee multiple construction activities on small bridge or culvert replacement projects. This request shall be approved by the Engineer prior to work beginning.

- (C) *Certified Installers* - Provide at least one onsite, Level I Certified Installer for each of the following erosion and sediment control/stormwater crew:
- (1) Seeding and Mulching
  - (2) Temporary Seeding
  - (3) Temporary Mulching
  - (4) Sodding
  - (5) Silt fence or other perimeter erosion/sediment control device installations
  - (6) Erosion control blanket installation
  - (7) Hydraulic tackifier installation
  - (8) Turbidity curtain installation
  - (9) Rock ditch check/sediment dam installation
  - (10) Ditch liner/matting installation
  - (11) Inlet protection
  - (12) Riprap placement
  - (13) Stormwater BMP installations (such as but not limited to level spreaders, retention/detention devices)
  - (14) Pipe installations within jurisdictional areas

If a Level I *Certified Installer* is not onsite, the Contractor may substitute a Level II Foreman for a Level I Installer, provided the Level II Foreman is not tasked to another crew requiring Level II Foreman oversight.

- (D) *Certified Designer* - Include the certification number of the Level III-B Certified Designer on the erosion and sediment control/stormwater component of all reclamation plans and if applicable, the certification number of the Level III-A Certified Designer on the design of the project erosion and sediment control/stormwater plan.

### **Preconstruction Meeting**

Furnish the names of the *Certified Erosion and Sediment Control/Stormwater Supervisor*, *Certified Foremen*, *Certified Installers* and *Certified Designer* and notify the Engineer of changes in certified personnel over the life of the contract within 2 days of change.

### **Ethical Responsibility**

Any company performing work for the North Carolina Department of Transportation has the ethical responsibility to fully disclose any reprimand or dismissal of an employee resulting from improper testing or falsification of records.

### **Revocation or Suspension of Certification**

Upon recommendation of the Chief Engineer to the certification entity, certification for *Supervisor*, *Certified Foremen*, *Certified Installers* and *Certified Designer* may be revoked or suspended with the issuance of an *Immediate Corrective Action (ICA)*, *Notice of Violation (NOV)*, or *Cease and Desist Order* for erosion and sediment control/stormwater related issues.

The Chief Engineer may recommend suspension or permanent revocation of certification due to the following:

- (A) Failure to adequately perform the duties as defined within this certification provision.
- (B) Issuance of an ICA, NOV, or Cease and Desist Order.
- (C) Failure to fully perform environmental commitments as detailed within the permit conditions and specifications.
- (D) Demonstration of erroneous documentation or reporting techniques.
- (E) Cheating or copying another candidate's work on an examination.
- (F) Intentional falsification of records.
- (G) Directing a subordinate under direct or indirect supervision to perform any of the above actions.
- (H) Dismissal from a company for any of the above reasons.
- (I) Suspension or revocation of one's certification by another entity.

Suspension or revocation of a certification will be sent by certified mail to the certificant and the Corporate Head of the company that employs the certificant.

A certificant has the right to appeal any adverse action which results in suspension or permanent revocation of certification by responding, in writing, to the Chief Engineer within 10 calendar days after receiving notice of the proposed adverse action.

Chief Engineer  
1536 Mail Service Center  
Raleigh, NC 27699-1536

Failure to appeal within 10 calendar days will result in the proposed adverse action becoming effective on the date specified on the certified notice. Failure to appeal within the time specified will result in a waiver of all future appeal rights regarding the adverse action taken. The certificant will not be allowed to perform duties associated with the certification during the appeal process.

The Chief Engineer will hear the appeal and make a decision within 7 days of hearing the appeal. Decision of the Chief Engineer will be final and will be made in writing to the certificant.

If a certification is temporarily suspended, the certificant shall pass any applicable written examination and any proficiency examination, at the conclusion of the specified suspension period, prior to having the certification reinstated.

### **Measurement and Payment**

*Certified Erosion and Sediment Control/Stormwater Supervisor, Certified Foremen, Certified Installers and Certified Designer* will be incidental to the project for which no direct compensation will be made.

### **PROCEDURE FOR MONITORING BORROW PIT DISCHARGE:**

(2-20-07) (Rev. 3-19-13)

105-16, 230, 801

SP1 G181

Water discharge from borrow pit sites shall not cause surface waters to exceed 50 NTUs (nephelometric turbidity unit) in streams not designated as trout waters and 10 NTUs in streams, lakes or reservoirs designated as trout waters. For lakes and reservoirs not designated as trout waters, the turbidity shall not exceed 25 NTUs. If the turbidity exceeds these levels due to natural background conditions, the existing turbidity level shall not be increased.

If during any operating day, the downstream water quality exceeds the standard, the Contractor shall do all of the following:

- (A) Either cease discharge or modify the discharge volume or turbidity levels to bring the downstream turbidity levels into compliance, or
- (B) Evaluate the upstream conditions to determine if the exceedance of the standard is due to natural background conditions. If the background turbidity measurements exceed the standard, operation of the pit and discharge can continue as long as the stream turbidity levels are not increased due to the discharge.
- (C) Measure and record the turbidity test results (time, date and sampler) at all defined sampling locations 30 minutes after startup and at a minimum, one additional sampling of all sampling locations during that 24-hour period in which the borrow pit is discharging.

- (D) Notify DWQ within 24 hours of any stream turbidity standard exceedances that are not brought into compliance.

During the Environmental Assessment required by Article 230-4 of the *2018 Standard Specifications*, the Contractor shall define the point at which the discharge enters into the State's surface waters and the appropriate sampling locations. Sampling locations shall include points upstream and downstream from the point at which the discharge enters these waters. Upstream sampling location shall be located so that it is not influenced by backwater conditions and represents natural background conditions. Downstream sampling location shall be located at the point where complete mixing of the discharge and receiving water has occurred.

The discharge shall be closely monitored when water from the dewatering activities is introduced into jurisdictional wetlands. Any time visible sedimentation (deposition of sediment) on the wetland surface is observed, the dewatering activity will be suspended until turbidity levels in the stilling basin can be reduced to a level where sediment deposition does not occur. Staining of wetland surfaces from suspended clay particles, occurring after evaporation or infiltration, does not constitute sedimentation. No activities shall occur in wetlands that adversely affect the functioning of a wetland. Visible sedimentation will be considered an indication of possible adverse impacts on wetland use.

The Engineer will perform independent turbidity tests on a random basis. These results will be maintained in a log within the project records. Records will include, at a minimum, turbidity test results, time, date and name of sampler. Should the Department's test results exceed those of the Contractor's test results, an immediate test shall be performed jointly with the results superseding the previous test results of both the Department and the Contractor.

The Contractor shall use the *NCDOT Turbidity Reduction Options for Borrow Pits Matrix*, available at [http://www.ncdot.gov/doh/operations/dp\\_chief\\_eng/roadside/fieldops/downloads/Files/TurbidityReductionOptionSheet.pdf](http://www.ncdot.gov/doh/operations/dp_chief_eng/roadside/fieldops/downloads/Files/TurbidityReductionOptionSheet.pdf) to plan, design, construct, and maintain BMPs to address water quality standards. Tier I Methods include stilling basins which are standard compensatory BMPs. Other Tier I methods are noncompensatory and shall be used when needed to meet the stream turbidity standards. Tier II Methods are also noncompensatory and are options that may be needed for protection of rare or unique resources or where special environmental conditions exist at the site which have led to additional requirements being placed in the DWQ's 401 Certifications and approval letters, Isolated Wetland Permits, Riparian Buffer Authorization or a DOT Reclamation Plan's Environmental Assessment for the specific site. Should the Contractor exhaust all Tier I Methods on a site exclusive of rare or unique resources or special environmental conditions, Tier II Methods may be required by regulators on a case by case basis per supplemental agreement.

The Contractor may use cation exchange capacity (CEC) values from proposed site borings to plan and develop the bid for the project. CEC values exceeding 15 milliequivalents per 100 grams of soil may indicate a high potential for turbidity and should be avoided when dewatering into surface water is proposed.

No additional compensation for monitoring borrow pit discharge will be paid.

**PROJECT SPECIAL PROVISIONS****ROADWAY****SHOULDER RECONSTRUCTION PER SHOULDER MILE:**

(1-18-00) (Rev. 8-21-12)

560

SPI R07AR

**Description**

This work consists of reconstructing each shoulder (including median shoulders as applicable) in accordance with Standard Drawing No. 560.01 and 560.02 of the *2018 Roadway Standard Drawings* except that the rate of slope and width will be as shown on typical section, or to the existing shoulder point, whichever is nearer, as long as the desired typical is achieved, and when completed, seeding and mulching. This work shall be performed immediately after the resurfacing operations are complete as directed by the Engineer.

**Materials**

The Contractor shall furnish all earth material necessary for the construction of the shoulders in accordance with Section 1019 of the *2018 Standard Specifications*. All soil is subject to test and acceptance or rejection by the Engineer.

The Contractor will have the option of using Aggregate Shoulder Borrow (ASB) which meets the following gradation.

<u>Sieve</u>	<u>Percent Passing</u>
1 1/2"	100
1/2"	55 - 95
#4	35 - 74

**Construction Methods**

Obtain material from within the project limits or approved borrow source. Prior to adding borrow material, the existing shoulder shall be scarified to provide the proper bond and shall be compacted to the satisfaction of the Engineer.

Any excess material generated by the shoulder reconstruction shall be disposed of by the Contractor in an approved disposal site.

**Measurement and Payment**

*Shoulder Reconstruction* will be measured and paid as the actual number of miles of shoulders that have been reconstructed. Measurement will be made along the surface of each shoulder to the nearest 0.01 of a mile. Such price will include disposing of any excess material in an approved disposal site, and for all labor, tools, equipment, and incidentals necessary to complete the work.

*Borrow Excavation* will be paid in accordance with Section 230 of the *2018 Standard Specifications* for earth material furnished by the Contractor. The requirements of Article 104-5 of the *2018 Standard Specifications* pertaining to revised contract prices for overrunning minor

items will not apply to the item of *Borrow Excavation*. If ASB is used for borrow, a unit weight of 140 pounds per cubic foot will be used to convert the weight of ASB to cubic yards.

Incidental Stone Base will be measured and paid as provided in Article 545-6 of the *2018 Standard Specifications*. If ASB is used for Incidental Stone Base, payment will be made for borrow as referenced above.

Seeding and Mulching will be measured and paid as shown elsewhere in the contract documents. Where ASB is used, seeding and mulching will not be required.

Payment will be made under:

**Pay Item**

Shoulder Reconstruction  
Borrow Excavation

**Pay Unit**

Shoulder Mile  
Cubic Yard

**INCIDENTAL STONE BASE:**

(7-1-95) (Rev.8-21-12)

545

SP5 R28R

**Description**

Place incidental stone base on driveways, mailboxes, etc. immediately after paving and do not have the paving operations exceed stone base placement by more than one week without written permission of the Engineer.

**Materials and Construction**

Provide and place incidental stone base in accordance with Section 545 of the *2018 Standard Specifications*.

**Measurement and Payment**

*Incidental Stone Base* will be measured and paid in accordance with Article 545-6 of the *2018 Standard Specifications*.

**SHOULDER WEDGE:**

(9-20-11) (Rev. 8-21-12)

610

SP6 R03R

Revise the *2018 Standard Specifications* as follows:

**Page 6-21, Article 610-8, SPREADING AND FINISHING**, add the following after line 39:

Attach a device, mounted on screed of paving equipment, capable of constructing a shoulder wedge with an angle of 30 degrees plus or minus 4 degrees along the outside edge of the roadway, measured from the horizontal plane in place after final compaction on the final surface course. Use an approved mechanical device which will form the asphalt mixture to produce a wedge with uniform texture, shape and density while automatically adjusting to varying heights.

Payment for use of this device will be incidental to the other pay items in the contract.

**PRICE ADJUSTMENT - ASPHALT BINDER FOR PLANT MIX:**

(11-21-00)

620

SP6 R25

Price adjustments for asphalt binder for plant mix will be made in accordance with Section 620 of the *2018 Standard Specifications*.

The base price index for asphalt binder for plant mix is \$ **374.50** per ton.

This base price index represents an average of F.O.B. selling prices of asphalt binder at supplier's terminals on **December 1, 2017**.

**SEALING EXISTING PAVEMENT CRACKS:**

(3-22-12)

SPI 6-08

**Description**

The work consists of sealing existing longitudinal and transverse pavement cracks with Sealant Type 2, PS/AR (hot-poured rubber asphalt) at locations as directed by the Engineer. The Contractor will not be required to seal the existing edge joints.

**Materials**

Use Sealant Type 2, PS/AR (hot-poured rubber asphalt) in accordance with Article 1028-2 of the *2018 Standard Specifications*.

**Construction Methods**

Install the sealant so that it forms a complete watertight bond with a high degree of elasticity, with maximum flexibility and longevity under extreme temperature ranges.

Use an HCA (hot compressed air) lance at all times to blast out any vegetation, dirt, dampness and loose materials from the cracks.

Use a concentrated hot air jet that is at least 3000°F in temperature and that has an air jet force of not less than 3000 feet per second of blasting.

Force open asphalt cracks, cleaned warm and dry, and make ready for the application of the preheated sealant for maximum crack sealability.

Preheat the sealant to correct temperature, using the air jacketed flow method to prevent the burning of the modified rubber in the sealant. Perform this by means of a trailer mounted 190 gallon safety tested crack sealant preheater melter kettle, with a horizontally mounted full sweep double paddle agitator.

Apply sealant in the prepared cracks at a temperature range of 370°F minimum and 420°F maximum, using the pressure screed shoe to completely fill the crack, leaving a sealed 2" overband. Excessive overbanding or waste of sealant materials will not be tolerated.

Do not apply the PS/AR sealant when the surface temperature of the pavement is below 32°F.



Seal all cracks with a minimum of 1/8" depth of sealant installed.

After the crack has been sealed, promptly remove surplus sealer on the pavement. Do not permit traffic over the sealed cracks without approval by the Engineer.

The sealant shall be packaged in polyethylene bags and placed in boxes, which weigh approximately 60 pounds. The sealant may be packed in 60 pound boxes containing 2 polyethylene bags of sealant which weigh approximately 30 pounds each. Boxes of sealant are to be palletized for shipment. The pallets are to be protected with a weatherproof covering. The Contractor is responsible for storage.

### **Measurement and Payment**

*Sealing Existing Pavement Cracks* will be measured and paid as the actual pounds of material that has satisfactorily been used to seal pavement cracks in the designated highway. Any material that has been spilled, used in excessive overbanding, wasted, misapplied, or unsatisfactorily used in any way will be deducted in determining quantities for payment. The Engineer will determine the quantity, if any, to be deducted. The Engineer's decision on the quantity to be deducted will be final and binding. The above price and payment will be full compensation for all work required to seal the pavement cracks including, but not limited to, furnishing, hauling, loading and unloading, and storage of all sealant materials; cleaning and preparation of cracks to be sealed; application of sealant material in the prepared cracks; any clean-up; and any incidentals necessary to satisfactorily complete the work.

Payment will be made under:

<b>Pay Item</b>	<b>Pay Unit</b>
Sealing Existing Pavement Cracks	Pound

### **RESURFACING EXISTING BRIDGES:**

(7-1-95) (Rev. 8-21-12)

SP6 R61AR

The Contractor's attention is directed to the fact that he will be required to resurface the bridges on this project if directed by the Engineer.

Place the surface so as to follow a grade line set by the Engineer with the minimum thickness as shown on the sketch herein or as directed by the Engineer. State Forces will make all necessary repairs to the bridge floors prior to the time that the Contractor places the proposed surfacing. Give the Engineer at least 15 days' notice prior to the expected time to begin operations so that State Forces will have sufficient time to complete their work.

At all bridges that are not to be resurfaced, taper out the proposed resurfacing layer adjacent to the bridges to insure a proper tie-in with the bridge surface.

**7" TRENCHING FOR SHOULDER CONSTRUCTION**

(Rev. 6-30-2016)

Div 7 – DDC(Rev)

**Materials:**

Refer to Division 10 of the *Standard Specifications*.

<b>Item</b>	<b>Section</b>
Select Material, Class IV	1016

Perform all trenching necessary to place the proposed 4' Asphalt shoulder in accordance with the typical sections, summary of quantities sheet and as directed by the Engineer. Suitable material from the trenching operation shall be stockpiled on or near the project site at location(s) to be determined by the Engineer. Suitable material shall be used for Shoulder Reconstruction and Incidental Stone. Any excess suitable material will become the property of the Department. All material that is determined to be unsuitable by the Engineer shall become the property of the Contractor and shall be disposed of in an approved disposal site.

Trenching shall be done with a milling machine. The trench shall be the width noted on the Typical Sections +/- 0.1'. If it is necessary to trench wider than the Typical Section due to the equipment used to place the 4' Asphalt Shoulder, the Contractor will be required to backfill the remaining portion of the trench with suitable material excavated from the trench at no cost to the Department, and to retrench to the proper width prior to removal of lane closure devices.

Perform the trenching for shoulder construction on the same day that the 4' Asphalt Shoulder is to be placed. If the paved shoulder cannot be placed on the same day the trench section is excavated, backfill the trench with material removed from the existing shoulder and compact it to the satisfaction of the Engineer. Once the trench is open, perform backfilling and re-opening of the trench at no cost to the Department.

The Contractor will be restricted to shoulder construction on one side in each direction at a time unless otherwise permitted by the Engineer. In shoulder construction, operate equipment and conduct operations in the same direction as the flow of traffic.

The excavated material shall be placed directly into dump trucks & stock piled on or near the project site at locations directed by the Engineer.

Prior to the paving operation, the Contractor shall remove & backfill the existing shoulder drain pipe with material from the existing shoulder, compact the existing material to the satisfaction of the Engineer and proof roll. If an area fails proof rolling, stabilize with Select Material, Class IV or as directed by the Engineer.

Upon completion of the shoulder construction operation each night, the Contractor shall backfill any remaining portion of the trench prior to removal of lane closure to the satisfaction of the Engineer.

*7" Trenching for Shoulder Construction* to be paid will be the actual number of square yards of existing paved shoulder removed and replaced with new 4' Asphalt. No payment for trenching will be made for areas outside of the existing paved shoulder.

The quantity of *Select Material, Class IV* to be paid for at the unit price established herein will be the actual number of tons of aggregate which has been incorporated into the completed and accepted work.

The unit price for 7" *Trenching for Shoulder Construction* will be full compensation for all work covered by this provision and applicable sections of the *Standard Specifications* for furnishing all labor, tools, equipment, and incidents for doing all work involved with 7" *Trenching for Shoulder Construction* included but not limited to, removal of existing shoulder, removal of existing shoulder drains, hauling, stockpiling on or near project site as directed by the Engineer, compacting remaining shoulder material at the direction of the Engineer, proof rolling, correcting areas that failed proof rolling at the direction of the Engineer, placement and maintaining traffic control devices in order to keep vehicular traffic off of new shoulder for a minimum of 3 days.

**Pay Item**

7" Trenching For Shoulder Construction  
Select Material, Class IV

**Pay Unit**

Square Yard  
Ton

**SEALING EXISTING PAVEMENT CRACKS (Polymer Patch):**

(5-4-07)(5-19-09)

SPI 7-05A

**Description**

The Contractor shall prepare and clean the cracks in failing concrete and shall place Polypatch, Fibrescreed, Fibrecrete or like material that meets the specifications in areas designated by the Engineer. Proper placement shall be performed as described by the manufacturer. The Contractor will not be required to seal the existing edge joints.

All materials shall be delivered unopened in their original containers bearing the manufacturer's label, specifying date of manufacture, batch number, trade name brand, and quantity.

Sufficient material to perform the entire crack or spall repair application shall be in storage at the site or at the Contractors facility prior to any field preparation, so that there will be no delay in procuring the material for each day's application.

Stored materials may be inspected prior to their use and shall meet the requirements of these Special Provisions at the time of use.

Any material which is rejected because of failure to meet the required tests or material that has been damaged so as to cause rejections shall be immediately replaced by the Contractor at no additional cost to the Department.

Each shipment of Polypatch, Fibrescreed, Fibrecrete or like material that meets the Specifications shall be accompanied by Material Safety Data Sheets (MSDS) and a Certificate of Compliance certifying that the materials conform to the requirements of these Special Provisions.

**Materials Requirements**

All materials shall meet the specifications as approved by the Engineer prior to use.

## Material Data:

Specific Gravity	1.8
Application Temperature (degrees)	350°F to 392°F
Application Thickness	400 mils plus
Curing Time	10 – 40 minutes
Shelf Life	unlimited
Flash Point	446°F

**Construction Requirements**

The Contractor shall prepare areas by removing any loose debris by using a pavement breaker, by using a mechanical planer, and other methods as directed by the Engineer. When using a planer, the surface shall be milled out to a width and depth as directed by the Engineer. The recess shall then be cleaned and dried using hot compressed air to thoroughly prepare the surface, removing all debris and loose material. Use a concentrated hot air jet that is a minimum of 3000°F in temperature and that has a minimum air jet force of 3000 feet per second of blasting. Polypatch, Fibrescreed, Fibrecrete or like material shall be immediately poured or screeded to fill the recess, with edges overlapped by 2 inches. While the compound is still molten, a preheated high P.S.V. aggregate shall be applied and then compacted to ensure that the finished repair is flush with the surrounding surface.

When repairing pot holes deeper than 2", that are not adjacent to or spanning the edge of pavement joints or cracks, the Contractor shall include 1/2 - 1" sized washed aggregate at the rate of no more than 50% of volume as directed by the Engineer. Then complete repair as previously stated.

**Measurement and Payment**

*Sealing Existing Pavement Cracks (Polymer Patch)* will be measured and paid for as the actual number of pounds of material that has satisfactorily been used to seal pavement cracks in the designated highway.

Any material that has been spilled, used in excessive overbanding, wasted, misapplied, or unsatisfactorily used in any way will be deducted in determining quantities for payment. The Engineer will determine the quantity, if any, to be deducted. The Engineer's decision on the quantity to be deducted will be final and binding. The above price and payment will be full compensation for all work required to seal the pavement cracks including but not limited to furnishing, hauling, loading and unloading, and storage of all sealant materials; cleaning and preparation of cracks to be sealed; application of sealant material in the prepared cracks; any clean-up; and any incidentals necessary to satisfactorily complete the work.

Payment will be made under:

**Pay Item**

Sealing Existing Pavement Cracks (Polymer Patch)

**Pay Unit**

Pound

**DIAMOND GRINDING CONCRETE PAVEMENT:**

(4-15-08) (Rev 08-16-16)

SPI 7-9

**Description**

Perform the work covered by this provision including but not limited to diamond grinding and regrinding concrete pavement to meet final surface acceptable smoothness requirements detailed in Article 710-7, selecting diamond tipped saw blades and configuration of cutting head; continual removal of residual slurry from pavement and disposal; furnishing all labor, materials, supplies, tools, equipment and incidentals as necessary. Perform this work at locations indicated in the plans or as directed by the Engineer.

Prior to beginning any diamond grinding operations, schedule a pre-grind meeting with grinding subcontractor, Division Construction Engineer, Project Engineer, Area Roadway Engineer, State Pavement Construction Engineer, representatives from the Roadside Environmental Unit and the Materials and Tests Unit.

**Equipment**

Use equipment with diamond tipped saw blades gang mounted on a power driven self-propelled machine with a minimum wheel base length of 15 feet that is specifically designed to smooth and texture Portland Cement Concrete pavement. Utilize equipment that does not cause ravels; aggregate fracture; spalls or disturbance to the longitudinal or transverse joints; or damage and/or strain to the underlying surface of the pavement. Should any of the above problems occur immediately suspend operations.

Provide a minimum 3 feet wide grinding head with 50 to 60 evenly spaced grooves per foot. Prior to designing the grinding head, evaluate the aggregate hardness of the concrete pavement and select the appropriate diamond size, diamond concentration and bond hardness for the individual saw blades.

Provide vacuuming equipment to continuously remove slurry residue and excess water from the pavement as part of the grinding operation. Do not allow the slurry material to flow into a travel lane occupied by traffic or into any drainage facility.

**Method of Construction**

Grind the pavement surface to a uniform appearance with a high skid resistant longitudinal corduroy type texture. Provide grooves between 0.09 and 0.15 inches wide with the land area between the grooves between 0.06 and 0.13 inches wide. Ensure a ridge peak of approximately 0.0625 inches higher than the bottom of the grooves.

Begin and end diamond grinding at lines normal to the pavement centerline. Grind only in the longitudinal direction. All grooves and adjacent passes shall be parallel to each other with no variation. Completely lap adjacent passes with no unground surface remaining between passes and no overlap of more than 1½ inches. Adjacent passes shall be within 1/8 inch of the same height as measured with a 3 foot straightedge. Maintain positive cross-slope drainage for the duration of the grinding operation.

Grind all travel lanes to include auxiliary lanes, ramps and loops with not less than 98 percent of the specified surface being textured by grinding. Grinding of the bridge decks and concrete shoulders will not be required. Remove a minimum 0.0625 inches at all locations except dips. Extra grinding to eliminate minor depressions is not required. It is anticipated that extra grinding will be required on the high side of existing faults in the pavement. There shall be no ridge between lanes. In a separate operation, transition the grinding of any remaining ridges greater than 1/8 inch in height on the outside edge next to the shoulder or at a tie to an existing facility to the satisfaction of the Engineer.

Final surface testing is required on this project in accordance with Article 710-7 of the *2018 Standard Specifications*.

### **Disposal of Residual Slurry**

Diamond grinding slurry disposal shall be in accordance with the Statewide Permit for Land Application of Diamond Grinding Slurry (DGS), Permit No. WQ0035749 dated June 3, 2014. Submit a slurry disposal plan to the Engineer detailing method of handling and disposing of slurry from the diamond grinding operation a minimum of 60 days prior to beginning the diamond grinding operation. Engineer shall review the slurry disposal plan. Plan must be accepted prior to beginning the diamond grinding operation.

Disposal options are:

- (A) Land apply slurry directly from diamond grinding machine within the DOT right-of-way in the median, shoulders and slopes.
- (B) Collect, contain, haul, and land apply slurry within DOT right-of-way as directed by the Engineer and a representative from the Roadside Environmental Unit. Contractor shall disperse slurry through an operation that spreads slurry within allowable agronomic rates in an interchange or designated area.

If the above options for disposal of slurry do not qualify as acceptable methods as determined by the Department, then the Contractor will be compensated under Article 104-7 for any other disposal methods required by the Department.

To prevent the migration of any direct discharge from the diamond grinding machine or land applied DGS from entering a drainage inlet or structure, the contractor shall install wattles and silt fence at the direction of the Engineer. Silt Fence shall be installed in accordance with Section 1605 of the *NCDOT 2018 Standard Specifications*.

For more detailed information, see the Environmental Permits and Guidelines section under Environmental resources on the NC Connect website for the DG permit and guidelines at the following link. (NCID access required.)

<https://connect.ncdot.gov/resources/Environmental/Environmental%20Permits%20and%20Guidelines/Forms/AllItems.aspx>

**Measurement and Payment**

The quantity of *Diamond Grinding PCC Pavement* to be paid for will be the actual number of square yards of pavement which has been satisfactorily diamond ground, measured along the final top surface of the pavement. No separate payment will be made for any overlapping, regrinding, or for extra grinding on the high side of existing faults.

Payment will be full compensation for the work, including but is not limited to grinding, disposal of slurry, final surface testing, furnishing all materials, equipment, labor and all incidentals necessary to satisfactorily complete the work.

*Temporary Silt Fence* will be measured and paid in linear feet, accepted in place, along the ground line of the fence.

*Wattle* will be measured and paid for by the actual number of linear feet of wattles which are installed and accepted. Such price and payment will be full compensation for all work covered by this section, including, but not limited to, furnishing all materials, labor, equipment and incidentals necessary to install the *Wattle*.

Payment will be made under:

**Pay Item**

Diamond Grinding PCC Pavement  
Temporary Silt Fence  
Wattle

**Pay Unit**

Square Yard  
Linear Foot  
Linear Foot

**JOINT CONSTRUCTION, REPAIR AND SEALING:**

(4-15-08) (Rev 11-24-09)

SPI 7-12A

**Description**

Saw existing backer rods joints, saw existing sawed joints, remove existing deteriorated backer rods and clean and seal joints with Low Modulus Silicone in accordance with the detail in the plans and the manufacturer's recommendations. Also, repair and reseal existing joints with Low Modulus Silicone, form joints in slab replacements and seal with Low Modulus Silicone in accordance with Standard Drawing No. 700.01.

**Materials**

Low Modulus Silicone Sealant shall meet the requirements of Section 1028-3(A) of the *Standard Specifications* for Low Modulus Silicone Sealant; and shall be on the Department's approved product listing that is being evaluated by National Transportation Product Evaluation Program (NTPEP).

**Construction**

Have on-site, a manufacturer's representative during the initial start-up. This requirement will be suspended once the Engineer determines that the installation process is working smoothly.

Saw and seal pavement joints, and form control joints in one lane at a time.

Saw and seal joints at locations shown on the plans or as directed by the Engineer.

Saw and seal the centerline longitudinal joint according to Standard Drawing No. 700.01.

Form control joints in the proposed replacement slabs according to the spacing and dimensions as shown on the plans. Form the control joints by sawing with an approved concrete saw. Saw as soon as the concrete has hardened sufficiently without spalling or raveling, but before the lane is reopened to traffic, and not more than 6 hours after the concrete is placed.

Equip air compressors for cleaning joints with suitable traps capable of removing all surplus water and oil in the compressed air. The Engineer will check the compressed air daily for contamination. Do not use contaminated air.

Cleaning and sealing shall be as follows:

**(A) Cleaning Freshly Cut Sawed Joints**

Immediately after sawing the joint, completely remove the resulting slurry from the joint and the immediate area by flushing with a jet of water under pressure, and other tools as necessary. After flushing, blow out the joint with compressed air. After the surfaces are thoroughly clean and dry and just before the joint sealer is placed, blow out the joint with compressed air having a pressure of at least 90 psi and remove all traces of dust. If freshly cut sawed joints become contaminated before they are sealed, clean as many times as necessary with cleaning methods approved by the Engineer.

**(B) Installing Backup Material**

When required, install closed cell, expanded polyethylene foam rod type backup material in a manner that will produce the shape factor specified. If the sealant bonds to the backup material, a bond-breaking type may be required.

**(C) Taping Expansion Joints**

When the joints have been cleaned and are thoroughly dry, place bond-breaking adhesive tape on top of the joint material or backup material to prevent any bonding action between the bottom of the joint sealer and the top of underlying material. The tape shall completely cover the top of the underlying material, but at no place shall the tape be allowed to adhere to the sides of the joint.

**(D) Sealing Joints Requirements**

- (1) Place joint sealer in accordance with the manufacturer's recommendations and these Specifications. Do not place silicone joint sealer when the air temperature near the joint is less than 50°F or is 50°F and falling or between October 15 and May 1, unless otherwise directed by the Engineer.



- (2) **Filling the Joint:** Do not seal a joint until the seal is thoroughly clean and dry, and properly taped, if taping is required. Place the sealer in reasonably close conformity with dimensions shown on the plans. The joints will be rejected for any unreasonable deviation until satisfactory corrective measures are taken.

Apply the joint sealer by an approved mechanical device or by manually pouring or troweling, depending upon the consistency used. When applied mechanically or by pouring, a nozzle or pouring spout shall be shaped to fit inside the joint to introduce the sealer from inside the joint. Pouring consistency shall be used in horizontal joints, and troweling consistency shall be used in vertical joints, unless the pouring consistency is such that it can be satisfactorily placed in vertical joints.

Recess the joint sealer below the adjacent surface as shown in Standard Drawing No. 700.01.

If the joint material fails in either adhesion or cohesion, the joint shall be repaired to the Engineer's satisfaction at the Contractor's expense.

- (3) **Special Requirements for Installation of Low Modulus Silicone Sealant:** The sealant shall be tooled to provide the required recess. The sealant shall be tooled or applied in a manner which causes it to wet the joint faces.
- (4) **Cleaning Pavement:** Promptly remove surplus joint sealer on the pavement after a joint has been sealed so that the joint sealer is not exposed to direct contact with traffic.

**(E) Opening to Traffic**

Do not permit traffic over sealed joints without the approval of the Engineer.

**Measurement and Payment**

*Joint Construction, Repair and Sealing* will be measured and paid for at the contract unit price of the actual number of linear feet of joints, which are satisfactorily constructed, repaired and sealed. The length will be measured along the joints that have been constructed or repaired and sealed. Such price and payment will be full compensation for this work, including but not limited to removal and disposal of existing joint sealant and backer rod, preparation of joints, and furnishing all labor, tools, materials, and supplies, tools equipment and incidentals needed to complete the work.

Payment will be made under:

**Pay Item**

Joint Construction, Repair and Sealing

**Pay Unit**

Linear Foot

**ROLLER COMPACTED CONCRETE**

(05-17-16)

1000

SPI 7-18

**Description**

Construct Roller Compacted Concrete (RCC) pavement on a prepared base, in accordance with these provisions and with lines, grades, thicknesses, and typical sections as shown on the plans. This work includes, but is not limited to, the designing of the mix; producing, furnishing and placing of the concrete; compaction; finishing; constructing joints; curing the pavement; coring for test specimens and associated patching of the pavement; and quality control testing.

Submit the following for approval a minimum of 30 days prior to the start of any production of RCC:

- (A) Submit RCC mix design in accordance with Section 1000-3(A) of the 2018 *Standard Specifications* except as noted herein. The submitted design shall minimally include aggregate gradation, cementitious materials, admixtures (if used), compressive strength (minimum 4,500 psi at 28 days), required moisture and density to be achieved and quantities of individual materials per cubic yard for the mix design. Minimum cement content per cubic yard is 450 pounds. Measurement and reporting of flexural strength is not required.
- (B) Submit a Process Control Plan detailing the personnel, equipment, production, placement, compaction, sampling, testing and repair operations.

Schedule a pre-pave meeting prior to installing the RCC including representatives from the Contractor, Subcontractor, Project Engineer, Area Roadway Construction Engineer, the State Pavement Construction Engineer and a representative from the Materials and Tests Unit.

**Materials**

- (A) General

All materials shall meet the requirements of the *2018 Standard Specifications*.

<b>Item</b>	<b>Section</b>
Portland Cement Concrete	1000
Curing Agents	1026
Joint Filler	1028-1
Low Modulus Silicone Sealant	1028-4
Water	1024-4

- (B) Aggregates

Furnish aggregates conforming to Section 1014 of the *2018 Standard Specifications*. The plasticity index of the aggregate shall not exceed five. Provide a well-graded aggregate blend conforming to the following gradation:

<b>GRADATION FOR ROLLER COMPACTED CONCRETE AGGREGATE</b>	
<b>Sieve Size</b>	<b>% Passing by Weight</b>
1"	100
3/4"	95 - 100
1/2"	70 - 90
3/8"	60 - 85
No. 4	40 - 60
No. 8	30 - 50
No. 16	20 - 40
No. 100	0 - 18
No. 200	0 - 8

Other aggregate blends may be considered provided demonstration of past performance and mix approval prior to production.

### **Equipment**

(A) General

Provide maintained equipment and tools that will produce a completed RCC pavement meeting the requirements of this provision. All equipment shall be on site, inspected and in good operating condition before work may proceed.

(B) Concrete Mixing Plant

A pugmill plant shall be a central plant with a twin shaft pugmill mixer, capable of batch and continuous mixing, equipped with synchronized metering devices and feeders to maintain the correct proportions of aggregate, cement, mineral admixtures, and water. Other pugmill plant requirements are as follows:

Ensure that all aggregate stockpiles have adequate separation to prevent cross contamination and are handled in a manner that prevents segregation.

Control feed rate by a variable speed belt or an operable gate calibrated to accurately deliver any specified quantity of material. If two or more aggregate stockpiles are used, the feed rate from each bin shall be readily adjustable to change aggregate proportions, when required. Feed rate controls must maintain the established proportions of aggregate from each stockpile bin when the combined aggregate delivery is increased or decreased.

Operate plant scales in accordance with Sub-article 1000-9(C) of the 2018 *Standard Specifications*.

Minimize segregation during loading of delivery trucks. Loading directly from a belt or auger will not be permitted.

**(C) Paver**

Utilize a high density paver, which provides a minimum of 90% of the maximum wet density in accordance with ASTM D1557 or equivalent test method at placement.

Provide a paver of suitable weight and stability to spread and finish the RCC material, without segregation, to the required thickness, smoothness, surface texture, cross-section and grade.

**(D) Compactors**

Provide self-propelled steel drum vibratory rollers having a minimum static weight of 10 tons for primary compaction. Provide rollers equipped with controls that automatically disengage the vibration mechanism before the roller stops. For final compaction, use a combination of self-propelled steel drum roller, in static mode, and a rubber tire roller weighing between 4 and 10 tons as necessary to achieve an acceptable surface.

Use walk-behind vibratory rollers or plate tampers for compacting areas inaccessible to the large rollers. Ensure that areas compacted with walk-behind equipment meet all requirements for compaction and surface quality. If sufficient compaction and texture cannot be achieved with walk-behind equipment, use conventional concrete in the inaccessible areas.

**(E) Water Trucks**

Provide at least one water truck or other similar equipment on-site capable of evenly applying a fine spray of water to dampen the base or subgrade surface ahead of RCC placement and to keep the surface of the RCC moist without damaging the final surface.

**(F) Hauling Equipment**

Use non-agitating hauling equipment having bodies which are smooth, watertight, metal containers equipped with vibrators and gates to discharge the concrete without segregation or damage. Provide fitted covers to protect the material from rain and excessive evaporation.

Prevent the accumulation of hardened concrete in the delivery vehicles, providing a washout station, if necessary, to prevent the accumulation of material. Discharge all flushing water before charging with the next RCC load.

**(G) Concrete Saws**

Use early-entry concrete saws that are capable of sawing the concrete the same day as placement and as soon as the concrete can be cut for crack control without raveling and to the depth required. Once hardened, use standard wet saw-cutting equipment if additional saw cuts are necessary. Equip all saws with blade guards and guides or devices to control alignment and depth.

**Preparation of Subgrade and Base**

Prior to the placement of RCC pavement, verify the subgrade and base has proper density and grade tolerances in accordance with Section 500-3 of the 2018 *Standard Specifications for Roads and Structures* and repair any soft or yielding areas. Correct all damaged areas in the subgrade or base prior to placing concrete. Keep the base clean and free of foreign material.

Dampen the surface of the base uniformly at the time the RCC pavement mixture is placed. Ensure that no free water or ponding is present at the time of concrete placement.

**Weather Limitations****(A) Cold Weather**

Do not place RCC when any of the following conditions exist:

- (1) When base contains frost or frozen material.
- (2) When the air temperature is 35°F and descending.

Maintain a sufficient supply of insulating blankets, plastic sheeting or other suitable material. Apply insulating materials to maintain a minimum temperature of 40°F at the pavement surface for a minimum of five days.

**(B) Hot Weather Precautions**

Do not place RCC when the air temperature is 90°F and rising and RCC temperature is greater than 95°F.

**(C) Rain**

Do not place RCC pavement during rain conditions sufficient to be detrimental to the finished product. Placement may continue during drizzle or mist conditions provided the surface of the RCC pavement is not eroded or damaged in any way. The Engineer will be the sole judge as to when placement must be stopped due to rain.

**Construction Methods****(A) Delivery**

Provide a sufficient number of trucks to ensure an adequate and continuous supply of RCC material to the paver. Deliver the concrete to the work site in a thoroughly mixed and uniform mass. Minimize the elapsed time to be 45 minutes or less, unless longer times can be demonstrated to provide acceptable performance to the satisfaction of the Engineer. The Engineer may rescind approval for longer elapsed times if the performance becomes unsatisfactory due to changes in weather, materials, or any other pertinent reason. The elapsed time is defined as the period from first contact between mixing water and cement until the entire operation of placing and compacting, including corrective measures if necessary, has been completed.

**(B) Placement**

Deposit the RCC material into a material transfer vehicle prior to placing into the hopper of the paver.

If at discharge, the concrete is not thoroughly mixed and homogeneous, the charging sequence, size of load, mixing time or any combination thereof should be altered to meet these requirements; otherwise, utilize other equipment capable of delivering a thoroughly mixed and uniform concrete mass.

Maintain an adequate quantity of RCC in the paver and do not allow the paver to become empty between loads. Maintain the material above the auger shaft at all times during paving.

Operate the paver in a manner that will prevent segregation and produce a smooth continuous surface without excessive tearing, pulling or shoving. Limit the placement of RCC to a length that can be compacted and finished within the appropriate time limit under the prevailing air temperature and wind conditions.

Advance the paver in a steady, continuous operation with minimal starts and stops. Limit the paver speed during placement operations to ensure that density requirements are met and surface distress is minimized.

Broadcasting or fanning the RCC material across areas being compacted will not be permitted. Such additions of material shall only be done immediately behind the paver and before any compaction has taken place. Any segregated coarse aggregate shall be removed from the surface before rolling.

If segregation occurs in the RCC during paving operations, the placement shall cease and the segregated materials shall be removed and replaced with fresh RCC before rolling.

**(C) Compaction**

Immediately after the concrete has been placed, thoroughly and uniformly compact the pavement.

Determine the sequence and number of roller passes by vibratory and non-vibratory rolling to obtain the specified density and surface finish. Avoid displacement of the RCC pavement. Immediately correct any displacement of the surface resulting from reversing or turning action of the roller. Smooth any uneven marks left during the vibrating rolling with a steel drum or rubber tire roller(s) operated in static mode. Provide a final surface meeting the smoothness and finish grade requirements of this section, and free of excessive surface tears and cracks.

Areas inaccessible to either the paver or rollers may be placed by hand and compacted with equipment specified within this provision. Compaction of these areas must satisfy the same minimum density requirements as specified below. An alternate and preferred method for paving inaccessible areas is to use cast-in-place, air-entrained concrete with a minimum compressive strength of 4,000 psi.

Provide additional rolling to longitudinal joints as necessary to produce the specified density for the full depth of the lift and produce a tight smooth joint.

(D) Density Testing

The RCC pavement will be evaluated for density on a lot by lot basis. A lot will consist of 2,000 SY of newly placed RCC. In-place field density tests shall be performed in accordance with ASTM C 1040, direct transmission, as soon as possible, but no later than 30 minutes after completion of rolling at three randomly selected locations within the lot that are no closer than 12 inches from a free edge or 6 inches from a confined edge. Only wet density shall be used for evaluation. Based on these three tests, an average density not less than 98% of the maximum wet density obtained by ASTM D 1557 or equivalent test method is required, with no individual test less than 96%.

In addition to determining the density within the mat, determine the in-place wet joint density on joints at three random locations at a of distance 12 inches from a free edge or 6 inches from a confined edge, as appropriate. The average of three wet joint density tests shall be not less than 96% and none of the density tests shall be less than 94% of the maximum wet density obtained by ASTM D 1557 or equivalent test method.

If the Engineer determines that a given lot does not meet the minimum specification density requirements but the work is reasonably acceptable, the lot will be accepted at a reduced pay factor in accordance with the following formula. The reduced pay factor will apply only to the RCC unit price.

$$\text{Reduced Pay Factor} = 100 + \left[ \frac{\text{Actual Density} - \text{Specified Density}}{2} \right] * 25$$

Where:

**Actual Density** = the lot average density, not to exceed 4.0% of the specified density

**Specified Density** = the wet density or joint density specified in the contract

Any density lot not meeting minimum density requirements will be evaluated for acceptance in accordance with Article 105-3.

(E) Strength Testing

(1) Mix Design

The proposed RCC mix design shall have a minimum compressive strength of at least 4,500 psi in accordance with ASTM C39 based on test results of 6"x12" cylinders prepared in accordance with ASTM C1435. Cure and transport specimens to the laboratory in accordance with ASTM C 31.

(2) Production Quality Control Strength Testing

The RCC pavement will be evaluated for compressive strength on a lot by lot basis. A lot will consist of 2,000 SY of newly placed RCC or a fraction thereof. Obtain one sample of fresh RCC during the placement of each lot and make at least three

6" X 12" cylinders in accordance with ASTM C1435. The average of two cylinders tested at 28 days shall be the compressive strength for that lot.

(F) Curing

After final finish and immediately after the free surface moisture has disappeared, apply curing compound at a rate of 0.0067 gallons per square foot. Provide an inline flow metering device to ensure the proper application rate is provided. Apply the curing compound such that puddling or ponding does not occur on the fresh concrete surface.

(G) Finishing

The finished surface of the RCC pavement, when tested with a 10 foot straight edge or crown surface template, shall not vary from the straight edge or template by more than 3/8 inch at any one point. When the surface smoothness is outside the specified surface tolerance, the surface shall be grinded to within the tolerance by use of a self-propelled diamond grinder. Milling of the final surface is not acceptable.

(H) Joint Construction

Construct joints to assure continuous bond between new and previously placed lanes. A vertical joint is considered a fresh joint when an adjacent RCC lane is placed no later than 60 minutes of placing the previous lane. This time may be reduced by the Engineer when conditions such as hot, dry, and/or windy weather are encountered. The Engineer may further require measures to keep the fresh joint moist, including but not limited to wetting or moist burlap. Cold vertical joints are any planned or unplanned construction joints that do not qualify as fresh joints.

Cold vertical joints may be formed through the use of an edging shoe after successful demonstration that the procedure meets the minimum joint density requirements of this section and the edging shoe produces a face with no more than an angle of 10 degrees from vertical. If the edging shoe is not used or cannot meet the specification requirements, remove a minimum of 6 inches along the entire edge by saw cutting the full depth of the RCC pavement. Saw cutting operations must not produce excessive raveling along the surface of the cut.

Prior to placing fresh RCC mixture against a compacted cold vertical joint, the joint shall be thoroughly cleaned of any loose or foreign material and in a moist condition immediately prior to placement. The joints between RCC pavement and concrete structures shall be treated as cold vertical joints.

Construct all contraction joints within RCC pavement in accordance with the plans and Article 700-11 of the *2018 Standard Specifications*. Seal contraction joints in accordance with Article 700-12 (excluding 700-12 (B) Age of Pavement) of the *2018 Standard Specifications*.

(I) Opening to Traffic

Heavy truck traffic and other heavy equipment will not be allowed on the RCC pavement until representative concrete test cylinders achieve 3,000 psi and at least 3 days old. All compressive strength concrete test cylinders shall be made and tested in accordance with



ASTM 1435 and AASHTO T22. However, limited automobile and light truck traffic may be allowed on the RCC as soon as the concrete is sufficiently cured to prevent significant marring.

No permanent traffic will be allowed on the pavement until construction of the joints, including all sawing, sealing, and curing that is required, has been completed.

**Thickness Acceptance**

The thickness of the pavement will be determined by measurement of cores. One core will be taken from each lot at a random location selected by the Engineer.

The thickness of the RCC pavement shall not deviate from that shown on the plans by more than minus 0.5 inches. When the measurement of any core is less than the plan thickness by more than 0.5 inches, the actual thickness of the pavement in this area will be determined by taking additional cores at not less than 10 foot intervals parallel to the center line in each direction from the affected location until a core is found in each direction which is not deficient by more than 0.5 inches. Areas found deficient in thickness by more than 0.5 inches will be removed full shoulder width and replaced with concrete of the thickness shown on the plans. No overlays shall be accepted.

**Strength Acceptance**

The minimum compressive strength of RCC field cylinder specimens shall be at least 4,500 psi. The RCC pay factor for pavement achieving a compressive strength in 28 days of 4,500 psi or greater is 100%. The pay factor for pavement achieving a compressive strength in 28 days between 3,500 psi and 4,500 psi is determined by the following formula:

$$\text{Pay Factor (\%)} = 100.0 - [0.05(4500 - \text{Compressive Strength})]$$

(pay factor rounded to nearest 0.1%)

If the average compressive strength of the three cores per Lot is less than 4500 psi, then the area will be evaluated in accordance with Article 105-3 of the 2018 *Standard Specifications for Roads and Structures*.

**Test Section**

At least 7 days before the start of paving operations, construct a test section using the approved concrete mix design. Provide a minimum test section of 300 feet in length. Use the same equipment, materials, techniques, and personnel in the test section that will be used to construct the production RCC pavement. If approved by the Engineer, the test section may be incorporated into the production section.

The Engineer shall evaluate the following criteria from the test section:

- Adequacy of mixing plant to meet productivity requirements and produce consistent material.
- Maximum density directly behind the paver prior to roller compaction.
- Sequence of primary/ secondary roller passes (with and without vibration).
- Maximum density following roller compaction.
- Texture and surface finish acceptability.
- Integrity of proposed edging shoes, edge compaction, and jointing methods.

- RCC compressive strength based on cylinders and extracted cores tested at 7 and 28 days.

Verify the correlation between the compressive strength of extracted cores and compressive strength of field cylinder specimens. A representative area of the test section should be identified and samples of the material used to construct this area collected for the fabrication of cylinders. The final density of the subject area shall be determined and recorded.

### **Measurement and Payment**

*Roller Compacted Concrete* will be measured and paid for at the unit price for the actual number of square yards of RCC which has been completed and accepted. In measuring this quantity, the width of the repair will be measured perpendicular to the centerline of the lane. The length will be the actual length constructed, measured along the centerline of the pavement.

The unit price for RCC will be full compensation for all work covered by this provision, and applicable sections of the *2018 Standard Specifications* for furnishing all labor, materials, tools, equipment, and incidentals for doing all work involved in placement of the RCC including but not limited to furnishing placing, and curing concrete; sawing and removing concrete; and filling saw cuts around the pavement repair.

Payment will be made under:

#### **Pay Item**

Roller Compacted Concrete

#### **Pay Unit**

Square Yard

### **8" TRENCHING FOR SHOULDER CONSTRUCTION**

(Rev 10-16-17)

Div 9 Rev

Perform all trenching necessary to place the proposed 10' Roller Compacted Concrete shoulder in accordance with the typical sections, summary of quantities sheet and as directed by the Engineer. Suitable material from the trenching operation shall be stockpiled on or near the project site at location(s) to be determined by the Engineer. Suitable material shall be used for Shoulder Reconstruction and Incidental Stone. Any excess suitable material will become the property of the Department. All material that is determined to be unsuitable by the Engineer shall become the property of the Contractor and shall be disposed of in an approved disposal site.

Trenching shall be done with a milling machine. The trench shall be the width noted on the Typical Sections +/- 0.1'. If it is necessary to trench wider than the Typical Section due to the equipment used to place the 10' Roller Compacted Concrete Shoulder, the Contractor will be required to backfill the remaining portion of the trench with suitable material excavated from the trench at no cost to the Department, and to retrench to the proper width prior to removal of lane closure devices.

Perform the trenching for shoulder construction on the same day that the 10' Roller Compacted Concrete shoulder is to be placed. If the paved shoulder cannot be placed on the same day the trench section is excavated, backfill the trench with material removed from the existing shoulder and compact it to the satisfaction of the Engineer. Once the trench is open, perform backfilling and re-opening of the trench at no cost to the Department.



<b><u>PROPERTY</u></b>	<b><u>TEST</u></b>	<b><u>RESULTS</u></b>
Density	ASTM D 1622	3.8-4.2 pcf
Compressive Strength	ASTM D 1621	60 psi
Tensile Strength	ASTM D 1623	60 psi
Shear Strength	ASTM C 273	40 psi
Closed Cell content	ASTM 2858	85%

2. The material shall obtain 90% compressive strength within 30 minutes of injection and be a polyurethane-forming mixture, having a water insoluble diluent, which permits the formation of polyurethanes in excess water.
3. Provide Type 3 material certifications for the material in accordance with Article 106-3 of the *Standard Specifications*. Provide a copy of the MSDS for the components of the material to the Engineer.
4. Non-shrink grout to patch drill holes. Supplied by an approved manufacturer. Use within the shelf life and temperature limitation set by the manufacturer.

### **Construction Requirements**

Schedule a pre-placement meeting prior to the beginning of slab stabilization with representatives from the Contractor, Subcontractor, Manufacturer, Project Engineer, Roadway Construction Engineer, Pavement Management Unit, Materials and Tests Unit, and State Pavement Construction Engineer.

The repair material shall not be placed when the temperature of the subgrade material is below 32 degrees F.

The installer shall submit a project specific Quality Control (QC) Plan detailing the installers key personnel (including contact information), equipment to be used, materials, proposed methods of pavement surface preparation including but not limited to crack sealing, cleaning, sweeping and drying, drilling methods and procedures, tube installation, deep injection of material, and proper cleaning methods. The Contractor shall submit the QC Plan to the Engineer a minimum of 7 days prior to placement of material.

### **Equipment**

**Truck mounted Pumping Units.** As a minimum, provide a truck with one mounted unit capable of injecting the polyurethane material at a controlled rate, into the aggregate base, subbase, or foundation soils to the required depth, and capable of controlling the rate of rise of the pavement. A second unit with the identical specifications shall be available at the work location for unforeseen failure of the main unit. The secondary unit may be attached to the same truck or a separate vehicle. The pumping units shall work together in such a manner that down time is minimized and does not affect the quality and performance of the polyurethane material. Pumping units are equipped with certified flow meters to precisely measure the amount of each component injected so that the 1:1 ratio by volume is maintained for quality control and for accurate measurement of material for payment. The certified flow meter shall have a digital output to show both pounds and gallons of each component material. Units shall be equipped with pressure and temperature control

devices capable of maintaining proper temperature and proportionate mixing of the chemical components.

Drill. The Contractor shall use Pneumatic or electric drills capable of efficiently drilling 5/8" to 2" diameter injection holes through concrete pavement without damaging the structural integrity of the existing pavement. Drill host holes for the placement of injection tubing cut to proper length(s) as indicated on the field QC plan and dynamic cone penetrometer testing.

Equipment for Monitoring Movement. Supply satisfactory equipment such as rotating laser levels and receivers to monitor movement of pavement to within 1mm to verify that the injected foundation soils have been properly densified and to ensure proper lift of pavement to grade if required. Supply satisfactory differential fault meters to monitor movement of bridge approach at abutment walls and for correction of faulted jointed pavement. Supply satisfactory horizontal movement monitoring equipment when injecting in the vicinity of MSE walls.

**Procedure:**

1. Drilling Holes and Installation of Injection Tubes. Drill injection holes in the pattern as indicated on the field QC plan. Drill holes 5/8 - 2 inches in diameter, vertical and round, and to a depth indicated on the approved field QC plan. Install injection tubes to the prescribed injection depth or depths.
2. Mixing. Using the flow meters, a quality check shall be performed on the ratio of the two part chemical system. The part A (Resin) to the part B (ISO) ratio by volume should be 1:1. Prior to performing the work each day, the Contractor shall reset the flow meters on the pumping units to zero. The contractor shall perform a test shot of material from one gun at a time with a minimum of 0.5 gallons of each material, comparing the digital output in gallons of resin to the gallons of ISO to determine the injected ratio. If the ratio is less than 0.95 or greater than 1.05, the system shall be checked for problems, adjusted, and the ratio rechecked until a proper ratio is assured. Contractor shall repeat the quality check for all the injection guns to be used on the project.
3. Foundation Soil Stabilization. Inject the high density polyurethane material via injection tubes into the foundation soils beneath the pavement to the prescribed depth or depths in a top down manner. Control the stabilization of the foundation soils by regulating the rate of injection of the material. Continuously monitor for movement of the pavement. Foundations soils are sufficiently stabilized when movement of the pavement is detected. Injection may continue into the soils as needed to lift the pavement to grade, returning the pavement system to original construction grade, on top of a stiffened subbase or subgrade. If no vertical movement has occurred, the Engineer may direct the Contractor to cease pumping.
4. Hole Patching. Push down or drill out injection tubing to 2" below the pavement surface and install a rapid set, non-shrink patching material into the drilled out hole. Strike patches flush with the surface of the surrounding pavement.
5. Opening to Traffic. Injected pavement should be at a minimum 90% strength and opened to traffic within 30 minutes of final injection of polyurethane or as approved by the Engineer. Pavement shall be free of debris and swept clean prior to opening to traffic.

**Warranty**

A two-year warranty against movement of more than ½” of the pavement. In the event that movement of more than ½” in the injected areas occurs, Contractor shall return to inject the affected area to lift to proper grade at no additional cost to the Department.

**Measurement and Payment**

*Pavement Slab Stabilization Material* will be measured and paid in pounds at the contract unit bid price for the pay item. Pounds as measured by certified flow meters on each of the two chemical components and totaled to indicate total pounds of material. Payment per pound includes but not limited to stabilizing slabs as specified or directed and includes furnishing, hauling, surface preparation, drilling, installation of tubing, deep injection, cleaning and incidentals necessary to fulfill the requirements of this pay item in accordance with the Plans, the Specifications and other terms of the Contract. Some material waste is expected as part of the injection process; however, payment for excessive waste material as determined by the Engineer shall not be made.

**Pay Item**

Pavement Slab Stabilization Material

**Pay Unit**

Pounds

**EROSION AND STORMWATER CONTROL FOR SHOULDER CONSTRUCTION AND RECONSTRUCTION:**

(11-16-10) (Rev. 8-21-12)

105-16, 225-2, Division 16

SP16 R03R

Land disturbing operations associated with shoulder construction/reconstruction may require erosion and sediment control/stormwater measure installation. National Pollutant Discharge Elimination System (NPDES) inspection and reporting may be required.

Erosion control measures shall be installed per the erosion control detail in any area where the vegetated buffer between the disturbed area and surface waters (streams, wetlands, or open waters) or drainage inlet is less than 10 feet. The Engineer may reduce the vegetated buffer threshold for this requirement to a value between 5 and 10 feet. Erosion control measures shall be spot checked every 14 days until permanent vegetative establishment.

In areas where shoulder construction/reconstruction includes disturbance or grading on the front slope or to the toe of fill, relocating ditch line or backslope, or removing vegetation from the ditch line or swale, NPDES inspection and monitoring are required every 14 days or within 24 hours of a rainfall event of 0.5 inch or greater. Maintain daily rainfall records. Install erosion control measures per detail.

In areas where the vegetated buffer is less than 10 feet between the disturbed area and waters of the State classified as High Quality Water (HQW), Outstanding Resource Water (ORW), Critical Areas, or Unique Wetlands, NPDES inspection and monitoring are required every 14 days or within 24 hours of a rainfall event of 0.5" or greater. The Engineer may reduce the vegetated buffer threshold for this requirement to a value between 5 and 10 feet. The plans or provisions will indicate the presence of these water classifications. Maintain daily rainfall records. Install erosion control measures per detail.

Land disturbances hardened with aggregate materials receiving sheet flow are considered non-erodible.

Sites that require lengthy sections of silt fence may substitute with rapid permanent seeding and mulching as directed by the Engineer.

NPDES documentation shall be performed by a Level II Erosion and Sediment Control/Stormwater certificate holder.

Materials used for erosion control will be measured and paid as stated in the contract.

**STANDARD SPECIAL PROVISION**  
**AVAILABILITY OF FUNDS – TERMINATION OF CONTRACTS**

(5-20-08)

Z-2

*General Statute 143C-6-11. (h) Highway Appropriation* is hereby incorporated verbatim in this contract as follows:

(h) Amounts Encumbered. – Transportation project appropriations may be encumbered in the amount of allotments made to the Department of Transportation by the Director for the estimated payments for transportation project contract work to be performed in the appropriation fiscal year. The allotments shall be multiyear allotments and shall be based on estimated revenues and shall be subject to the maximum contract authority contained in *General Statute 143C-6-11(c)*. Payment for transportation project work performed pursuant to contract in any fiscal year other than the current fiscal year is subject to appropriations by the General Assembly. Transportation project contracts shall contain a schedule of estimated completion progress, and any acceleration of this progress shall be subject to the approval of the Department of Transportation provided funds are available. The State reserves the right to terminate or suspend any transportation project contract, and any transportation project contract shall be so terminated or suspended if funds will not be available for payment of the work to be performed during that fiscal year pursuant to the contract. In the event of termination of any contract, the contractor shall be given a written notice of termination at least 60 days before completion of scheduled work for which funds are available. In the event of termination, the contractor shall be paid for the work already performed in accordance with the contract specifications.

Payment will be made on any contract terminated pursuant to the special provision in accordance with Subarticle 108-13(E) of the *2018 Standard Specifications*.



**STANDARD SPECIAL PROVISION**  
**NCDOT GENERAL SEED SPECIFICATION FOR SEED QUALITY**

(5-17-11)

Z-3

Seed shall be sampled and tested by the North Carolina Department of Agriculture and Consumer Services, Seed Testing Laboratory. When said samples are collected, the vendor shall supply an independent laboratory report for each lot to be tested. Results from seed so sampled shall be final. Seed not meeting the specifications shall be rejected by the Department of Transportation and shall not be delivered to North Carolina Department of Transportation warehouses. If seed has been delivered it shall be available for pickup and replacement at the supplier's expense.

Any re-labeling required by the North Carolina Department of Agriculture and Consumer Services, Seed Testing Laboratory, that would cause the label to reflect as otherwise specified herein shall be rejected by the North Carolina Department of Transportation.

Seed shall be free from seeds of the noxious weeds Johnsongrass, Balloonvine, Jimsonweed, Witchweed, Itchgrass, Serrated Tussock, Showy Crotalaria, Smooth Crotalaria, Sicklepod, Sandbur, Wild Onion, and Wild Garlic. Seed shall not be labeled with the above weed species on the seed analysis label. Tolerances as applied by the Association of Official Seed Analysts will NOT be allowed for the above noxious weeds except for Wild Onion and Wild Garlic.

Tolerances established by the Association of Official Seed Analysts will generally be recognized. However, for the purpose of figuring pure live seed, the found pure seed and found germination percentages as reported by the North Carolina Department of Agriculture and Consumer Services, Seed Testing Laboratory will be used. Allowances, as established by the NCDOT, will be recognized for minimum pure live seed as listed on the following pages.

The specifications for restricted noxious weed seed refers to the number per pound as follows:

<b><u>Restricted Noxious Weed</u></b>	<b><u>Limitations per Lb. Of Seed</u></b>	<b><u>Restricted Noxious Weed</u></b>	<b><u>Limitations per Lb. of Seed</u></b>
Blessed Thistle	4 seeds	Cornflower (Ragged Robin)	27 seeds
Cocklebur	4 seeds	Texas Panicum	27 seeds
Spurred Anoda	4 seeds	Bracted Plantain	54 seeds
Velvetleaf	4 seeds	Buckhorn Plantain	54 seeds
Morning-glory	8 seeds	Broadleaf Dock	54 seeds
Corn Cockle	10 seeds	Curly Dock	54 seeds
Wild Radish	12 seeds	Dodder	54 seeds
Purple Nutsedge	27 seeds	Giant Foxtail	54 seeds
Yellow Nutsedge	27 seeds	Horsenettle	54 seeds
Canada Thistle	27 seeds	Quackgrass	54 seeds
Field Bindweed	27 seeds	Wild Mustard	54 seeds
Hedge Bindweed	27 seeds		

Seed of Pensacola Bahiagrass shall not contain more than 7% inert matter, Kentucky Bluegrass, Centipede and Fine or Hard Fescue shall not contain more than 5% inert matter whereas a maximum of 2% inert matter will be allowed on all other kinds of seed. In addition, all seed shall

not contain more than 2% other crop seed nor more than 1% total weed seed. The germination rate as tested by the North Carolina Department of Agriculture shall not fall below 70%, which includes both dormant and hard seed. Seed shall be labeled with not more than 7%, 5% or 2% inert matter (according to above specifications), 2% other crop seed and 1% total weed seed.

Exceptions may be made for minimum pure live seed allowances when cases of seed variety shortages are verified. Pure live seed percentages will be applied in a verified shortage situation. Those purchase orders of deficient seed lots will be credited with the percentage that the seed is deficient.

**FURTHER SPECIFICATIONS FOR EACH SEED GROUP ARE GIVEN BELOW:**

Minimum 85% pure live seed; maximum 1% total weed seed; maximum 2% total other crop seed; maximum 144 restricted noxious weed seed per pound. Seed less than 83% pure live seed will not be approved.

Sericea Lespedeza  
Oats (seeds)

Minimum 80% pure live seed; maximum 1% total weed seed; maximum 2% total other crop; maximum 144 restricted noxious weed seed per pound. Seed less than 78% pure live seed will not be approved.

Tall Fescue (all approved varieties)	Bermudagrass
Kobe Lespedeza	Browntop Millet
Korean Lespedeza	German Millet – Strain R
Weeping Lovegrass	Clover – Red/White/Crimson
Carpetgrass	

Minimum 78% pure live seed; maximum 1% total weed seed; maximum 2% total other crop seed; maximum 144 restricted noxious weed seed per pound. Seed less than 76% pure live seed will not be approved.

Common or Sweet Sundangrass

Minimum 76% pure live seed; maximum 1% total weed seed; maximum 2% total other crop seed; maximum 144 restricted noxious weed seed per pound. Seed less than 74% pure live seed will not be approved.

Rye (grain; all varieties)  
Kentucky Bluegrass (all approved varieties)  
Hard Fescue (all approved varieties)  
Shrub (bicolor) Lespedeza

Minimum 70% pure live seed; maximum 1% total weed seed; maximum 2% total other crop seed; maximum 144 noxious weed seed per pound. Seed less than 70% pure live seed will not be approved.

Centipedegrass	Japanese Millet
Crownvetch	Reed Canary Grass
Pensacola Bahiagrass	Zoysia
Creeping Red Fescue	

Minimum 70% pure live seed; maximum 1% total weed seed; maximum 2% total other crop seed; maximum 5% inert matter; maximum 144 restricted noxious weed seed per pound.

Barnyard Grass  
Big Bluestem  
Little Bluestem  
Bristly Locust  
Birdsfoot Trefoil  
Indiangrass  
Orchardgrass  
Switchgrass  
Yellow Blossom Sweet Clover

**STANDARD SPECIAL PROVISION**

**ERRATA**

(1-16-18)

Z-4

Revise the *2018 Standard Specifications* as follows:

**Division 7**

**Page 7-27, line 4, Article 725-1 MEASUREMENT AND PAYMENT**, replace article number “725-1” with “724-4”.

**Page 7-28, line 10, Article 725-1 MEASUREMENT AND PAYMENT**, replace article number “725-1” with “725-3”.

**STANDARD SPECIAL PROVISION****PLANT AND PEST QUARANTINES****(Imported Fire Ant, Gypsy Moth, Witchweed, Emerald Ash Borer, And Other Noxious Weeds)**

(3-18-03) (Rev. 12-20-16)

Z-04a

**Within Quarantined Area**

This project may be within a county regulated for plant and/or pests. If the project or any part of the Contractor's operations is located within a quarantined area, thoroughly clean all equipment prior to moving out of the quarantined area. Comply with federal/state regulations by obtaining a certificate or limited permit for any regulated article moving from the quarantined area.

**Originating in a Quarantined County**

Obtain a certificate or limited permit issued by the N.C. Department of Agriculture/United States Department of Agriculture. Have the certificate or limited permit accompany the article when it arrives at the project site.

**Contact**

Contact the N.C. Department of Agriculture/United States Department of Agriculture at 1-800-206-9333, 919-707-3730, or <http://www.ncagr.gov/plantindustry/> to determine those specific project sites located in the quarantined area or for any regulated article used on this project originating in a quarantined county.

**Regulated Articles Include**

1. Soil, sand, gravel, compost, peat, humus, muck, and decomposed manure, separately or with other articles. This includes movement of articles listed above that may be associated with cut/waste, ditch pulling, and shoulder cutting.
2. Plants with roots including grass sod.
3. Plant crowns and roots.
4. Bulbs, corms, rhizomes, and tubers of ornamental plants.
5. Hay, straw, fodder, and plant litter of any kind.
6. Clearing and grubbing debris.
7. Used agricultural cultivating and harvesting equipment.
8. Used earth-moving equipment.
9. Any other products, articles, or means of conveyance, of any character, if determined by an inspector to present a hazard of spreading imported fire ant, gypsy moth, witchweed, emerald ash borer, or other noxious weeds.

**STANDARD SPECIAL PROVISION****MINORITY AND FEMALE EMPLOYMENT REQUIREMENTS**

Z-7

**NOTICE OF REQUIREMENTS FOR AFFIRMATIVE ACTION TO ENSURE EQUAL EMPLOYMENT OPPORTUNITY (*EXECUTIVE NUMBER 11246*)**

1. The goals and timetables for minority and female participation, expressed in percentage terms for the Contractor's aggregate workforce in each trade on all construction work in the covered area, see as shown on the attached sheet entitled "Employment Goals for Minority and Female participation".

These goals are applicable to all the Contractor's construction work (whether or not it is Federal or federally assisted) performed in the covered area. If the Contractor performs construction work in a geographical area located outside of the covered area, it shall apply the goals established for such geographical area where the work is actually performed. With regard to this second area, the Contractor also is subject to the goals for both its federally involved and nonfederally involved construction.

The Contractor's compliance with the Executive Order and the regulations in *41 CFR Part 60-4* shall be based on its implementation of the Equal Opportunity Clause, specific affirmative action obligations required by the specifications set forth in *41 CFR 60-4.3(a)*, and its effort to meet the goals. The hours of minority and female employment and training must be substantially uniform throughout the length of the contract, and in each trade and the Contractor shall make a good faith effort to employ minorities and women evenly on each of its projects. The transfer of minority or female employees or trainees from Contractor to Contractor or from project to project for the sole purpose of meeting the Contractor's goals shall be a violation of the contract, the executive Order and the regulations in *41 CFR Part 60-4*. Compliance with the goals will be measured against the total work hours performed.

2. As used in this Notice and in the contract resulting from this solicitation, the "covered area" is the county or counties shown on the cover sheet of the proposal form and contract.

**EMPLOYMENT GOALS FOR MINORITY  
AND FEMALE PARTICIPATION**

Economic Areas

**Area 023 29.7%**

Bertie County  
Camden County  
Chowan County  
Gates County  
Hertford County  
Pasquotank County  
Perquimans County

**Area 024 31.7%**

Beaufort County  
Carteret County  
Craven County  
Dare County  
Edgecombe County  
Green County  
Halifax County  
Hyde County  
Jones County  
Lenoir County  
Martin County  
Nash County  
Northampton County  
Pamlico County  
Pitt County  
Tyrrell County  
Washington County  
Wayne County  
Wilson County

**Area 025 23.5%**

Columbus County  
Duplin County  
Onslow County  
Pender County

**Area 026 33.5%**

Bladen County  
Hoke County  
Richmond County  
Robeson County  
Sampson County  
Scotland County

**Area 027 24.7%**

Chatham County  
Franklin County  
Granville County  
Harnett County  
Johnston County  
Lee County  
Person County  
Vance County  
Warren County

**Area 028 15.5%**

Alleghany County  
Ashe County  
Caswell County  
Davie County  
Montgomery County  
Moore County  
Rockingham County  
Surry County  
Watauga County  
Wilkes County

**Area 029 15.7%**

Alexander County  
Anson County  
Burke County  
Cabarrus County  
Caldwell County  
Catawba County  
Cleveland County  
Iredell County  
Lincoln County  
Polk County  
Rowan County  
Rutherford County  
Stanly County

**Area 0480 8.5%**

Buncombe County  
Madison County

**Area 030 6.3%**

Avery County  
Cherokee County  
Clay County  
Graham County  
Haywood County  
Henderson County  
Jackson County  
McDowell County  
Macon County  
Mitchell County  
Swain County  
Transylvania County  
Yancey County

**SMSA Areas**

**Area 5720 26.6%**  
Currituck County

**Area 9200 20.7%**  
Brunswick County  
New Hanover County

**Area 2560 24.2%**  
Cumberland County

**Area 6640 22.8%**  
Durham County  
Orange County  
Wake County

**Area 1300 16.2%**  
Alamance County

**Area 3120 16.4%**  
Davidson County  
Forsyth County  
Guilford County  
Randolph County  
Stokes County  
Yadkin County

**Area 1520 18.3%**  
Gaston County  
Mecklenburg County  
Union County

---

**Goals for Female**

**Participation in Each Trade**

(Statewide) 6.9%



**STANDARD SPECIAL PROVISION****REQUIRED CONTRACT PROVISIONS FEDERAL - AID CONSTRUCTION CONTRACTS**

FHWA - 1273 Electronic Version - May 1, 2012

Z-8

- I. General
- II. Nondiscrimination
- III. Nonsegregated Facilities
- IV. Davis-Bacon and Related Act Provisions
- V. Contract Work Hours and Safety Standards Act Provisions
- VI. Subletting or Assigning the Contract
- VII. Safety: Accident Prevention
- VIII. False Statements Concerning Highway Projects
- IX. Implementation of Clean Air Act and Federal Water Pollution Control Act
- X. Compliance with Governmentwide Suspension and Debarment Requirements
- XI. Certification Regarding Use of Contract Funds for Lobbying

**ATTACHMENTS**

- A. Employment and Materials Preference for Appalachian Development Highway System or Appalachian Local Access Road Contracts (included in Appalachian contracts only)

**I. GENERAL**

1. Form FHWA-1273 must be physically incorporated in each construction contract funded under Title 23 (excluding emergency contracts solely intended for debris removal). The contractor (or subcontractor) must insert this form in each subcontract and further require its inclusion in all lower tier subcontracts (excluding purchase orders, rental agreements and other agreements for supplies or services).
 

The applicable requirements of Form FHWA-1273 are incorporated by reference for work done under any purchase order, rental agreement or agreement for other services. The prime contractor shall be responsible for compliance by any subcontractor, lower-tier subcontractor or service provider.

Form FHWA-1273 must be included in all Federal-aid design-build contracts, in all subcontracts and in lower tier subcontracts (excluding subcontracts for design services, purchase orders, rental agreements and other agreements for supplies or services). The design-builder shall be responsible for compliance by any subcontractor, lower-tier subcontractor or service provider.

Contracting agencies may reference Form FHWA-1273 in bid proposal or request for proposal documents, however, the Form FHWA-1273 must be physically incorporated (not referenced) in all contracts, subcontracts and lower-tier subcontracts (excluding purchase orders, rental agreements and other agreements for supplies or services related to a construction contract).
2. Subject to the applicability criteria noted in the following sections, these contract provisions shall apply to all work performed on the contract by the contractor's own organization and with the assistance of workers under the contractor's immediate superintendence and to all work performed on the contract by piecework, station work, or by subcontract.
3. A breach of any of the stipulations contained in these Required Contract Provisions may be sufficient grounds for withholding of progress payments, withholding of final payment, termination of the contract, suspension / debarment or any other action determined to be appropriate by the contracting agency and FHWA.
4. Selection of Labor: During the performance of this contract, the contractor shall not use convict labor for any purpose within the limits of a construction project on a Federal-aid highway unless it is labor performed by convicts who are on parole, supervised release, or probation. The term Federal-aid highway does not include roadways functionally classified as local roads or rural minor collectors.

**II. NONDISCRIMINATION**

The provisions of this section related to 23 CFR Part 230 are applicable to all Federal-aid construction contracts and to all related construction subcontracts of \$10,000 or more. The provisions of 23 CFR Part 230 are not applicable to material supply, engineering, or architectural service contracts.

In addition, the contractor and all subcontractors must comply with the following policies: Executive Order 11246, 41 CFR 60, 29 CFR 1625-1627, Title 23 USC Section 140, the Rehabilitation Act of 1973, as amended (29 USC 794), Title VI of the Civil Rights Act of 1964, as amended, and related regulations including 49 CFR Parts 21, 26 and 27; and 23 CFR Parts 200, 230, and 633.

The contractor and all subcontractors must comply with: the requirements of the Equal Opportunity Clause in 41 CFR 60-1.4(b) and, for all construction contracts exceeding \$10,000, the Standard Federal Equal Employment Opportunity Construction Contract Specifications in 41 CFR 60-4.3.

Note: The U.S. Department of Labor has exclusive authority to determine compliance with Executive Order 11246 and the policies of the Secretary of Labor including 41 CFR 60, and 29 CFR 1625-1627. The contracting agency and the FHWA have the authority and the responsibility to ensure compliance with Title 23 USC Section 140, the Rehabilitation Act of 1973, as amended (29 USC 794), and Title VI of the Civil Rights Act of 1964, as amended, and related regulations including 49 CFR Parts 21, 26 and 27; and 23 CFR Parts 200, 230, and 633.

The following provision is adopted from 23 CFR 230, Appendix A, with appropriate revisions to conform to the U.S. Department of Labor (US DOL) and FHWA requirements.

1. **Equal Employment Opportunity:** Equal employment opportunity (EEO) requirements not to discriminate and to take affirmative action to assure equal opportunity as set forth under laws, executive orders, rules, regulations (28 CFR 35, 29 CFR 1630, 29 CFR 1625-1627, 41 CFR 60 and 49 CFR 27) and orders of the Secretary of Labor as modified by the provisions prescribed herein, and imposed pursuant to 23 U.S.C. 140 shall constitute the EEO and specific affirmative action standards for the contractor's project activities under this contract. The provisions of the Americans with Disabilities Act of 1990 (42 U.S.C. 12101 et seq.) set forth under 28 CFR 35 and 29 CFR 1630 are incorporated by reference in this contract. In the execution of this contract, the contractor agrees to comply with the following minimum specific requirement activities of EEO:
  - a. The contractor will work with the contracting agency and the Federal Government to ensure that it has made every good faith effort to provide equal opportunity with respect to all of its terms and conditions of employment and in their review of activities under the contract.
  - b. The contractor will accept as its operating policy the following statement:

"It is the policy of this Company to assure that applicants are employed, and that employees are treated during employment, without regard to their race, religion, sex, color, national origin, age or disability. Such action shall include: employment, upgrading, demotion, or transfer; recruitment or recruitment advertising; layoff or termination; rates of pay or other forms of compensation; and selection for training, including apprenticeship, pre-apprenticeship, and/or on-the-job training."

2. **EEO Officer:** The contractor will designate and make known to the contracting officers an EEO Officer who will have the responsibility for and must be capable of effectively administering and promoting an active EEO program and who must be assigned adequate authority and responsibility to do so.
3. **Dissemination of Policy:** All members of the contractor's staff who are authorized to hire, supervise, promote, and discharge employees, or who recommend such action, or who are substantially involved in such action, will be made fully cognizant of, and will implement, the contractor's EEO policy and contractual responsibilities to provide EEO in each grade and classification of employment. To ensure that the above agreement will be met, the following actions will be taken as a minimum:
  - a. Periodic meetings of supervisory and personnel office employees will be conducted before the start of work and then not less often than once every six months, at which time the contractor's EEO policy and its implementation will be reviewed and explained. The meetings will be conducted by the EEO Officer.
  - b. All new supervisory or personnel office employees will be given a thorough indoctrination by the EEO Officer, covering all major aspects of the contractor's EEO obligations within thirty days following their reporting for duty with the contractor.
  - c. All personnel who are engaged in direct recruitment for the project will be instructed by the EEO Officer in the contractor's procedures for locating and hiring minorities and women.
  - d. Notices and posters setting forth the contractor's EEO policy will be placed in areas readily accessible to employees, applicants for employment and potential employees.
  - e. The contractor's EEO policy and the procedures to implement such policy will be brought to the attention of employees by means of meetings, employee handbooks, or other appropriate means.
4. **Recruitment:** When advertising for employees, the contractor will include in all advertisements for employees the notation: "An Equal Opportunity Employer." All such advertisements will be placed in publications having a large circulation among minorities and women in the area from which the project work force would normally be derived.
  - a. The contractor will, unless precluded by a valid bargaining agreement, conduct systematic and direct recruitment through public and private employee referral sources likely to yield qualified minorities and women. To meet this requirement, the contractor will identify sources of potential minority group employees, and establish with such identified sources whereby minority and women applicants may be referred to the contractor for employment consideration.
  - b. In the event the contractor has a valid bargaining agreement providing for exclusive hiring hall referrals, the contractor is expected to observe the provisions of that agreement to the extent that the system meets the contractor's compliance with EEO contract provisions. Where implementation of such an agreement has the effect of discriminating against minorities or women, or obligates the contractor to do the same, such implementation violates Federal nondiscrimination provisions.
  - c. The contractor will encourage its present employees to refer minorities and women as applicants for employment. Information and procedures with regard to referring such applicants will be discussed with employees.
5. **Personnel Actions:** Wages, working conditions, and employee benefits shall be established and administered, and personnel actions of every type, including hiring, upgrading, promotion, transfer, demotion, layoff, and termination, shall be taken without regard to race, color, religion, sex, national origin, age or disability. The following procedures shall be followed:
  - a. The contractor will conduct periodic inspections of project sites to insure that working conditions and employee facilities do not indicate discriminatory treatment of project site personnel.
  - b. The contractor will periodically evaluate the spread of wages paid within each classification to determine any evidence of discriminatory wage practices.
  - c. The contractor will periodically review selected personnel actions in depth to determine whether there is evidence of discrimination. Where evidence is found, the contractor will promptly take corrective action. If the review indicates that the discrimination may extend beyond the actions reviewed, such corrective action shall include all affected persons.
  - d. The contractor will promptly investigate all complaints of alleged discrimination made to the contractor in connection with its obligations under this contract, will attempt to resolve such complaints, and will take appropriate corrective action within a reasonable time. If the investigation indicates that the discrimination may affect persons other than the complainant, such corrective action shall include such other persons. Upon completion of each investigation, the contractor will inform every complainant of all of their avenues of appeal.
6. **Training and Promotion:**
  - a. The contractor will assist in locating, qualifying, and increasing the skills of minorities and women who are applicants for employment or current employees. Such efforts should be aimed at developing full journey level status employees in the type of trade or job classification involved.
  - b. Consistent with the contractor's work force requirements and as permissible under Federal and State regulations, the contractor shall make full use of training programs, i.e., apprenticeship, and on-the-job training programs for the geographical area of contract performance. In the event a special provision for training is provided under this contract, this subparagraph will be superseded as indicated in the special provision. The contracting agency may reserve training positions for persons who receive welfare assistance in accordance with 23 U.S.C. 140(a).
  - c. The contractor will advise employees and applicants for employment of available training programs and entrance requirements for each.
  - d. The contractor will periodically review the training and promotion potential of employees who are minorities and women and will encourage eligible employees to apply for such training and promotion.
7. **Unions:** If the contractor relies in whole or in part upon unions as a source of employees, the contractor will use good faith efforts to obtain the cooperation of such unions to increase opportunities for minorities and women. Actions by the contractor, either directly or through a contractor's association acting as agent, will include the procedures set forth below:
  - a. The contractor will use good faith efforts to develop, in cooperation with the unions, joint training programs aimed toward qualifying more minorities and women for membership in the unions and increasing the skills of minorities and women so that they may qualify for higher paying employment.
  - b. The contractor will use good faith efforts to incorporate an EEO clause into each union agreement to the end that such union will be contractually bound to refer applicants without regard to their race, color, religion, sex, national origin, age or disability.
  - c. The contractor is to obtain information as to the referral practices and policies of the labor union except that to the extent such information is within the exclusive possession of the labor union and such labor union refuses to furnish such information to the contractor, the contractor shall so certify to the contracting agency and shall set forth what efforts have been made to obtain such information.

- d. In the event the union is unable to provide the contractor with a reasonable flow of referrals within the time limit set forth in the collective bargaining agreement, the contractor will, through independent recruitment efforts, fill the employment vacancies without regard to race, color, religion, sex, national origin, age or disability; making full efforts to obtain qualified and/or qualifiable minorities and women. The failure of a union to provide sufficient referrals (even though it is obligated to provide exclusive referrals under the terms of a collective bargaining agreement) does not relieve the contractor from the requirements of this paragraph. In the event the union referral practice prevents the contractor from meeting the obligations pursuant to Executive Order 11246, as amended, and these special provisions, such contractor shall immediately notify the contracting agency.
8. **Reasonable Accommodation for Applicants / Employees with Disabilities:** The contractor must be familiar with the requirements for and comply with the Americans with Disabilities Act and all rules and regulations established there under. Employers must provide reasonable accommodation in all employment activities unless to do so would cause an undue hardship.
9. **Selection of Subcontractors, Procurement of Materials and Leasing of Equipment:** The contractor shall not discriminate on the grounds of race, color, religion, sex, national origin, age or disability in the selection and retention of subcontractors, including procurement of materials and leases of equipment. The contractor shall take all necessary and reasonable steps to ensure nondiscrimination in the administration of this contract.
- The contractor shall notify all potential subcontractors and suppliers and lessors of their EEO obligations under this contract.
  - The contractor will use good faith efforts to ensure subcontractor compliance with their EEO obligations.
10. **Assurance Required by 49 CFR 26.13(b):**
- The requirements of 49 CFR Part 26 and the State DOT's U.S. DOT-approved DBE program are incorporated by reference.
  - The contractor or subcontractor shall not discriminate on the basis of race, color, national origin, or sex in the performance of this contract. The contractor shall carry out applicable requirements of 49 CFR Part 26 in the award and administration of DOT-assisted contracts. Failure by the contractor to carry out these requirements is a material breach of this contract, which may result in the termination of this contract or such other remedy as the contracting agency deems appropriate.
11. **Records and Reports:** The contractor shall keep such records as necessary to document compliance with the EEO requirements. Such records shall be retained for a period of three years following the date of the final payment to the contractor for all contract work and shall be available at reasonable times and places for inspection by authorized representatives of the contracting agency and the FHWA.
- The records kept by the contractor shall document the following:
    - The number and work hours of minority and non-minority group members and women employed in each work classification on the project;
    - The progress and efforts being made in cooperation with unions, when applicable, to increase employment opportunities for minorities and women; and
    - The progress and efforts being made in locating, hiring, training, qualifying, and upgrading minorities and women;
  - The contractors and subcontractors will submit an annual report to the contracting agency each July for the duration of the project, indicating the number of minority, women, and non-minority group employees currently engaged in each work classification required by the contract work. This information is to be reported on Form FHWA-1391. The staffing data should represent the project work force on board in all or any part of the last payroll period preceding the end of July. If on-the-job training is being required by special provision, the contractor will be required to collect and report training data. The employment data should reflect the work force on board during all or any part of the last payroll period preceding the end of July.

### III. NONSEGREGATED FACILITIES

This provision is applicable to all Federal-aid construction contracts and to all related construction subcontracts of \$10,000 or more.

The contractor must ensure that facilities provided for employees are provided in such a manner that segregation on the basis of race, color, religion, sex, or national origin cannot result. The contractor may neither require such segregated use by written or oral policies nor tolerate such use by employee custom. The contractor's obligation extends further to ensure that its employees are not assigned to perform their services at any location, under the contractor's control, where the facilities are segregated. The term "facilities" includes waiting rooms, work areas, restaurants and other eating areas, time clocks, restrooms, washrooms, locker rooms, and other storage or dressing areas, parking lots, drinking fountains, recreation or entertainment areas, transportation, and housing provided for employees. The contractor shall provide separate or single-user restrooms and necessary dressing or sleeping areas to assure privacy between sexes.

### IV. DAVIS-BACON AND RELATED ACT PROVISIONS

This section is applicable to all Federal-aid construction projects exceeding \$2,000 and to all related subcontracts and lower-tier subcontracts (regardless of subcontract size). The requirements apply to all projects located within the right-of-way of a roadway that is functionally classified as Federal-aid highway. This excludes roadways functionally classified as local roads or rural minor collectors, which are exempt. Contracting agencies may elect to apply these requirements to other projects.

The following provisions are from the U.S. Department of Labor regulations in 29 CFR 5.5 "Contract provisions and related matters" with minor revisions to conform to the FHWA-1273 format and FHWA program requirements.

#### 1. Minimum wages

- All laborers and mechanics employed or working upon the site of the work, will be paid unconditionally and not less often than once a week, and without subsequent deduction or rebate on any account (except such payroll deductions as are permitted by regulations issued by the Secretary of Labor under the Copeland Act (29 CFR part 3)), the full amount of wages and bona fide fringe benefits (or cash equivalents thereof) due at time of payment computed at rates not less than those contained in the wage determination of the Secretary of Labor which is attached hereto and made a part hereof, regardless of any contractual relationship which may be alleged to exist between the contractor and such laborers and mechanics.

Contributions made or costs reasonably anticipated for bona fide fringe benefits under section 1(b)(2) of the Davis-Bacon Act on behalf of laborers or mechanics are considered wages paid to such laborers or mechanics, subject to the provisions of paragraph 1.d. of this section; also, regular contributions made or costs incurred for more than a weekly period (but not less often than quarterly) under plans, funds, or programs which cover the particular weekly period, are deemed to be constructively made or incurred during such weekly period. Such laborers and mechanics shall be paid the appropriate wage rate and fringe benefits on the wage determination for the classification of work actually performed, without regard to skill, except as provided in 29 CFR 5.5(a)(4). Laborers or mechanics performing work in more than one classification may be compensated at the rate specified for each classification for the time actually worked therein: Provided, That the employer's payroll records accurately set forth the time spent in each classification in which work is performed. The wage determination (including any additional classification and wage rates conformed under paragraph 1.b. of this section) and the Davis-Bacon poster (WH-1321) shall be posted at all times by the contractor and its subcontractors at the site of the work in a prominent and accessible place where it can be easily seen by the workers.

- b. (1) The contracting officer shall require that any class of laborers or mechanics, including helpers, which is not listed in the wage determination and which is to be employed under the contract shall be classified in conformance with the wage determination. The contracting officer shall approve an additional classification and wage rate and fringe benefits therefore only when the following criteria have been met:
  - (i) The work to be performed by the classification requested is not performed by a classification in the wage determination; and
  - (ii) The classification is utilized in the area by the construction industry; and
  - (iii) The proposed wage rate, including any bona fide fringe benefits, bears a reasonable relationship to the wage rates contained in the wage determination.
- (2) If the contractor and the laborers and mechanics to be employed in the classification (if known), or their representatives, and the contracting officer agree on the classification and wage rate (including the amount designated for fringe benefits where appropriate), a report of the action taken shall be sent by the contracting officer to the Administrator of the Wage and Hour Division, Employment Standards Administration, U.S. Department of Labor, Washington, DC 20210. The Administrator, or an authorized representative, will approve, modify, or disapprove every additional classification action within 30 days of receipt and so advise the contracting officer or will notify the contracting officer within the 30-day period that additional time is necessary.
- (3) In the event the contractor, the laborers or mechanics to be employed in the classification or their representatives, and the contracting officer do not agree on the proposed classification and wage rate (including the amount designated for fringe benefits, where appropriate), the contracting officer shall refer the questions, including the views of all interested parties and the recommendation of the contracting officer, to the Wage and Hour Administrator for determination. The Wage and Hour Administrator, or an authorized representative, will issue a determination within 30 days of receipt and so advise the contracting officer or will notify the contracting officer within the 30-day period that additional time is necessary.
- (4) The wage rate (including fringe benefits where appropriate) determined pursuant to paragraphs 1.b.(2) or 1.b.(3) of this section, shall be paid to all workers performing work in the classification under this contract from the first day on which work is performed in the classification.
- c. Whenever the minimum wage rate prescribed in the contract for a class of laborers or mechanics includes a fringe benefit which is not expressed as an hourly rate, the contractor shall either pay the benefit as stated in the wage determination or shall pay another bona fide fringe benefit or an hourly cash equivalent thereof.
- d. If the contractor does not make payments to a trustee or other third person, the contractor may consider as part of the wages of any laborer or mechanic the amount of any costs reasonably anticipated in providing bona fide fringe benefits under a plan or program. Provided, That the Secretary of Labor has found, upon the written request of the contractor, that the applicable standards of the Davis-Bacon Act have been met. The Secretary of Labor may require the contractor to set aside in a separate account assets for the meeting of obligations under the plan or program.
2. **Withholding.** The contracting agency shall upon its own action or upon written request of an authorized representative of the Department of Labor, withhold or cause to be withheld from the contractor under this contract, or any other Federal contract with the same prime contractor, or any other federally-assisted contract subject to Davis-Bacon prevailing wage requirements, which is held by the same prime contractor, so much of the accrued payments or advances as may be considered necessary to pay laborers and mechanics, including apprentices, trainees, and helpers, employed by the contractor or any subcontractor the full amount of wages required by the contract. In the event of failure to pay any laborer or mechanic, including any apprentice, trainee, or helper, employed or working on the site of the work, all or part of the wages required by the contract, the contracting agency may, after written notice to the contractor, take such action as may be necessary to cause the suspension of any further payment, advance, or guarantee of funds until such violations have ceased.
3. **Payrolls and basic records**
  - a. Payrolls and basic records relating thereto shall be maintained by the contractor during the course of the work and preserved for a period of three years thereafter for all laborers and mechanics working at the site of the work. Such records shall contain the name, address, and social security number of each such worker, his or her correct classification, hourly rates of wages paid (including rates of contributions or costs anticipated for bona fide fringe benefits or cash equivalents thereof of the types described in section 1(b)(2)(B) of the Davis-Bacon Act), daily and weekly number of hours worked, deductions made and actual wages paid. Whenever the Secretary of Labor has found under 29 CFR 5.5(a)(1)(iv) that the wages of any laborer or mechanic include the amount of any costs reasonably anticipated in providing benefits under a plan or program described in section 1(b)(2)(B) of the Davis-Bacon Act, the contractor shall maintain records which show that the commitment to provide such benefits is enforceable, that the plan or program is financially responsible, and that the plan or program has been communicated in writing to the laborers or mechanics affected, and records which show the costs anticipated or the actual cost incurred in providing such benefits. Contractors employing apprentices or trainees under approved programs shall maintain written evidence of the registration of apprenticeship programs and certification of trainee programs, the registration of the apprentices and trainees, and the ratios and wage rates prescribed in the applicable programs.
  - b. (1) The contractor shall submit weekly for each week in which any contract work is performed a copy of all payrolls to the contracting agency. The payrolls submitted shall set out accurately and completely all of the information required to be maintained under 29 CFR 5.5(a)(3)(i), except that full social security numbers and home addresses shall not be included on weekly transmittals. Instead the payrolls shall only need to include an individually identifying number for each employee ( e.g. , the last four digits of the employee's social security number). The required weekly payroll information may be submitted in any form desired. Optional Form WH-347 is available for this purpose from the Wage and Hour Division Web site at <http://www.dol.gov/esa/whd/forms/wh347instr.htm> or its successor site. The prime contractor is responsible for the submission of copies of payrolls by all subcontractors. Contractors and subcontractors shall maintain the full social security number and current address of each covered worker, and shall provide them upon request to the contracting agency for transmission to the State DOT, the FHWA or the Wage and Hour Division of the Department of Labor for purposes of an investigation or audit of compliance with prevailing wage requirements. It is not a violation of this section for a prime contractor to require a subcontractor to provide addresses and social security numbers to the prime contractor for its own records, without weekly submission to the contracting agency.
  - (2) Each payroll submitted shall be accompanied by a "Statement of Compliance," signed by the contractor or subcontractor or his or her agent who pays or supervises the payment of the persons employed under the contract and shall certify the following:
    - (i) That the payroll for the payroll period contains the information required to be provided under §5.5 (a)(3)(ii) of Regulations, 29 CFR part 5, the appropriate information is being maintained under §5.5 (a)(3)(i) of Regulations, 29 CFR part 5, and that such information is correct and complete;
    - (ii) That each laborer or mechanic (including each helper, apprentice, and trainee) employed on the contract during the payroll period has been paid the full weekly wages earned, without rebate, either directly or indirectly, and that no deductions have been made either directly or indirectly from the full wages earned, other than permissible deductions as set forth in Regulations, 29 CFR part 3;
    - (iii) That each laborer or mechanic has been paid not less than the applicable wage rates and fringe benefits or cash equivalents for the classification of work performed, as specified in the applicable wage determination incorporated into the contract.

- (3) The weekly submission of a properly executed certification set forth on the reverse side of Optional Form WH-347 shall satisfy the requirement for submission of the "Statement of Compliance" required by paragraph 3.b.(2) of this section.
- (4) The falsification of any of the above certifications may subject the contractor or subcontractor to civil or criminal prosecution under section 1001 of title 18 and section 231 of title 31 of the United States Code.
- c. The contractor or subcontractor shall make the records required under paragraph 3.a. of this section available for inspection, copying, or transcription by authorized representatives of the contracting agency, the State DOT, the FHWA, or the Department of Labor, and shall permit such representatives to interview employees during working hours on the job. If the contractor or subcontractor fails to submit the required records or to make them available, the FHWA may, after written notice to the contractor, the contracting agency or the State DOT, take such action as may be necessary to cause the suspension of any further payment, advance, or guarantee of funds. Furthermore, failure to submit the required records upon request or to make such records available may be grounds for debarment action pursuant to 29 CFR 5.12.
4. **Apprentices and trainees**
- a. Apprentices (programs of the USDOL). Apprentices will be permitted to work at less than the predetermined rate for the work they performed when they are employed pursuant to and individually registered in a bona fide apprenticeship program registered with the U.S. Department of Labor, Employment and Training Administration, Office of Apprenticeship Training, Employer and Labor Services, or with a State Apprenticeship Agency recognized by the Office, or if a person is employed in his or her first 90 days of probationary employment as an apprentice in such an apprenticeship program, who is not individually registered in the program, but who has been certified by the Office of Apprenticeship Training, Employer and Labor Services or a State Apprenticeship Agency (where appropriate) to be eligible for probationary employment as an apprentice.
- The allowable ratio of apprentices to journeymen on the job site in any craft classification shall not be greater than the ratio permitted to the contractor as to the entire work force under the registered program. Any worker listed on a payroll at an apprentice wage rate, who is not registered or otherwise employed as stated above, shall be paid not less than the applicable wage rate on the wage determination for the classification of work actually performed. In addition, any apprentice performing work on the job site in excess of the ratio permitted under the registered program shall be paid not less than the applicable wage rate on the wage determination for the work actually performed. Where a contractor is performing construction on a project in a locality other than that in which its program is registered, the ratios and wage rates (expressed in percentages of the journeyman's hourly rate) specified in the contractor's or subcontractor's registered program shall be observed.
- Every apprentice must be paid at not less than the rate specified in the registered program for the apprentice's level of progress, expressed as a percentage of the journeymen hourly rate specified in the applicable wage determination. Apprentices shall be paid fringe benefits in accordance with the provisions of the apprenticeship program. If the apprenticeship program does not specify fringe benefits, apprentices must be paid the full amount of fringe benefits listed on the wage determination for the applicable classification. If the Administrator determines that a different practice prevails for the applicable apprentice classification, fringes shall be paid in accordance with that determination.
- In the event the Office of Apprenticeship Training, Employer and Labor Services, or a State Apprenticeship Agency recognized by the Office, withdraws approval of an apprenticeship program, the contractor will no longer be permitted to utilize apprentices at less than the applicable predetermined rate for the work performed until an acceptable program is approved.
- b. Trainees (programs of the USDOL). Except as provided in 29 CFR 5.16, trainees will not be permitted to work at less than the predetermined rate for the work performed unless they are employed pursuant to and individually registered in a program which has received prior approval, evidenced by formal certification by the U.S. Department of Labor, Employment and Training Administration.
- The ratio of trainees to journeymen on the job site shall not be greater than permitted under the plan approved by the Employment and Training Administration.
- Every trainee must be paid at not less than the rate specified in the approved program for the trainee's level of progress, expressed as a percentage of the journeyman hourly rate specified in the applicable wage determination. Trainees shall be paid fringe benefits in accordance with the provisions of the trainee program. If the trainee program does not mention fringe benefits, trainees shall be paid the full amount of fringe benefits listed on the wage determination unless the Administrator of the Wage and Hour Division determines that there is an apprenticeship program associated with the corresponding journeyman wage rate on the wage determination which provides for less than full fringe benefits for apprentices. Any employee listed on the payroll at a trainee rate who is not registered and participating in a training plan approved by the Employment and Training Administration shall be paid not less than the applicable wage rate on the wage determination for the classification of work actually performed. In addition, any trainee performing work on the job site in excess of the ratio permitted under the registered program shall be paid not less than the applicable wage rate on the wage determination for the work actually performed.
- In the event the Employment and Training Administration withdraws approval of a training program, the contractor will no longer be permitted to utilize trainees at less than the applicable predetermined rate for the work performed until an acceptable program is approved.
- c. Equal employment opportunity. The utilization of apprentices, trainees and journeymen under this part shall be in conformity with the equal employment opportunity requirements of Executive Order 11246, as amended, and 29 CFR part 30.
- d. Apprentices and Trainees (programs of the U.S. DOT). Apprentices and trainees working under apprenticeship and skill training programs which have been certified by the Secretary of Transportation as promoting EEO in connection with Federal-aid highway construction programs are not subject to the requirements of paragraph 4 of this Section IV. The straight time hourly wage rates for apprentices and trainees under such programs will be established by the particular programs. The ratio of apprentices and trainees to journeymen shall not be greater than permitted by the terms of the particular program.
5. **Compliance with Copeland Act requirements.** The contractor shall comply with the requirements of 29 CFR part 3, which are incorporated by reference in this contract.
6. **Subcontracts.** The contractor or subcontractor shall insert Form FHWA-1273 in any subcontracts and also require the subcontractors to include Form FHWA-1273 in any lower tier subcontracts. The prime contractor shall be responsible for the compliance by any subcontractor or lower tier subcontractor with all the contract clauses in 29 CFR 5.5.
7. **Contract termination:** debarment. A breach of the contract clauses in 29 CFR 5.5 may be grounds for termination of the contract, and for debarment as a contractor and a subcontractor as provided in 29 CFR 5.12.
8. **Compliance with Davis-Bacon and Related Act requirements.** All rulings and interpretations of the Davis-Bacon and Related Acts contained in 29 CFR parts 1, 3, and 5 are herein incorporated by reference in this contract.
9. **Disputes concerning labor standards.** Disputes arising out of the labor standards provisions of this contract shall not be subject to the general disputes clause of this contract. Such disputes shall be resolved in accordance with the procedures of the Department of Labor set forth in 29 CFR parts 5, 6, and 7. Disputes within the meaning of this clause include disputes between the contractor (or any of its subcontractors) and the contracting agency, the U.S. Department of Labor, or the employees or their representatives.
10. **Certification of eligibility.**
- a. By entering into this contract, the contractor certifies that neither it (nor he or she) nor any person or firm who has an interest in the contractor's firm is a person or firm ineligible to be awarded Government contracts by virtue of section 3(a) of the Davis-Bacon Act or 29 CFR 5.12(a)(1).

- b. No part of this contract shall be subcontracted to any person or firm ineligible for award of a Government contract by virtue of section 3(a) of the Davis-Bacon Act or 29 CFR 5.12(a)(1).
- c. The penalty for making false statements is prescribed in the U.S. Criminal Code, 18 U.S.C. 1001.

#### V. CONTRACT WORK HOURS AND SAFETY STANDARDS ACT

The following clauses apply to any Federal-aid construction contract in an amount in excess of \$100,000 and subject to the overtime provisions of the Contract Work Hours and Safety Standards Act. These clauses shall be inserted in addition to the clauses required by 29 CFR 5.5(a) or 29 CFR 4.6. As used in this paragraph, the terms laborers and mechanics include watchmen and guards.

1. **Overtime requirements.** No contractor or subcontractor contracting for any part of the contract work which may require or involve the employment of laborers or mechanics shall require or permit any such laborer or mechanic in any workweek in which he or she is employed on such work to work in excess of forty hours in such workweek unless such laborer or mechanic receives compensation at a rate not less than one and one-half times the basic rate of pay for all hours worked in excess of forty hours in such workweek.
2. **Violation; liability for unpaid wages; liquidated damages.** In the event of any violation of the clause set forth in paragraph (1.) of this section, the contractor and any subcontractor responsible therefor shall be liable for the unpaid wages. In addition, such contractor and subcontractor shall be liable to the United States (in the case of work done under contract for the District of Columbia or a territory, to such District or to such territory), for liquidated damages. Such liquidated damages shall be computed with respect to each individual laborer or mechanic, including watchmen and guards, employed in violation of the clause set forth in paragraph (1.) of this section, in the sum of \$10 for each calendar day on which such individual was required or permitted to work in excess of the standard workweek of forty hours without payment of the overtime wages required by the clause set forth in paragraph (1.) of this section.
3. **Withholding for unpaid wages and liquidated damages.** The FHWA or the contacting agency shall upon its own action or upon written request of an authorized representative of the Department of Labor withhold or cause to be withheld, from any moneys payable on account of work performed by the contractor or subcontractor under any such contract or any other Federal contract with the same prime contractor, or any other federally-assisted contract subject to the Contract Work Hours and Safety Standards Act, which is held by the same prime contractor, such sums as may be determined to be necessary to satisfy any liabilities of such contractor or subcontractor for unpaid wages and liquidated damages as provided in the clause set forth in paragraph (2.) of this section.
4. **Subcontracts.** The contractor or subcontractor shall insert in any subcontracts the clauses set forth in paragraph (1.) through (4.) of this section and also a clause requiring the subcontractors to include these clauses in any lower tier subcontracts. The prime contractor shall be responsible for compliance by any subcontractor or lower tier subcontractor with the clauses set forth in paragraphs (1.) through (4.) of this section.

#### VI. SUBLETTING OR ASSIGNING THE CONTRACT

This provision is applicable to all Federal-aid construction contracts on the National Highway System.

1. The contractor shall perform with its own organization contract work amounting to not less than 30 percent (or a greater percentage if specified elsewhere in the contract) of the total original contract price, excluding any specialty items designated by the contracting agency. Specialty items may be performed by subcontract and the amount of any such specialty items performed may be deducted from the total original contract price before computing the amount of work required to be performed by the contractor's own organization (23 CFR 635.116).
  - a. The term "perform work with its own organization" refers to workers employed or leased by the prime contractor, and equipment owned or rented by the prime contractor, with or without operators. Such term does not include employees or equipment of a subcontractor or lower tier subcontractor, agents of the prime contractor, or any other assignees. The term may include payments for the costs of hiring leased employees

from an employee leasing firm meeting all relevant Federal and State regulatory requirements. Leased employees may only be included in this term if the prime contractor meets all of the following conditions:

- (1) the prime contractor maintains control over the supervision of the day-to-day activities of the leased employees;
  - (2) the prime contractor remains responsible for the quality of the work of the leased employees;
  - (3) the prime contractor retains all power to accept or exclude individual employees from work on the project; and
  - (4) the prime contractor remains ultimately responsible for the payment of predetermined minimum wages, the submission of payrolls, statements of compliance and all other Federal regulatory requirements.
- b. "Specialty Items" shall be construed to be limited to work that requires highly specialized knowledge, abilities, or equipment not ordinarily available in the type of contracting organizations qualified and expected to bid or propose on the contract as a whole and in general are to be limited to minor components of the overall contract.
2. The contract amount upon which the requirements set forth in paragraph (1) of Section VI is computed includes the cost of material and manufactured products which are to be purchased or produced by the contractor under the contract provisions.
  3. The contractor shall furnish (a) a competent superintendent or supervisor who is employed by the firm, has full authority to direct performance of the work in accordance with the contract requirements, and is in charge of all construction operations (regardless of who performs the work) and (b) such other of its own organizational resources (supervision, management, and engineering services) as the contracting officer determines is necessary to assure the performance of the contract.
  4. No portion of the contract shall be sublet, assigned or otherwise disposed of except with the written consent of the contracting officer, or authorized representative, and such consent when given shall not be construed to relieve the contractor of any responsibility for the fulfillment of the contract. Written consent will be given only after the contracting agency has assured that each subcontract is evidenced in writing and that it contains all pertinent provisions and requirements of the prime contract.
  5. The 30% self-performance requirement of paragraph (1) is not applicable to design-build contracts; however, contracting agencies may establish their own self-performance requirements.

#### **VII. SAFETY: ACCIDENT PREVENTION**

This provision is applicable to all Federal-aid construction contracts and to all related subcontracts.

1. In the performance of this contract the contractor shall comply with all applicable Federal, State, and local laws governing safety, health, and sanitation (23 CFR 635). The contractor shall provide all safeguards, safety devices and protective equipment and take any other needed actions as it determines, or as the contracting officer may determine, to be reasonably necessary to protect the life and health of employees on the job and the safety of the public and to protect property in connection with the performance of the work covered by the contract.
2. It is a condition of this contract, and shall be made a condition of each subcontract, which the contractor enters into pursuant to this contract, that the contractor and any subcontractor shall not permit any employee, in performance of the contract, to work in surroundings or under conditions which are unsanitary, hazardous or dangerous to his/her health or safety, as determined under construction safety and health standards (29 CFR 1926) promulgated by the Secretary of Labor, in accordance with Section 107 of the Contract Work Hours and Safety Standards Act (40 U.S.C. 3704).
3. Pursuant to 29 CFR 1926.3, it is a condition of this contract that the Secretary of Labor or authorized representative thereof, shall have right of entry to any site of contract performance to inspect or investigate the matter of compliance with the construction safety and health standards and to carry out the duties of the Secretary under Section 107 of the Contract Work Hours and Safety Standards Act (40 U.S.C.3704).

#### **VIII. FALSE STATEMENTS CONCERNING HIGHWAY PROJECTS**

This provision is applicable to all Federal-aid construction contracts and to all related subcontracts.

In order to assure high quality and durable construction in conformity with approved plans and specifications and a high degree of reliability on statements and representations made by engineers, contractors, suppliers, and workers on Federal-aid highway projects, it is essential that all persons concerned with the project perform their functions as carefully, thoroughly, and honestly as possible. Willful falsification, distortion, or misrepresentation with respect to any facts related to the project is a violation of Federal law. To prevent any misunderstanding regarding the seriousness of these and similar acts, Form FHWA-1022 shall be posted on each Federal-aid highway project (23 CFR 635) in one or more places where it is readily available to all persons concerned with the project:

18 U.S.C. 1020 reads as follows:

"Whoever, being an officer, agent, or employee of the United States, or of any State or Territory, or whoever, whether a person, association, firm, or corporation, knowingly makes any false statement, false representation, or false report as to the character, quality, quantity, or cost of the material used or to be used, or the quantity or quality of the work performed or to be performed, or the cost thereof in connection with the submission of plans, maps, specifications, contracts, or costs of construction on any highway or related project submitted for approval to the Secretary of Transportation; or

Whoever knowingly makes any false statement, false representation, false report or false claim with respect to the character, quality, quantity, or cost of any work performed or to be performed, or materials furnished or to be furnished, in connection with the construction of any highway or related project approved by the Secretary of Transportation; or

Whoever knowingly makes any false statement or false representation as to material fact in any statement, certificate, or report submitted pursuant to provisions of the Federal-aid Roads Act approved July 1, 1916, (39 Stat. 355), as amended and supplemented;

Shall be fined under this title or imprisoned not more than 5 years or both."

#### **IX. IMPLEMENTATION OF CLEAN AIR ACT AND FEDERAL WATER POLLUTION CONTROL ACT**

This provision is applicable to all Federal-aid construction contracts and to all related subcontracts.

By submission of this bid/proposal or the execution of this contract, or subcontract, as appropriate, the bidder, proposer, Federal-aid construction contractor, or subcontractor, as appropriate, will be deemed to have stipulated as follows:

1. That any person who is or will be utilized in the performance of this contract is not prohibited from receiving an award due to a violation of Section 508 of the Clean Water Act or Section 306 of the Clean Air Act.
2. That the contractor agrees to include or cause to be included the requirements of paragraph (1) of this Section X in every subcontract, and further agrees to take such action as the contracting agency may direct as a means of enforcing such requirements.

#### **X. CERTIFICATION REGARDING DEBARMENT, SUSPENSION, INELIGIBILITY AND VOLUNTARY EXCLUSION**

This provision is applicable to all Federal-aid construction contracts, design-build contracts, subcontracts, lower-tier subcontracts, purchase orders, lease agreements, consultant contracts or any other covered transaction requiring FHWA approval or that is estimated to cost \$25,000 or more – as defined in 2 CFR Parts 180 and 1200.

**1. Instructions for Certification – First Tier Participants:**

- a. By signing and submitting this proposal, the prospective first tier participant is providing the certification set out below.
- b. The inability of a person to provide the certification set out below will not necessarily result in denial of participation in this covered transaction. The prospective first tier participant shall submit an explanation of why it cannot provide the certification set out below. The certification or explanation will be considered in connection with the department or agency's determination whether to enter into this transaction. However, failure of the prospective first tier participant to furnish a certification or an explanation shall disqualify such a person from participation in this transaction.
- c. The certification in this clause is a material representation of fact upon which reliance was placed when the contracting agency determined to enter into this transaction. If it is later determined that the prospective participant knowingly rendered an erroneous certification, in addition to other remedies available to the Federal Government, the contracting agency may terminate this transaction for cause of default.
- d. The prospective first tier participant shall provide immediate written notice to the contracting agency to whom this proposal is submitted if any time the prospective first tier participant learns that its certification was erroneous when submitted or has become erroneous by reason of changed circumstances.
- e. The terms "covered transaction," "debarred," "suspended," "ineligible," "participant," "person," "principal," and "voluntarily excluded," as used in this clause, are defined in 2 CFR Parts 180 and 1200. "First Tier Covered Transactions" refers to any covered transaction between a grantee or subgrantee of Federal funds and a participant (such as the prime or general contract). "Lower Tier Covered Transactions" refers to any covered transaction under a First Tier Covered Transaction (such as subcontracts). "First Tier Participant" refers to the participant who has entered into a covered transaction with a grantee or subgrantee of Federal funds (such as the prime or general contractor). "Lower Tier Participant" refers any participant who has entered into a covered transaction with a First Tier Participant or other Lower Tier Participants (such as subcontractors and suppliers).
- f. The prospective first tier participant agrees by submitting this proposal that, should the proposed covered transaction be entered into, it shall not knowingly enter into any lower tier covered transaction with a person who is debarred, suspended, declared ineligible, or voluntarily excluded from participation in this covered transaction, unless authorized by the department or agency entering into this transaction.
- g. The prospective first tier participant further agrees by submitting this proposal that it will include the clause titled "Certification Regarding Debarment, Suspension, Ineligibility and Voluntary Exclusion-Lower Tier Covered Transactions," provided by the department or contracting agency, entering into this covered transaction, without modification, in all lower tier covered transactions and in all solicitations for lower tier covered transactions exceeding the \$25,000 threshold.
- h. A participant in a covered transaction may rely upon a certification of a prospective participant in a lower tier covered transaction that is not debarred, suspended, ineligible, or voluntarily excluded from the covered transaction, unless it knows that the certification is erroneous. A participant is responsible for ensuring that its principals are not suspended, debarred, or otherwise ineligible to participate in covered transactions. To verify the eligibility of its principals, as well as the eligibility of any lower tier prospective participants, each participant may, but is not required to, check the Excluded Parties List System website (<https://www.epls.gov/>), which is compiled by the General Services Administration.
- i. Nothing contained in the foregoing shall be construed to require the establishment of a system of records in order to render in good faith the certification required by this clause. The knowledge and information of the prospective participant is not required to exceed that which is normally possessed by a prudent person in the ordinary course of business dealings.
- j. Except for transactions authorized under paragraph (f) of these instructions, if a participant in a covered transaction knowingly enters into a lower tier covered transaction with a person who is suspended, debarred, ineligible, or voluntarily excluded from participation in this transaction, in addition to other remedies available to the Federal Government, the department or agency may terminate this transaction for cause or default.

\* \* \* \* \*

**2. Certification Regarding Debarment, Suspension, Ineligibility and Voluntary Exclusion – First Tier Participants:**

- a. The prospective first tier participant certifies to the best of its knowledge and belief, that it and its principals:
  - (1) Are not presently debarred, suspended, proposed for debarment, declared ineligible, or voluntarily excluded from participating in covered transactions by any Federal department or agency;
  - (2) Have not within a three-year period preceding this proposal been convicted of or had a civil judgment rendered against them for commission of fraud or a criminal offense in connection with obtaining, attempting to obtain, or performing a public (Federal, State or local) transaction or contract under a public transaction; violation of Federal or State antitrust statutes or commission of embezzlement, theft, forgery, bribery, falsification or destruction of records, making false statements, or receiving stolen property;
  - (3) Are not presently indicted for or otherwise criminally or civilly charged by a governmental entity (Federal, State or local) with commission of any of the offenses enumerated in paragraph (a)(2) of this certification; and
  - (4) Have not within a three-year period preceding this application/proposal had one or more public transactions (Federal, State or local) terminated for cause or default.
- b. Where the prospective participant is unable to certify to any of the statements in this certification, such prospective participant shall attach an explanation to this proposal.

**2. Instructions for Certification - Lower Tier Participants:**

(Applicable to all subcontracts, purchase orders and other lower tier transactions requiring prior FHWA approval or estimated to cost \$25,000 or more - 2 CFR Parts 180 and 1200)

- a. By signing and submitting this proposal, the prospective lower tier is providing the certification set out below.
- b. The certification in this clause is a material representation of fact upon which reliance was placed when this transaction was entered into. If it is later determined that the prospective lower tier participant knowingly rendered an erroneous certification, in addition to other remedies available to the Federal Government, the department, or agency with which this transaction originated may pursue available remedies, including suspension and/or debarment.
- c. The prospective lower tier participant shall provide immediate written notice to the person to which this proposal is submitted if at any time the prospective lower tier participant learns that its certification was erroneous by reason of changed circumstances.
- d. The terms "covered transaction," "debarred," "suspended," "ineligible," "participant," "person," "principal," and "voluntarily excluded," as used in this clause, are defined in 2 CFR Parts 180 and 1200. You may contact the person to which this proposal is submitted for assistance in obtaining a copy of those regulations. "First Tier Covered Transactions" refers to any covered transaction between a grantee or subgrantee of



Federal funds and a participant (such as the prime or general contract). "Lower Tier Covered Transactions" refers to any covered transaction under a First Tier Covered Transaction (such as subcontracts). "First Tier Participant" refers to the participant who has entered into a covered transaction with a grantee or subgrantee of Federal funds (such as the prime or general contractor). "Lower Tier Participant" refers to any participant who has entered into a covered transaction with a First Tier Participant or other Lower Tier Participants (such as subcontractors and suppliers).

- e. The prospective lower tier participant agrees by submitting this proposal that, should the proposed covered transaction be entered into, it shall not knowingly enter into any lower tier covered transaction with a person who is debarred, suspended, declared ineligible, or voluntarily excluded from participation in this covered transaction, unless authorized by the department or agency with which this transaction originated.
- f. The prospective lower tier participant further agrees by submitting this proposal that it will include this clause titled "Certification Regarding Debarment, Suspension, Ineligibility and Voluntary Exclusion-Lower Tier Covered Transaction," without modification, in all lower tier covered transactions and in all solicitations for lower tier covered transactions exceeding the \$25,000 threshold.
- g. A participant in a covered transaction may rely upon a certification of a prospective participant in a lower tier covered transaction that is not debarred, suspended, ineligible, or voluntarily excluded from the covered transaction, unless it knows that the certification is erroneous. A participant is responsible for ensuring that its principals are not suspended, debarred, or otherwise ineligible to participate in covered transactions. To verify the eligibility of its principals, as well as the eligibility of any lower tier prospective participants, each participant may, but is not required to, check the Excluded Parties List System website (<https://www.epls.gov/>), which is compiled by the General Services Administration.
- h. Nothing contained in the foregoing shall be construed to require establishment of a system of records in order to render in good faith the certification required by this clause. The knowledge and information of participant is not required to exceed that which is normally possessed by a prudent person in the ordinary course of business dealings.
- i. Except for transactions authorized under paragraph e of these instructions, if a participant in a covered transaction knowingly enters into a lower tier covered transaction with a person who is suspended, debarred, ineligible, or voluntarily excluded from participation in this transaction, in addition to other remedies available to the Federal Government, the department or agency with which this transaction originated may pursue available remedies, including suspension and/or debarment.

\* \* \* \* \*

**Certification Regarding Debarment, Suspension, Ineligibility and Voluntary Exclusion--Lower Tier Participants:**

1. The prospective lower tier participant certifies, by submission of this proposal, that neither it nor its principals is presently debarred, suspended, proposed for debarment, declared ineligible, or voluntarily excluded from participating in covered transactions by any Federal department or agency.
2. Where the prospective lower tier participant is unable to certify to any of the statements in this certification, such prospective participant shall attach an explanation to this proposal.

\* \* \* \* \*

**XI. CERTIFICATION REGARDING USE OF CONTRACT FUNDS FOR LOBBYING**

This provision is applicable to all Federal-aid construction contracts and to all related subcontracts which exceed \$100,000 (49 CFR 20).

1. The prospective participant certifies, by signing and submitting this bid or proposal, to the best of his or her knowledge and belief, that:
  - a. No Federal appropriated funds have been paid or will be paid, by or on behalf of the undersigned, to any person for influencing or attempting to influence an officer or employee of any Federal agency, a Member of Congress, an officer or employee of Congress, or an employee of a Member of Congress in connection with the awarding of any Federal contract, the making of any Federal grant, the making of any Federal loan, the entering into of any cooperative agreement, and the extension, continuation, renewal, amendment, or modification of any Federal contract, grant, loan, or cooperative agreement.
  - b. If any funds other than Federal appropriated funds have been paid or will be paid to any person for influencing or attempting to influence an officer or employee of any Federal agency, a Member of Congress, an officer or employee of Congress, or an employee of a Member of Congress in connection with this Federal contract, grant, loan, or cooperative agreement, the undersigned shall complete and submit Standard Form-LLL, "Disclosure Form to Report Lobbying," in accordance with its instructions.
2. This certification is a material representation of fact upon which reliance was placed when this transaction was made or entered into. Submission of this certification is a prerequisite for making or entering into this transaction imposed by 31 U.S.C. 1352. Any person who fails to file the required certification shall be subject to a civil penalty of not less than \$10,000 and not more than \$100,000 for each such failure.
3. The prospective participant also agrees by submitting its bid or proposal that the participant shall require that the language of this certification be included in all lower tier subcontracts, which exceed \$100,000 and that all such recipients shall certify and disclose accordingly.

**STANDARD SPECIAL PROVISION****ON-THE-JOB TRAINING**

(10-16-07) (Rev. 4-21-15)

Z-10

**Description**

The North Carolina Department of Transportation will administer a custom version of the Federal On-the-Job Training (OJT) Program, commonly referred to as the Alternate OJT Program. All contractors (existing and newcomers) will be automatically placed in the Alternate Program. Standard OJT requirements typically associated with individual projects will no longer be applied at the project level. Instead, these requirements will be applicable on an annual basis for each contractor administered by the OJT Program Manager.

On the Job Training shall meet the requirements of 23 CFR 230.107 (b), 23 USC – Section 140, this provision and the On-the-Job Training Program Manual.

The Alternate OJT Program will allow a contractor to train employees on Federal, State and privately funded projects located in North Carolina. However, priority shall be given to training employees on NCDOT Federal-Aid funded projects.

**Minorities and Women**

Developing, training and upgrading of minorities and women toward journeyman level status is a primary objective of this special training provision. Accordingly, the Contractor shall make every effort to enroll minority and women as trainees to the extent that such persons are available within a reasonable area of recruitment. This training commitment is not intended, and shall not be used, to discriminate against any applicant for training, whether a member of a minority group or not.

**Assigning Training Goals**

The Department, through the OJT Program Manager, will assign training goals for a calendar year based on the contractors' past three years' activity and the contractors' anticipated upcoming year's activity with the Department. At the beginning of each year, all contractors eligible will be contacted by the Department to determine the number of trainees that will be assigned for the upcoming calendar year. At that time the Contractor shall enter into an agreement with the Department to provide a self-imposed on-the-job training program for the calendar year. This agreement will include a specific number of annual training goals agreed to by both parties. The number of training assignments may range from 1 to 15 per contractor per calendar year. The Contractor shall sign an agreement to fulfill their annual goal for the year.\

## Training Classifications

The Contractor shall provide on-the-job training aimed at developing full journeyman level workers in the construction craft/operator positions. Preference shall be given to providing training in the following skilled work classifications:

Equipment Operators	Office Engineers
Truck Drivers	Estimators
Carpenters	Iron / Reinforcing Steel Workers
Concrete Finishers	Mechanics
Pipe Layers	Welders

The Department has established common training classifications and their respective training requirements that may be used by the contractors. However, the classifications established are not all-inclusive. Where the training is oriented toward construction applications, training will be allowed in lower-level management positions such as office engineers and estimators. Contractors shall submit new classifications for specific job functions that their employees are performing. The Department will review and recommend for acceptance to FHWA the new classifications proposed by contractors, if applicable. New classifications shall meet the following requirements:

Proposed training classifications are reasonable and realistic based on the job skill classification needs, and

The number of training hours specified in the training classification is consistent with common practices and provides enough time for the trainee to obtain journeyman level status.

The Contractor may allow trainees to be trained by a subcontractor provided that the Contractor retains primary responsibility for meeting the training and this provision is made applicable to the subcontract. However, only the Contractor will receive credit towards the annual goal for the trainee.

Where feasible, 25 percent of apprentices or trainees in each occupation shall be in their first year of apprenticeship or training. The number of trainees shall be distributed among the work classifications on the basis of the contractor's needs and the availability of journeymen in the various classifications within a reasonable area of recruitment.

No employee shall be employed as a trainee in any classification in which they have successfully completed a training course leading to journeyman level status or in which they have been employed as a journeyman.

## Records and Reports

The Contractor shall maintain enrollment, monthly and completion reports documenting company compliance under these contract documents. These documents and any other information as requested shall be submitted to the OJT Program Manager.

Upon completion and graduation of the program, the Contractor shall provide each trainee with a certification Certificate showing the type and length of training satisfactorily completed.

**Trainee Interviews**

All trainees enrolled in the program will receive an initial and Trainee/Post graduate interview conducted by the OJT program staff.

**Trainee Wages**

Contractors shall compensate trainees on a graduating pay scale based upon a percentage of the prevailing minimum journeyman wages (Davis-Bacon Act). Minimum pay shall be as follows:

60 percent	of the journeyman wage for the first half of the training period
75 percent	of the journeyman wage for the third quarter of the training period
90 percent	of the journeyman wage for the last quarter of the training period

In no instance shall a trainee be paid less than the local minimum wage. The Contractor shall adhere to the minimum hourly wage rate that will satisfy both the NC Department of Labor (NCDOL) and the Department.

**Achieving or Failing to Meet Training Goals**

The Contractor will be credited for each trainee employed by him on the contract work who is currently enrolled or becomes enrolled in an approved program and who receives training for at least 50 percent of the specific program requirement. Trainees will be allowed to be transferred between projects if required by the Contractor's scheduled workload to meet training goals.

If a contractor fails to attain their training assignments for the calendar year, they may be taken off the NCDOT's Bidders List.

**Measurement and Payment**

No compensation will be made for providing required training in accordance with these contract documents.

**STANDARD SPECIAL PROVISION**  
**MINIMUM WAGES**  
**GENERAL DECISION NC170102 01/06/2017 NC102**

Z-102

Date: January 6, 2017

General Decision Number: NC170102 01/06/2017 NC102

Superseded General Decision Numbers: NC20160102

State: North Carolina

Construction Type: HIGHWAY

**COUNTIES:**

Caswell	Lee	Richmond
Davidson	Montgomery	Rowan
Iredell	Moore	Stanly

HIGHWAY CONSTRUCTION PROJECTS (excluding tunnels, building structures in rest area projects & railroad construction; bascule, suspension & spandrel arch bridges designed for commercial navigation, bridges involving marine construction; and other major bridges).

Note: Under Executive Order (EO) 13658, an hourly minimum wage of \$10.20 for calendar year 2017 that applies to all contracts subject to the Davis-Bacon Act for which the contract is awarded (and any solicitation was issued) on or after January 1, 2015. If this contract is covered by the EO, the contractor must pay all workers in any classification listed on this wage determination at least \$10.20 per hour (or the applicable wage rate listed on this wage determination, if it is higher) for all hours spent performing on the contract for calendar year 2017. The EO minimum wage rate will be adjusted annually. Additional information on contractor requirements and worker protections under the EO is available at [www.dol.gov/whd/govcontracts](http://www.dol.gov/whd/govcontracts).

Modification Number

0

Publication Date

01/06/2017

SUNC2014-004 11/17/2014

	Rates	Fringes
BLASTER	21.85	
CARPENTER	13.98	
CEMENT MASON/CONCRETE FINISHER	13.67	
ELECTRICIAN		
Electrician	19.19	2.39
Telecommunications Technician	14.96	1.07
IRONWORKER	14.53	
LABORER		
Asphalt Raker and Spreader	11.75	
Asphalt Screed/Jackman	14.03	
Carpenter Tender	10.21	
Cement Mason/Concrete Finisher Tender	12.26	
Common or General	10.45	.13
Guardrail/Fence Installer	13.43	
Pipelayer	13.36	.43
Traffic Signal/Lighting Installer	16.29	

	Rates	Fringes
<b>PAINTER</b>		
Bridge	19.62	
<b>POWER EQUIPMENT OPERATORS</b>		
Asphalt Broom Tractor	12.14	
Bulldozer Fine	16.92	
Bulldozer Rough	15.58	
Concrete Grinder/Groover	25.00	
Crane Boom Trucks	14.83	
Crane Other	21.05	
Crane Rough/All-Terrain	21.25	
Drill Operator Rock	15.43	1.61
Drill Operator Structure	19.24	
Excavator Fine	16.09	1.52
Excavator Rough	14.07	.74
Grader/Blade Fine	19.40	
Grader/Blade Rough	15.48	
Loader 2 Cubic Yards or Less	12.67	1.52
Loader Greater Than 2 Cubic Yards	14.48	
Material Transfer Vehicle (Shuttle Buggy)	17.39	
Mechanic	18.86	
Milling Machine	16.26	
Off-Road Hauler/Water Tanker	12.90	
Oiler/Greaser	16.36	
Pavement Marking Equipment	11.63	
Paver Asphalt	15.07	
Roller Asphalt Breakdown	12.91	
Roller Asphalt Finish	13.67	
Roller Other	13.48	
Scraper Finish	13.59	
Scraper Rough	11.53	
Slip Form Machine	19.99	
Tack Truck/Distributor Operator	15.60	
<b>TRUCK DRIVER</b>		
GVWR of 26,000 Lbs or Less	10.58	
GVWR of 26,000 Lbs or Greater	13.50	.15

Welders – Receive rate prescribed for craft performing operation to which welding is incidental.

Note: Executive Order (EO) 13706, Establishing Paid Sick Leave for Federal Contractors applies to all contracts subject to the Davis-Bacon Act for which the contract is awarded (and any solicitation was issued) on or after January 1, 2017. If this contract is covered by the EO, the contractor must provide employees with 1 hour of paid sick leave for every 30 hours they work, up to 56 hours of paid sick leave each year. Employees must be permitted to use paid sick leave for their own illness, injury or other health-related needs, including preventive care; to assist a family member (or person who is like family to the employee) who is ill, injured, or has other health-related needs, including preventive care; or for reasons resulting from, or to assist a family member (or person who is like family to the employee) who is a victim of, domestic violence, sexual assault, or stalking. Additional information on contractor requirements and worker protections under the EO is available at [www.dol.gov/whd/govcontracts](http://www.dol.gov/whd/govcontracts).

Unlisted classifications needed for work not included within the scope of the classifications listed may be added after award only as provided in the labor standards contract clauses (29 CFR 5.5(a)(1)(ii)).

The body of each wage determination lists the classification and wage rates that have been found to be prevailing for the cited type(s) of construction in the area covered by the wage determination. The classifications are listed in alphabetical order of "identifiers" that indicate whether the particular rate is a union rate (current union negotiated rate for local), a survey rate (weighted average rate) or a union average rate (weighted union average rate).

#### Union Rate Identifiers

A four letter classification abbreviation identifier enclosed in dotted lines beginning with characters other than "SU" or "UAVG" denotes that the union classification and rate were prevailing for that classification in the survey. Example: PLUM0198-005 07/01/2014. PLUM is an abbreviation identifier of the union which prevailed in the survey for this classification, which in this example would be Plumbers. 0198 indicates the local union number or district council number where applicable, i.e., Plumbers Local 0198. The next number, 005 in the example, is an internal number used in processing the wage determination. 07/01/2014 is the effective date of the most current negotiated rate, which in this example is July 1, 2014.

Union prevailing wage rates are updated to reflect all rate changes in the collective bargaining agreement (CBA) governing this classification and rate.

#### Survey Rate Identifiers

Classifications listed under the "SU" identifier indicate that no one rate prevailed for this classification in the survey and the published rate is derived by computing a weighted average rate based on all the rates reported in the survey for that classification. As this weighted average rate includes all rates reported in the survey, it may include both union and non-union rates. Example: SULA2012-007 5/13/2014. SU indicates the rates are survey rates based on a weighted average calculation of rates and are not majority rates. LA indicates the State of Louisiana. 2012 is the year of survey on which these classifications and rates are based. The next number, 007 in the example, is an internal number used in producing the wage determination. 5/13/2014 indicates the survey completion date for the classifications and rates under that identifier.

Survey wage rates are not updated and remain in effect until a new survey is conducted.

#### Union Average Rate Identifiers

Classification(s) listed under the UAVG identifier indicate that no single majority rate prevailed for those classifications; however, 100% of the data reported for the classifications was union data. EXAMPLE: UAVG-OH-0010 08/29/2014. UAVG indicates that the rate is a weighted union average rate. OH indicates the state. The next number, 0010 in the example, is an internal number used in producing the wage determination. 08/29/2014 indicates the survey completion date for the classifications and rates under that identifier.

A UAVG rate will be updated once a year, usually in January of each year, to reflect a weighted average of the current negotiated/CBA rate of the union locals from which the rate is based.

**WAGE DETERMINATION APPEALS PROCESS**

1.) Has there been an initial decision in the matter? This can be:

- \* an existing published wage determination
- \* a survey underlying a wage determination
- \* a Wage and Hour Division letter setting forth a position on a wage determination matter
- \* a conformance (additional classification and rate) ruling

On survey related matters, initial contact, including requests for summaries of surveys, should be with the Wage and Hour Regional Office for the area in which the survey was conducted because those Regional Offices have responsibility for the Davis-Bacon survey program. If the response from this initial contact is not satisfactory, then the process described in 2.) and 3.) should be followed.

With regard to any other matter not yet ripe for the formal process described here, initial contact should be with the Branch of Construction Wage Determinations. Write to:

Branch of Construction Wage Determinations  
Wage and Hour Division  
U. S. Department of Labor  
200 Constitution Avenue, N.W.  
Washington, D.C. 20210

2.) If the answer to the question in 1.) is yes, then an interested party (those affected by the action) can request review and reconsideration from the Wage and Hour Administrator (See 29 CFR Part 1.8 and 29 CFR Part 7). Write to:

Wage and Hour Administrator  
U.S. Department of Labor  
200 Constitution Avenue, N.W.  
Washington, D.C. 20210

The request should be accompanied by a full statement of the interested party's position and by any information (wage payment data, project description, area practice material, etc.) that the requestor considers relevant to the issue.

3.) If the decision of the Administrator is not favorable, an interested party may appeal directly to the Administrative Review Board (formerly the Wage Appeals Board). Write to:

Administrative Review Board  
U.S. Department of Labor  
200 Constitution Avenue, N.W.  
Washington, D.C. 20210

4.) All decisions by the Administrative Review Board are final. END OF GENERAL DECISION



# TC-1

## WORK ZONE TRAFFIC CONTROL FOR INTERSTATE/FREEWAY RESURFACING PROJECTS

### GENERAL REQUIREMENTS

This Provision is intended for Interstate/Freeway Resurfacing projects performed at night. In the event, the Day and time Restrictions allow for daytime work activities the Work zone Presence Lighting and Sequential Flashing Lights are to be omitted. However, the Digital Speed Limit Signs will be required as described below.

Maintain traffic in accordance with Divisions 10, 11 and 12 of the *2018 Standard Specifications* and the following provisions:

Install Work Zone Advance Warning Signs in accordance with the attached drawing prior to beginning any other work.

When personnel and/or equipment are working on the shoulder adjacent to a divided facility and within 10 feet of an open travel lane, close the nearest open travel lane using Standard Drawing No. 1101.02 of the *2018 Roadway Standard Drawings*.

When personnel and/or equipment are working within a lane of travel of a divided facility, close the lane using Standard Drawing No. 1101.02 of the *2018 Roadway Standard Drawings* or as directed by the Engineer. Conduct the work so that all personnel and/or equipment remain within the closed travel lane. Perform work only when weather and visibility conditions allow safe operations as directed by the Engineer.

#### **1. Time Restrictions for Lane Closure and Road Closure Activities**

All lane closure and road closure activities shall be performed in compliance with the Day and Time restrictions listed and defined in this Contract.

Any activities performed outside of these requirements will be subject to the Liquidated Damages unless approved by the Engineer prior to beginning the activity.

#### **2. Work Zone Speed Limits and Digital Speed Limit Signs (DSLS)**

All speed limits are to be ordinated by the State Traffic Engineer in order to have a lawfully enforceable speed limit; therefore, no speed limit messages/signs shall be installed prior to receiving a signed ordinance. NCDOT has sole authority of the speed limits displayed within the work zone.

The Regional Traffic Engineering Office and the Division Construction Engineer in coordination with the Work Zone Traffic Control Section will provide all Work Zone Speed Limit recommendations based on activities and conditions.

## TC-2

When lane closures are in effect and if ordained by the State Traffic Engineer, implement a Work Zone Variable Speed Limit Reduction as stated in the ordinance and in accordance with the attached Provision and drawing. Use Digital Speed Limit Signs (DSLS) to display the work zone speed limit as shown in the attached drawing. The Speed Limit shall be continuously displayed on the digital speed limit signs.

The Contractor will be responsible for coordinating with the Engineer when the Work Zone Speed Limits are to be changed and will have to seek approval by the Engineer before the Speed Limit is changed.

When the variable speed limit reductions are in effect, cover any existing speed limit signs located within the active work area that conflict with the variable speed limit reduction.

The speed limit shall be returned to the existing speed limit when the lane closure is removed and traffic is returned to the existing pattern.

### **3. Work Zone Presence Lighting and Sequential Flashing Warning Lights**

Provide the following for nighttime work activities in accordance with attached drawing and special provisions:

- A. Furnish and install Work Zone Presence Lighting to supplement the Contractor's portable construction and equipment lighting for the purpose of alerting motorist to the existence of an active work zone and to encourage compliance with the reduced work zone speed limit. (See attached Provision.)
- B. Furnish and install Sequential Flashing Warning Lights on drums used for merging tapers to assist motorist in determining which direction to merge and to decrease late lane merging. (See attached Provision.)

### **TEMPORARY TRAFFIC CONTROL (TTC)**

Refer to Standard Drawing No. 1101.02, 1101.11, 1110.01, 1110.02, 1115.01, 1130.01, 1135.01, 1165.01, and 1180.01 of the *2018 Roadway Standard Drawings* when closing a lane of travel in a stationary work zone for items such as milling, paving, diamond grinding concrete pavements, minor bridge and approach slab rehabilitation.

Drums are recommended for all lane closure operations occurring at night. However, if skinny drums are used at night, they shall be placed every 20' in the tangent sections of lane closure operations. Skinny drums shall not be used for upstream tapers.

When covering work zone signs, use an opaque material that prevents reading of the sign at night by a driver using high beam headlights. Use material, which does not damage the sign sheeting.

Refer to Standard Drawing No. 1101.02, Sheets 9 and 10 of the 2018 Roadway Standard Drawings for diamond grinding, milling and/or paving of ramps unless otherwise approved to be closed by the Engineer. If approved, see attached drawing for typical placement of devices and

## TC-3

signing for the detour route. All items shall be compensated for based on the unit bid price for the respective item.

Refer to Standard Drawing No. 1101.03, sheet 7 of the 2018 Roadway Standard Drawings for a closure of the interstate/freeway with traffic detoured via interchange ramps for items such as minor bridge and approach slab rehabilitation. Use Flaggers or Law Enforcement to direct traffic at ramp terminals as directed by the Engineer.

Refer to Standard Drawing No. 1101.02, sheet 12 or 13 of the *2018 Roadway Standard Drawings* for utilizing a Moving Operation for such items as pavement marking and marker placement. A minimum speed of 3 mph shall be maintained at all times with no stops that narrow or close a lane of travel. If the moving operation is progressing slower than 3 mph at any time, install a lane closure. All traffic control devices for this operation is considered incidental to the pay items for Pavement Marking and Markers.

### **TRAFFIC OPERATIONS**

#### **1. Project Requirements:**

Failure to comply with the following requirements will result in a suspension of all other operations:

- A. Before working on ANY MAP, the Contractor shall submit a written construction sequence for traffic control and construction lighting for ALL MAPS to the Engineer at the first pre-construction meeting and the sequence must be approved before closing a lane of traffic. The Contractor and Engineer will coordinate with the State Work Zone Engineer at 919-814-4937 for additional traffic control guidance, as necessary.
- B. The maximum "Active Work Area" is a distance of 5 miles. It is defined as the maximum allowable distance for Resurfacing Operations taking place in a single work period. Therefore, the maximum length of lane closure is 5 miles. However, approval by the Engineer is required before closing more than 2 miles of Interstate to ensure the Contractor has the equipment and labor force to actively pursue the work.
- C. Notify the Engineer 15 consecutive calendar days before resurfacing a bridge or its approaches. Patch and make repairs to bridge surface and its approaches before resurfacing occurs. Coordinate all operations on the bridge and its approaches with the Engineer
- D. Notify the Engineer 48 hours before resurfacing the areas of existing pavement that require patching. Patch these areas before resurfacing occurs. Allow full depth asphalt patching to cool to the point of supporting traffic without displacement or rutting before reopening closed lane. Coordinate the resurfacing operations of the patched areas with the Engineer.
- E. Notify the Engineer 48 hours before milling or resurfacing will interfere with the existing Signal Loops. Loops may need to be placed in milled surface before resurfacing occurs. Coordinate all signal loop operations with the Engineer.

## TC-4

- F. Obtain written approval of the Engineer before working in more than one location or setting up additional lane closures.
- G. The Contractor on this and any adjacent projects, or subcontractors working within this project shall coordinate lane closure location, type, and direction with the Engineer to best maintain lane continuity through the limits of this and adjacent projects.
- H. Operate equipment and conduct operations in the same direction as the flow of traffic. Maintain vehicular access in accordance with Article 1101-05 of the *2018 Standard Specifications*.
- I. Provide appropriate construction lighting in accordance with Section 1413 of the *2018 Standard Specifications*.
- J. Contractor shall diamond grind, mill and pave lanes in an order such that water shall not accumulate.

### **2. Paving Lift Requirements and Time Limitations:**

**Failure to comply with the following requirements will result in a suspension of all other operations until all lanes of traffic are brought to the same station and elevation:**

#### Paving Overlays and Lifts up to 3"

- A. For surface course paving lifts of 2.0" or less, the Contractor shall conduct his paving operations such that the following conditions are met.

Once paving begins in any lane, the Contractor will be permitted to pave as far as the work operations allow (up to 5 miles) for the initial paving period. In the next days' paving operation, not to exceed 72 hours, bring the adjacent lane to the same station and elevation. At the end of the work day, any uneven lane conditions shall be signed with an "UNEVEN PAVEMENT/NEXT XX MILES" on the portable changeable message signs and portable "UNEVEN PAVEMENT" signs (dual mounted) 1,000' in advance of the uneven pavement and every ½ miles thereafter along the uneven portion of roadway. Once mitigated, all portable "UNEVEN PAVEMENT" signs shall be removed.

For Open Graded Surface Mixes, "UNEVEN PAVEMENT" signs are not required. For 3" surface course mixes, place in two paving lifts of 1 ½" each unless directed otherwise by the Engineer. Conditions for uneven travel lanes same as described above.

#### Paving Lifts Greater than 3"

For all other paving lifts greater than 3", bring all newly resurfaced lanes to the same station and elevation by the end of each work day unless the Contractor utilizes the notched wedge paving methods as described below:

- A. Any paving lift greater than 3" shall be mitigated by having an approved wedge apparatus on

## TC-5

the paver that shapes the edge 1" vertically and the remaining at a maximum slope steepness of 2:1. The maximum paving lift allowed to use this method is 3".

- B. At the end of the work day, the Contractor shall place portable "UNEVEN PAVEMENT" signs in advance of the uneven pavement and spaced every ½ mile along the section of uneven pavement. Once mitigated, all portable "UNEVEN PAVEMENT" signs shall be removed.
- C. In the next day's paving operation and not to exceed 72 hours, the Contractor shall bring up the adjacent lane to the same station and elevation before any further paving takes place on the project.

### Milling Operations (Does Not Apply to Fine Milling)

Conduct milling operations so that any milled pavement is paved back by the end of each work day.

A milled/grooved surface shall not be re-opened to traffic except in cases where inclement weather or mechanical failure prevents the paving back of the lane by the end of the work day.

If milled areas are not paved back within the same work period due to inclement weather or mechanical failure, the Contractor is to furnish and install portable signs to warn drivers of the conditions. The signs include "Grooved Pavement" (W8-15) w/ Motorcycle Plaque mounted below, and "Uneven Lanes" (W8-11). These are to be dual indicated where lateral clearance can be obtained within the median areas. Install the "Grooved Pavement" (W8-15) w/ Motorcycle Plaque 1500' in advance of the milled area. Install the "Uneven Lanes" (W8-11) 500' in advance of the milled area. Alternate these signs every ½ mile. Once mitigated, all portable signs are to be removed.

Slope the pavement at the beginning and ending of the daily milling operation as directed by the Engineer. Sweep and remove all milled material from the roadway as soon as the daily milling operation is completed. Remove any existing pavement adjacent to the milled area that has been damaged and replace with patch material as directed by the Engineer.

### "Fine" Milling Operations (Depths less than 1.5")

For "fine" milling operations, paving is not required in the same work period. The paving of the "fine" milled area is to be conducted within the next work period and not to exceed 72 hours. No advance warning signs are needed for the conditions. However, pavement markings are required by the end of each work day.

### **3. Temporary Pavement Markings:**

Review and record the existing pavement markings and markers before obliteration. Re-establish the new pavement markings and markers using the record of existing markings in conjunction with the *2018 Roadway Standard Drawings* unless otherwise directed by the Engineer. Submit the record of the existing pavement markings seven calendar days before the obliteration of any pavement markings.

## TC-6

Obliterated pavement markings shall be replaced by the end of each workday's operation. Interim paint may be used to comply with time limitations if final pavement markings cannot be placed except for milled surfaces or diamond ground surfaces. Final markings shall be placed within 30 days in accordance with Section 1205-4 and Section 1205-5. For milled surfaces, temporary pavement markings shall be used in accordance with Section 1205-8(C). There will be no direct payment for interim paint. Temporary paint will be paid for at the contract unit price.

For concrete surfaces that have been diamond ground as a surface treatment, 4" temporary paint shall be used in accordance with Section 1205-8(C). Upon completion of all diamond grinding operations, 4" line removal shall be used to remove 100% of the 4" temporary paint on the final concrete surface by grinding method only. Use an acceptable method to grind ridges smooth only where pavement markings will be installed prior to placing final pavement marking material. This method shall also be used in the area of the black contrast for surface preparation. Payment for line removal will be made in accordance with Section 1205-10.

For project winterization, install temporary paint markings in accordance with Section 1205-8(C) of the 2018 Standard Specifications. Use 4" lane, edge, and center lines and 8" gore lines. Compensation for this work shall be made in accordance with Section 1205-10 except that no payment will be made if paving is completed more than 30 days before the written notification by the Department that winterization is required.

### 4. Work Zone Signing:

#### A. Description

Install advance/general warning work zone signs according to the attached drawings prior to beginning of work.

For paving overlays of 3" or greater that create a drop-off adjacent to the median shoulder, install "LOW/SOFT SHOULDER" (SP 13107) signs on the median shoulder. Place initially at the construction limits, and then space 1 mile thereafter. No signing required for the outside shoulder.

Install and maintain signing in accordance with the Divisions 11 and 12 of the *2018 Standard Specifications*.

#### B. Installation

All stationary Advance/General warning work zone signs require notification to existing Utility owners per Article 105-8 of the *2018 Standard Specifications* and Special Provision SP1 G115 within 3 to 12 full working days prior to installation.

Install all Advance/General warning work zone signs before beginning work on a particular map. If signs are installed more than seven (7) calendar days prior to the beginning of work on a particular map, cover the signs until the work begins. Install each work zone Advance/General warning sign separately and not on the same post or stand with any other

## TC-7

sign except where an advisory speed plate or directional arrow is used.

All sign locations to be verified by the Engineer prior to installation. Once the signs have been installed and accepted, any sign relocations requested by the Department will be compensated in accordance with Article 104-7. Any additional signs other than the ones required in this provision or attached drawings will be compensated in accordance with Article 104-7.

If there is a period of construction inactivity longer than 14 calendar days, remove or cover advance/general warning work zone signs. Uncover advance/general warning work zone signs no more than 7 calendar days before work resumes.

All other operations may be suspended upon failure to comply with the above requirements. Such suspended operations would not be resumed until the above requirements are fulfilled.

### C. Sign Removal

Once Maps on the Project are substantially completed, it is acceptable to remove the Stationary Work Zone Signs on those Maps in lieu of waiting until all of the Maps are completed on the Project. A Map is substantially complete when the resurfacing operations are completed and the shoulders are brought up to the same elevation as the proposed pavement and when all temporary pavement markings (paint) are installed along the mainline, ramps, and loops. The final pavement markings (Thermoplastic or Polyurea) and/or markers do not have to be installed for the Map to be considered substantially complete. Final Pavement Markings/Markers are installed with portable signing and changeable message signs according to Roadway Standard Drawing 1101.02, sheet 13. Any remaining punch list items requiring traffic control are to be completed with portable work zone signing with compensation covered in the Contract Unit price for price for the required Traffic Control items. Stationary Work Zone Sign removal is a condition of final project acceptance

### D. Lane Closure Work Zone Signs

Install any required lane closure signing needed during the life of the project in accordance with the Standard Drawing No. 1101.02, 1101.11 and 1110.02 of the *2018 Roadway Standard Drawings*.

## **MEASUREMENT AND PAYMENT**

Refer to the respective Sections of Division 11 and 12 of the *2018 Standard Specifications* or the attached Special Provisions for the satisfactory installation and removal of temporary traffic control devices and temporary pavement markings and markers.

Payment will be made under:

# TC-8

## Pay Item

Work Zone Signs (Stationary)  
Work Zone Signs (Portable)  
Work Zone Signs (Barricade Mounted)  
Flashing Arrow Board  
Portable Changeable Message Signs  
Portable Changeable Message Signs (Short Term)  
Drums  
Barricades (Type III)  
TMA  
Paint Pavement Marking Lines ( ”)  
Paint Pavement Marking Symbols  
Removal of Pavement Marking Lines ( ”)  
Law Enforcement

## Pay Unit

SF  
SF  
SF  
EA  
EA  
DAY  
EA  
LF  
EA  
LF  
EA  
LF  
HR

DocuSigned by:  
*Steve Kite*  
E27CE30E1DFC442...  
10/30/2017



---



# TC-9

## WORK ZONE TRAFFIC CONTROL Project Special Provisions

### WORK ZONE DIGITAL SPEED LIMIT SIGNS:

(10/08/2016)

#### **Description**

Furnish and install Work Zone Digital Speed Limit Signs on interstates and freeways with speed limits greater than 55 MPH and or facilities that have significant traffic volumes and impacts. These signs are regulatory speed limit signs with LED displays for the speed limit numbers. The purpose of Digital Speed Limit signs is to easily change work zone speed limits between activities that necessitate the need for a lower speed limit and the ones that do not.

#### **Materials**

Digital Speed Limit Signs shall be a minimum 36" wide x 48" high. The speed limit sign (R2-1) shall be black on white with high intensity white prismatic sheeting.

The Digital Speed Limit sign shall be mounted such that the bottom of the sign is 7' above roadway.

The LED panel shall be a minimum of 18" wide x 28" high. The display on the LED panel shall be amber or white.

The LED numbers shall have a minimum 5 wide by 7 high pixel array with a minimum height of 18".

The LED panel shall have auto brightness/dimming capability.

The black on orange "WORK ZONE" sign shall be mounted above the Speed Limit sign. It shall be 36" wide x 24" high with high intensity prismatic orange sheeting.

The black on white "\$250 FINE" sign shall be mounted below the Speed Limit sign. It shall be 36" wide x 24" high with high intensity prismatic white sheeting.

All digital speed limit systems shall have operational software and wireless communications that allows for remote operation and data monitoring. It shall be configured to allow access by the Engineer or his designee to change each sign independently or change the speed limit on all signs at once from a PC, tablet or cellular phone application.

Digital Speed Limit Signs may be trailer mounted or stationary mounted. The unit shall be Solar powered and have the ability to operate continuously. It shall be supplemented with a battery backup system which includes a 110/120 VAC powered on-board charging system.

The batteries, when fully charged; shall be capable of powering the display for 20 continuous days with no solar power. The unit shall be capable of being powered by standard 110/120 VAC power source.

# TC-10

Store the battery bank and charging system in a lockable, weather and vandal resistant box.

## **Optional Equipment/Capabilities**

Work Zone Digital Speed Limit systems may include speed data collection. If provided, this information is to be available in a spreadsheet format and accessed remotely from a secure cloud location.

The Work Zone Digital Speed Limit systems may have radar equipment to detect approaching speeds.

The Work Zone Digital Speed Limit systems may have flashing beacons. If used, the beacons are to be 12" diameter LED circular yellow. They may be mounted either above, beside or below the sign assemblies and are to be centered horizontally. If used, the beacons shall alternately flash at rates not less than 50 or more than 60 times per minute.

All Work Zone Digital Speed Limit equipment shall be on the NCDOT Work Zone Traffic Control Approved Products List.

## **Construction**

## **Methods**

The Speed Limit shall be continuously displayed on the signs. The speed limits are the sole authority of the NCDOT. All speed limits are to be ordinances by the State Traffic Engineer in order to have a lawfully enforceable speed limit.

The Regional Traffic Engineering Office and the Division Construction Engineer in coordination with the Work Zone Traffic Control Section will provide all Work Zone Speed Limit recommendations based on activities and conditions.

The Contractor will be responsible for coordinating with the Engineer when the Work Zone Speed Limits are to be changed and will have to seek approval by the Engineer or his designee before the Speed Limit is changed.

If the system has radar equipment and flashing beacons, the Digital Speed Limit systems shall have beacons activated when the "55 MPH" speed limit is being displayed. At all other speed limit displays (60 MPH, 65 MPH, 70 MPH), the beacons are not to be automatically activated until approaching speeds are detected to be 7 MPH or higher above the posted speed limit.

Whenever possible, each trailer mounted unit shall be placed on the paved shoulder and shall have the capability of being leveled.

## **Measurement and Payment**

# TC-11

The measurement for the Work Zone Digital Speed Limit Signs is made according to the number of Work Zone Digital Speed Limit signs required per the spacing requirements according to the attached drawing. Payment will be made for the maximum number of Work Zone Digital Speed Limit signs satisfactorily installed and properly functioning at any one time during the life of the project.

This includes all materials and labor to install, maintain and remove all the Work Zone Digital Speed Limit Units.

**Pay Item**

Work Zone Digital Speed Limit Signs

**Pay Unit**

Each

DocuSigned by:  
*Steve Kite*  
E27CE30E1DFC442...  
2/24/2017



# TC-12

## WORK ZONE TRAFFIC CONTROL Project Special Provisions

### **SEQUENTIAL FLASHING WARNING LIGHTS:**

(10/08/2016)

#### **Description**

Furnish and install Sequential Flashing Warning Lights on drums used for merging tapers during nightly work activities on interstates and freeways with speed limits greater than 55 MPH and or facilities that have significant traffic volumes.

The purpose of these lights is to assist the motorist in determining which direction to merge when approaching a lane closure. It's also designed to reduce the number of late merges resulting in devices being struck and having to be reset to maintain positive guidance at the merge point. The successive flashing of the lights shall occur from the upstream end of the merging taper to the downstream end of the merging taper in order to identify the desired vehicle path.

#### **Materials**

The Sequential Flashing Warning Lights shall meet all of the requirements for warning lights within the current edition of the Manual of Uniform Traffic Control Devices (MUTCD).

Each light unit shall be capable of operating fully and continuously for a minimum of 200 hours when equipped with a standard battery set.

Each light in the sequence shall be flashed at a rate of not less than 55 times per minute and not more than 75 times per minute. The flash rate and flash duration shall be consistent throughout the sequence.

Supply a Type 3 Certification (Independent Test Lab results) documenting all actual test results for the specified parameters contained in the Institute of Transportation Engineer's (ITE's) *Purchase Specification for Flashing and Steady Burn Warning Lights*. The laboratory shall also identify all manufacturer codes and part numbers for the incandescent lamp or LED clusters, lenses, battery, and circuitry, and the total width of the light with the battery in place. The complete assembly shall be certified as crashworthy when firmly affixed to the channelizing device.

All Sequential Flashing Warning Lights shall be on the NCDOT Work Zone Traffic Control Approved Products List.

#### **Construction Methods**

Sequential Flashing Warning Lights are to be used for night time lane closures.

These lights shall flash sequentially beginning with the first light and continuing until the final light.

# TC-13

The Sequential Flashing Warning Lights shall automatically flash in sequence when placed on the drums that form the merging taper.

The number of lights used in the drum taper shall equal the number of drums used in the taper.

Drums are the only channelizing device allowed to mount sequential flashing warning lights.

The Sequential Flashing Warning Lights shall be weather independent and visual obstructions shall not interfere with the operation of the lights.

The Sequential Flashing Warning Lights shall automatically sequence when placed in line in an open area with a distance between lights of 10 to 100 feet. A 10 foot stagger in the line of lights shall have no adverse effect on the operation of the lights.

If one light fails, the flashing sequence shall continue. If more than 1 light fails, all of the lights are to be automatically turned to the "off" mode. Non-sequential flashing is prohibited.

When lane closures are not in effect, the Sequential Flashing Warning Lights shall be deactivated.

## Measurement and Payment

Sequential Flashing Warning Lights will be measured and paid as the maximum number of sequential flashing warning lights satisfactorily installed and properly functioning at any one time during the life of the project.

This includes all materials and labor to install, maintain and remove all Sequential Flashing Warning Lights.

## Pay Item

Sequential Flashing Warning Lights

## Pay Unit

Each

DocuSigned by:  
*Steve Kite*  
E27CE30E1DFC442...

2/24/2017



# TC-14

## WORK ZONE TRAFFIC CONTROL Project Special Provisions

### WORK ZONE PRESENCE LIGHTING:

(10/08/2016)

#### Description

Furnish and install Work Zone Presence Lighting to supplement the Contractor's task (Portable Construction Lighting) and equipment lighting during nightly work activities on high speed (greater than 55 MPH) facilities and or facilities that have significant traffic volumes and impacts. The purpose of this additional lighting is to alert the motorist to the existence of an "active" work zone and to assist in compliance of the work zone speed limit by providing lighting in advance and throughout the length of the lane closure.

#### Materials

Anti-glare lighting systems are required. They are in addition to the Contractors' portable construction lighting. These devices shall be installed in accordance with the attached drawing and Manufacturer's recommendations.

All Work Zone Presence Lighting shall be supplied with a power source to provide the light output as described in the chart below.

All Work Zone Presence Lighting equipment shall be on the NCDOT Work Zone Traffic Control Approved Products List.

#### Construction Methods

Each light unit shall be capable of providing a minimum of 50,000 lumens illuminating a minimum area of approximately 20,000 square feet. The light shall be capable of being elevated to a height of 14 feet above the pavement. The lighting units shall be installed inside the full length of the lane closure as shown on the attached drawing and spaced according to the chart.

#### SPACING CHART

Light Output (Lumens)	Minimum Lighted Fixture Area (Square Feet)	Maximum Spacing (Feet)	Light Units (Per Mile)
50,000 to 65,000	5.5	750'	6
66,000 to 80,000	5.5	1,000'	5
81,000 to 100,000	36	1,250	4

# TC-15

Each light unit shall be installed along with the lane closure traffic control devices and moved as necessary to allow for efficient paving operations to take place as well as to not interfere with the Contractor's ability to light the work area.

Whenever possible, each light unit shall be placed on the 10' paved shoulder according to the above spacing based on the amount of light output for each unit. Each light unit support structure or mounting stand shall have the capability of being leveled.

## Measurement and Payment

The measurement for the Work Zone Presence Lighting is made according to the number of lighting units required per the spacing requirements and the attached drawing. Payment will be made for the maximum number of Work Zone Presence Lighting units satisfactorily installed and properly functioning at any one time during the life of the project. No measurement or separate payment will be made for power generators.

This includes all materials and labor to install, maintain and remove all the Work Zone Presence Lighting Units from the lane closure/s on a nightly basis.

## Pay Item

Work Zone Presence Lighting

## Pay Unit

Each

DocuSigned by:  
*Steve Kite*  
E27CE30E1DFC442...

2/24/2017



# EC-1

## **STABILIZATION REQUIREMENTS:**

(3-11-16)

S-3

Stabilization for this project shall comply with the time frame guidelines as specified by the NCG-010000 general construction permit effective August 3, 2011 issued by the North Carolina Department of Environment and Natural Resources Division of Water Quality. Temporary or permanent ground cover stabilization shall occur within 7 calendar days from the last land-disturbing activity, with the following exceptions in which temporary or permanent ground cover shall be provided in 14 calendar days from the last land-disturbing activity:

- Slopes between 2:1 and 3:1, with a slope length of 10 ft. or less
- Slopes 3:1 or flatter, with a slope of length of 50 ft. or less
- Slopes 4:1 or flatter

The stabilization timeframe for High Quality Water (HQW) Zones shall be 7 calendar days with no exceptions for slope grades or lengths. High Quality Water Zones (HQW) Zones are defined by North Carolina Administrative Code 15A NCAC 04A.0105 (25). Temporary and permanent ground cover stabilization shall be achieved in accordance with the provisions in this contract and as directed.

## **SEEDING AND MULCHING:**

(West)

The kinds of seed and fertilizer, and the rates of application of seed, fertilizer, and limestone, shall be as stated below. During periods of overlapping dates, the kind of seed to be used shall be determined. All rates are in pounds per acre.

### Shoulder and Median Areas

#### **August 1 - June 1**

20#	Kentucky Bluegrass
75#	Hard Fescue
25#	Rye Grain
500#	Fertilizer
4000#	Limestone

#### **May 1 - September 1**

20#	Kentucky Bluegrass
75#	Hard Fescue
10#	German or Browntop Millet
500#	Fertilizer
4000#	Limestone

### Areas Beyond the Mowing Pattern, Waste and Borrow Areas:

#### **August 1 - June 1**

100#	Tall Fescue
15#	Kentucky Bluegrass
30#	Hard Fescue
25#	Rye Grain
500#	Fertilizer
4000#	Limestone

#### **May 1 - September 1**

100#	Tall Fescue
15#	Kentucky Bluegrass
30#	Hard Fescue
10#	German or Browntop Millet
500#	Fertilizer
4000#	Limestone



## EC-2

### Approved Tall Fescue Cultivars

06 Dust	Escalade	Justice	Scorpion
2 <sup>nd</sup> Millennium	Essential	Kalahari	Serengeti
3 <sup>rd</sup> Millennium	Evergreen 2		Shelby
Apache III	Falcon IV	Kitty Hawk 2000	Sheridan
Avenger	Falcon NG	Legitimate	Signia
Barlexas	Falcon V	Lexington	Silver Hawk
Barlexas II	Faith	LSD	Sliverstar
Bar Fa	Fat Cat	Magellan	Shenandoah Elite
Barrera	Festnova	Matador	Sidewinder
Barrington	Fidelity	Millennium SRP	Skyline
Barrobusto	Finelawn Elite	Monet	Solara
Barvado	Finelawn Xpress	Mustang 4	Southern Choice II
Biltmore	Finesse II	Ninja 2	Speedway
Bingo	Firebird	Ol' Glory	Spyder LS
Bizem	Firecracker LS	Olympic Gold	Sunset Gold
Blackwatch	Firenza	Padre	Taccoa
Blade Runner II	Five Point	Patagonia	Tanzania
Bonsai	Focus	Pedigree	Trio
Braveheart	Forte	Picasso	Tahoe II
Bravo	Garrison	Piedmont	Talladega
Bullseye	Gazelle II	Plantation	Tarheel
Cannavaro	Gold Medallion	Proseeds 5301	Terrano
Catalyst	Grande 3	Prospect	Titan ltd
Cayenne	Greenbrooks	Pure Gold	Titanium LS
Cessane Rz	Greenkeeper	Quest	Tracer
Chipper	Gremlin	Raptor II	Traverse SRP
Cochise IV	Greystone	Rebel Exeda	Tulsa Time
Constitution	Guardian 21	Rebel Sentry	Turbo
Corgi	Guardian 41	Rebel IV	Turbo RZ
Corona	Hemi	Regiment II	Tuxedo RZ
Coyote	Honky Tonk	Regenerate	Ultimate
Darlington	Hot Rod	Rendition	Venture
Davinci	Hunter	Rhambler 2 SRP	Umbrella
Desire	Inferno	Rembrandt	Van Gogh
Dominion	Innovator	Reunion	Watchdog
Dynamic	Integrity	Riverside	Wolfpack II
Dynasty	Jaguar 3	RNP	Xtremegreen
Endeavor	Jamboree	Rocket	

## EC-3

### Approved Kentucky Bluegrass Cultivars:

4-Season	Blue Velvet	Gladstone	Quantum Leap
Alexa II	Blueberry	Granite	Rambo
America	Boomerang	Hampton	Rhapsody
Apollo	Brilliant	Harmonie	Rhythm
Arcadia	Cabernet	Impact	Rita
Aries	Champagne	Jefferson	Royce
Armada	Champlain	Juliet	Rubicon
Arrow	Chicago II	Jump Start	Rugby II
Arrowhead	Corsair	Keeneland	Shiraz
Aura	Courtyard	Langara	Showcase
Avid	Delight	Liberator	Skye
Award	Diva	Madison	Solar Eclipse
Awesome	Dynamo	Mercury	Sonoma
Bandera	Eagleton	Midnight	Sorbonne
Barduke	Emblem	Midnight II	Starburst
Barnique	Empire	Moon Shadow	Sudden Impact
Baroness	Envicta	Moonlight SLT	Total Eclipse
Barrister	Everest	Mystere	Touche
Barvette HGT	Everglade	Nu Destiny	Tsunami
Bedazzled	Excursion	NuChicago	Unique
Belissimo	Freedom II	NuGlade	Valor
Bewitched	Freedom III	Odyssey	Voyager II
Beyond	Front Page	Perfection	Washington
Blacksburg II	Futurity	Pinot	Zinfandel
Blackstone	Gaelic	Princeton 105	
Blue Note	Ginney II	Prosperity	

### Approved Hard Fescue Cultivars:

Aurora II	Eureka II	Oxford	Scaldis II
Aurora Gold	Firefly	Reliant II	Spartan II
Berkshire	Granite	Reliant IV	Stonehenge
Bighorn GT	Heron	Rescue 911	
Chariot	Nordic	Rhino	

On cut and fill slopes 2:1 or steeper add 20# Sericea Lespedeza January 1 - December 31.

Fertilizer shall be 10-20-20 analysis. A different analysis of fertilizer may be used provided the 1-2-2 ratio is maintained and the rate of application adjusted to provide the same amount of plant food as a 10-20-20 analysis and as directed.

# EC-4

## **WATTLE:**

(10-19-10) (Rev. 1-17-12)

1060,1630,1631

T1

### **Description**

Wattles are tubular products consisting of excelsior fibers encased in synthetic netting. Wattles are used on slopes or channels to intercept runoff and act as a velocity break. Wattles are to be placed at locations shown on the plans or as directed. Installation shall follow the detail provided in the plans and as directed. Work includes furnishing materials, installation of wattles, matting installation, and removing wattles.

### **Materials**

Wattle shall meet the following specifications:

100% Curled Wood(Excelsior) Fibers	
Minimum Diameter	12 in.
Minimum Density	2.5 lb/ft <sup>3</sup> +/- 10%
Net Material	Synthetic
Net Openings	1 in. x 1 in.
Net Configuration	Totally Encased
Minimum Weight	20 lb. +/- 10% per 10 ft. length

Stakes shall be used as anchors.

Provide hardwood stakes a minimum of 2 feet long with a 2 inch x 2 inch nominal square cross section. One end of the stake must be sharpened or beveled to facilitate driving down into the underlying soil.

Matting shall meet the requirements of Article 1060-8 of the *2018 Standard Specifications*, or shall meet specifications provided elsewhere in this contract.

Provide staples made of 0.125 inch diameter new steel wire formed into a *u* shape not less than 12 inches in length with a throat of 1 inch in width.

### **Construction Methods**

Wattles shall be secured to the soil by wire staples approximately every 1 linear foot and at the end of each section of wattle. A minimum of 4 stakes shall be installed on the downstream side of the wattle with a maximum spacing of 2 linear feet along the wattle, and according to the detail. Install a minimum of 2 stakes on the upstream side of the wattle according to the detail provided in the plans. Stakes shall be driven into the ground a minimum of 10 inches with no more than 2 inches projecting from the top of the wattle. Drive stakes at an angle according to the detail provided in the plans.

## EC-5

Only install wattle(s) to a height in ditch so flow will not wash around wattle and scour ditch slopes and according to the detail provided in the plans and as directed. Overlap adjoining sections of wattles a minimum of 6 inches.

Installation of matting shall be in accordance with the detail provided in the plans, and in accordance with Article 1631-3 of the *2018 Standard Specifications*, or in accordance with specifications provided elsewhere in this contract.

The Contractor shall maintain the wattles until the project is accepted or until the wattles are removed, and shall remove and dispose of silt accumulations at the wattles when so directed in accordance with the requirements of Section 1630 of the *2018 Standard Specifications*.

### **Measurement and Payment**

*Wattle* will be measured and paid for by the actual number of linear feet of wattles which are installed and accepted. Such price and payment will be full compensation for all work covered by this section, including, but not limited to, furnishing all materials, labor, equipment and incidentals necessary to install the *Wattle*.

Matting will be measured and paid for in accordance with Article 1631-4 of the *2018 Standard Specifications*, or in accordance with specifications provided elsewhere in this contract.

Payment will be made under:

<b>Pay Item</b>	<b>Pay Unit</b>
Wattle	Linear Foot

# BP-1

Project I-5793

Davidson County

## Project Special Provisions Structures

### Table of Contents

Scope of Work		BP-2
Falsework and Formwork	(4-5-12) -----	BP-2
Submittal of Working Drawings	(6-28-17) -----	BP-8
Grout for Structures	(11-30-17) -----	BP-15
Crane Safety	(8-15-05) -----	BP-15
Shotcrete Repairs	(12-5-12) -----	BP-16
Elastomeric Concrete	(9-27-12) -----	BP-20
Foam Joint Seals	(9-27-12) -----	BP-23
Painting Existing Weathering Steel Structure	(12-5-12) -----	BP-26
Cleaning and Painting Existing Bearings with HRCSA	(SPECIAL) -----	BP-40
Bridge Joint Demolition	(SPECIAL) -----	BP-54
Concrete Deck Repair for Epoxy Overlay	(SPECIAL) -----	BP-55
Epoxy Overlay System	(SPECIAL) -----	BP-56
Zone Painting of Existing Structure	(SPECIAL) -----	BP-61
Silicone Joint Sealant	(SPECIAL) -----	BP-74
Railroad General Special Provisions – CSX Transportation, Inc.	(SPECIAL) -----	BP-75

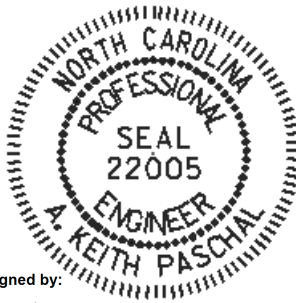

DocuSigned by:

*A. Keith Paschal*

11/29/2017

F8B6AD6DB2FC48F...

**SCOPE OF WORK**

This work shall consist of furnishing all labor, equipment, and materials to overlay the existing bridge decks with an epoxy overlay system, replace joints of the existing bridge, repair substructure, paint existing weathering steel, zone painting of existing structure, and clean and paint existing bearings with HRCSA as directed in the plans. Work includes: portable lighting, existing bridge deck surface preparation, removing bridge deck concrete using shotblasting and scarification methods, overlaying the prepared bridge deck with an epoxy overlay system, replacing joints, substructure repair, painting existing weathering steel, zone painting existing structure, cleaning and painting of existing bearings with HRCSA, disposal of waste material, grooving bridge deck, seeding and mulching all grassed areas disturbed; and all incidental items necessary to complete the project as specified and shown on the plans. No separate payment will be made for portable lighting as the cost of such is incidental to the work being performed.

Work will be performed on the existing bridges at the following locations in Davidson County:

- 1.) Bridge No. 474 – I-85 SBL over I-85 NBL
- 2.) Bridge No. 475 – I-85 NBL over Hamby's Creek
- 3.) Bridge No. 478 – I-85 NBL over SR 2025
- 4.) Bridge No. 479 – I-85 NBL over NC 109
- 5.) Bridge No. 480 – I-85 SBL over NC 109
- 6.) Bridge No. 485 – I-85 NBL over I-85 SBL
- 7.) Bridge No. 489 – SR 2085 over I-85
- 8.) Bridge No. 493 – I-85 NBL over Ferndale Drive
- 9.) Bridge No. 494 – I-85 SBL over Ferndale Drive
- 10.) Bridge No. 495 – I-85 NBL over CSX Railroad
- 11.) Bridge No. 496 – I-85 SBL over CSX Railroad

The contractor shall provide all necessary access; understructure platforms, scaffolding, ladders, etc.; provide all staging areas, material storage, waste disposal, provide environmental controls to limit loss of materials from sawing equipment, and chipping equipment; and all else necessary to complete the work.

The contractor shall be responsible for fulfilling all requirements of the NCDOT Standard Specifications for Roads and Structures dated January 2018, except as otherwise specified herein.

**FALSEWORK AND FORMWORK****(4-5-12)****1.0 DESCRIPTION**

Use this Special Provision as a guide to develop temporary works submittals required by the Standard Specifications or other provisions; no additional submittals are required herein. Such temporary works include, but are not limited to, falsework and formwork.

Falsework is any temporary construction used to support the permanent structure until it becomes self-supporting. Formwork is the temporary structure or mold used to retain plastic or fluid concrete in its designated shape until it hardens. Access scaffolding is a temporary

structure that functions as a work platform that supports construction personnel, materials, and tools, but is not intended to support the structure. Scaffolding systems that are used to temporarily support permanent structures (as opposed to functioning as work platforms) are considered to be falsework under the definitions given. Shoring is a component of falsework such as horizontal, vertical, or inclined support members. Where the term “temporary works” is used, it includes all of the temporary facilities used in bridge construction that do not become part of the permanent structure.

Design and construct safe and adequate temporary works that will support all loads imposed and provide the necessary rigidity to achieve the lines and grades shown on the plans in the final structure.

## **2.0 MATERIALS**

Select materials suitable for temporary works; however, select materials that also ensure the safety and quality required by the design assumptions. The Engineer has authority to reject material on the basis of its condition, inappropriate use, safety, or nonconformance with the plans. Clearly identify allowable loads or stresses for all materials or manufactured devices on the plans. Revise the plan and notify the Engineer if any change to materials or material strengths is required.

## **3.0 DESIGN REQUIREMENTS**

### **A. Working Drawings**

Provide working drawings for items as specified in the contract, or as required by the Engineer, with design calculations and supporting data in sufficient detail to permit a structural and safety review of the proposed design of the temporary work.

On the drawings, show all information necessary to allow the design of any component to be checked independently as determined by the Engineer.

When concrete placement is involved, include data such as the drawings of proposed sequence, rate of placement, direction of placement, and location of all construction joints. Submit the number of copies as called for by the contract.

When required, have the drawings and calculations prepared under the guidance of, and sealed by, a North Carolina Registered Professional Engineer who is knowledgeable in temporary works design.

If requested by the Engineer, submit with the working drawings manufacturer’s catalog data listing the weight of all construction equipment that will be supported on the temporary work. Show anticipated total settlements and/or deflections of falsework and forms on the working drawings. Include falsework footing settlements, joint take-up, and deflection of beams or girders.

As an option for the Contractor, overhang falsework hangers may be uniformly spaced, at a maximum of 36 inches, provided the following conditions are met:

# BP-4

Project I-5793

Davidson County

Member Type (PCG)	Member Depth, (inches)	Max. Overhang Width, (inches)	Max. Slab Edge Thickness, (inches)	Max. Screenshot Wheel Weight, (lbs.)	Bracket Min. Vertical Leg Extension, (inches)
II	36	39	14	2000	26
III	45	42	14	2000	35
IV	54	45	14	2000	44
MBT	63	51	12	2000	50
MBT	72	55	12	1700	48

Overhang width is measured from the centerline of the girder to the edge of the deck slab.

For Type II, III & IV prestressed concrete girders (PCG), 45-degree cast-in-place half hangers and rods must have a minimum safe working load of 6,000 lbs.

For MBT prestressed concrete girders, 45-degree angle holes for falsework hanger rods shall be cast through the girder top flange and located, measuring along the top of the member, 1'-2 1/2" from the edge of the top flange. Hanger hardware and rods must have a minimum safe working load of 6,000 lbs.

The overhang bracket provided for the diagonal leg shall have a minimum safe working load of 3,750 lbs. The vertical leg of the bracket shall extend to the point that the heel bears on the girder bottom flange, no closer than 4 inches from the bottom of the member. However, for 72-inch members, the heel of the bracket shall bear on the web, near the bottom flange transition.

Provide adequate overhang falsework and determine the appropriate adjustments for deck geometry, equipment, casting procedures and casting conditions.

If the optional overhang falsework spacing is used, indicate this on the falsework submittal and advise the girder producer of the proposed details. Failure to notify the Engineer of hanger type and hanger spacing on prestressed concrete girder casting drawings may delay the approval of those drawings.

Falsework hangers that support concentrated loads and are installed at the edge of thin top flange concrete girders (such as bulb tee girders) shall be spaced so as not to exceed 75% of the manufacturer's stated safe working load. Use of dual leg hangers (such as Meadow Burke HF-42 and HF-43) are not allowed on concrete girders with thin top flanges. Design the falsework and forms supporting deck slabs and overhangs on girder bridges so that there will be no differential settlement between the girders and the deck forms during placement of deck concrete.

When staged construction of the bridge deck is required, detail falsework and forms for screed and fluid concrete loads to be independent of any previous deck pour components when the mid-span girder deflection due to deck weight is greater than 3/4".



# BP-5

Note on the working drawings any anchorages, connectors, inserts, steel sleeves or other such devices used as part of the falsework or formwork that remains in the permanent structure. If the plan notes indicate that the structure contains the necessary corrosion protection required for a Corrosive Site, epoxy coat, galvanize or metalize these devices. Electroplating will not be allowed. Any coating required by the Engineer will be considered incidental to the various pay items requiring temporary works.

Design falsework and formwork requiring submittals in accordance with the 1995 AASHTO *Guide Design Specifications for Bridge Temporary Works* except as noted herein.

## 1. Wind Loads

Table 2.2 of Article 2.2.5.1 is modified to include wind velocities up to 110 mph. In addition, Table 2.2A is included to provide the maximum wind speeds by county in North Carolina.

**Table 2.2 - Wind Pressure Values**

Height Zone feet above ground	Pressure, lb/ft <sup>2</sup> for Indicated Wind Velocity, mph				
	70	80	90	100	110
0 to 30	15	20	25	30	35
30 to 50	20	25	30	35	40
50 to 100	25	30	35	40	45
over 100	30	35	40	45	50

## 2. Time of Removal

The following requirements replace those of Article 3.4.8.2.

Do not remove forms until the concrete has attained strengths required in Article 420-16 of the Standard Specifications and these Special Provisions.

Do not remove forms until the concrete has sufficient strength to prevent damage to the surface.

**BP-6**

Project I-5793

Davidson County

**Table 2.2A - Steady State Maximum Wind Speeds by Counties in North Carolina**

COUNTY	25 YR (mph)	COUNTY	25 YR (mph)	COUNTY	25 YR (mph)
Alamance	70	Franklin	70	Pamlico	100
Alexander	70	Gaston	70	Pasquotank	100
Alleghany	70	Gates	90	Pender	100
Anson	70	Graham	80	Perquimans	100
Ashe	70	Granville	70	Person	70
Avery	70	Greene	80	Pitt	90
Beaufort	100	Guilford	70	Polk	80
Bertie	90	Halifax	80	Randolph	70
Bladen	90	Harnett	70	Richmond	70
Brunswick	100	Haywood	80	Robeson	80
Buncombe	80	Henderson	80	Rockingham	70
Burke	70	Hertford	90	Rowan	70
Cabarrus	70	Hoke	70	Rutherford	70
Caldwell	70	Hyde	110	Sampson	90
Camden	100	Iredell	70	Scotland	70
Carteret	110	Jackson	80	Stanley	70
Caswell	70	Johnston	80	Stokes	70
Catawba	70	Jones	100	Surry	70
Cherokee	80	Lee	70	Swain	80
Chatham	70	Lenoir	90	Transylvania	80
Chowan	90	Lincoln	70	Tyrell	100
Clay	80	Macon	80	Union	70
Cleveland	70	Madison	80	Vance	70
Columbus	90	Martin	90	Wake	70
Craven	100	McDowell	70	Warren	70
Cumberland	80	Mecklenburg	70	Washington	100
Currituck	100	Mitchell	70	Watauga	70
Dare	110	Montgomery	70	Wayne	80
Davidson	70	Moore	70	Wilkes	70
Davie	70	Nash	80	Wilson	80
Duplin	90	New Hanover	100	Yadkin	70
Durham	70	Northampton	80	Yancey	70
Edgecombe	80	Onslow	100		
Forsyth	70	Orange	70		

**B. Review and Approval**

The Engineer is responsible for the review and approval of temporary works' drawings.

Submit the working drawings sufficiently in advance of proposed use to allow for their review, revision (if needed), and approval without delay to the work.

The time period for review of the working drawings does not begin until complete drawings and design calculations, when required, are received by the Engineer.

Do not start construction of any temporary work for which working drawings are required until the drawings have been approved. Such approval does not relieve the Contractor of the responsibility for the accuracy and adequacy of the working drawings.

**4.0 CONSTRUCTION REQUIREMENTS**

All requirements of Section 420 of the Standard Specifications apply.

Construct temporary works in conformance with the approved working drawings. Ensure that the quality of materials and workmanship employed is consistent with that assumed in the design of the temporary works. Do not weld falsework members to any portion of the permanent structure unless approved. Show any welding to the permanent structure on the approved construction drawings.

Provide tell-tales attached to the forms and extending to the ground, or other means, for accurate measurement of falsework settlement. Make sure that the anticipated compressive settlement and/or deflection of falsework does not exceed 1 inch. For cast-in-place concrete structures, make sure that the calculated deflection of falsework flexural members does not exceed 1/240 of their span regardless of whether or not the deflection is compensated by camber strips.

**A. Maintenance and Inspection**

Inspect and maintain the temporary work in an acceptable condition throughout the period of its use. Certify that the manufactured devices have been maintained in a condition to allow them to safely carry their rated loads. Clearly mark each piece so that its capacity can be readily determined at the job site.

Perform an in-depth inspection of an applicable portion(s) of the temporary works, in the presence of the Engineer, not more than 24 hours prior to the beginning of each concrete placement. Inspect other temporary works at least once a month to ensure that they are functioning properly. Have a North Carolina Registered Professional Engineer inspect the cofferdams, shoring, sheathing, support of excavation structures, and support systems for load tests prior to loading.

**B. Foundations**

Determine the safe bearing capacity of the foundation material on which the supports for temporary works rest. If required by the Engineer, conduct load tests to verify proposed bearing capacity values that are marginal or in other high-risk situations.

The use of the foundation support values shown on the contract plans of the permanent structure is permitted if the foundations are on the same level and on the same soil as those of the permanent structure.

Allow for adequate site drainage or soil protection to prevent soil saturation and washout of the soil supporting the temporary works supports.

If piles are used, the estimation of capacities and later confirmation during construction using standard procedures based on the driving characteristics of the pile is permitted. If preferred, use load tests to confirm the estimated capacities; or, if required by the Engineer conduct load tests to verify bearing capacity values that are marginal or in other high risk situations.

The Engineer reviews and approves the proposed pile and soil bearing capacities.

**5.0 REMOVAL**

Unless otherwise permitted, remove and keep all temporary works upon completion of the work. Do not disturb or otherwise damage the finished work.

Remove temporary works in conformance with the contract documents. Remove them in such a manner as to permit the structure to uniformly and gradually take the stresses due to its own weight.

**6.0 METHOD OF MEASUREMENT**

Unless otherwise specified, temporary works will not be directly measured.

**7.0 BASIS OF PAYMENT**

Payment at the contract unit prices for the various pay items requiring temporary works will be full compensation for the above falsework and formwork.

**SUBMITTAL OF WORKING DRAWINGS****(6-28-17)****1.0 GENERAL**

Submit working drawings in accordance with Article 105-2 of the *Standard Specifications* and this provision. For this provision, “submittals” refers to only those listed in this provision. The list of submittals contained herein does not represent a list of required submittals for the project. Submittals are only necessary for those items as required by the

# BP-9

Project I-5793

Davidson County

contract. Make submittals that are not specifically noted in this provision directly to the Engineer. Either the Structures Management Unit or the Geotechnical Engineering Unit or both units will jointly review submittals.

If a submittal contains variations from plan details or specifications or significantly affects project cost, field construction or operations, discuss the submittal with and submit all copies to the Engineer. State the reason for the proposed variation in the submittal. To minimize review time, make sure all submittals are complete when initially submitted. Provide a contact name and information with each submittal. Direct any questions regarding submittal requirements to the Engineer, Structures Management Unit contacts or the Geotechnical Engineering Unit contacts noted below.

In order to facilitate in-plant inspection by NCDOT and approval of working drawings, provide the name, address and telephone number of the facility where fabrication will actually be done if different than shown on the title block of the submitted working drawings. This includes, but is not limited to, precast concrete items, prestressed concrete items and fabricated steel or aluminum items.

## 2.0 ADDRESSES AND CONTACTS

For submittals to the Structures Management Unit, use the following addresses:

Via US mail:

Mr. B. C. Hanks, P. E.  
State Structures Engineer  
North Carolina Department  
of Transportation  
Structures Management Unit  
1581 Mail Service Center  
Raleigh, NC 27699-1581

Attention: Mr. J. L. Bolden, P. E.

Via other delivery service:

Mr. B. C. Hanks, P. E.  
State Structures Engineer  
North Carolina Department  
of Transportation  
Structures Management Unit  
1000 Birch Ridge Drive  
Raleigh, NC 27610

Attention: Mr. J. L. Bolden, P. E.

Submittals may also be made via email.

Send submittals to:

[jlbolden@ncdot.gov](mailto:jlbolden@ncdot.gov) (James Bolden)

Send an additional e-copy of the submittal to the following address:

[eomile@ncdot.gov](mailto:eomile@ncdot.gov) (Emmanuel Omile)

[mrorie@ncdot.gov](mailto:mrorie@ncdot.gov) (Madonna Rorie)

# BP-10

Project I-5793

Davidson County

For submittals to the Geotechnical Engineering Unit, use the following addresses:

For projects in Divisions 1-7, use the following Eastern Regional Office address:

Via US mail:

Mr. Chris Kreider, P. E.  
Eastern Regional Geotechnical  
Manager  
North Carolina Department  
of Transportation  
Geotechnical Engineering Unit  
Eastern Regional Office  
1570 Mail Service Center  
Raleigh, NC 27699-1570

Via other delivery service:

Mr. Chris Kreider, P. E.  
Eastern Regional Geotechnical  
Manager  
North Carolina Department  
of Transportation  
Geotechnical Engineering Unit  
Eastern Regional Office  
3301 Jones Sausage Road, Suite 100  
Garner, NC 27529

For projects in Divisions 8-14, use the following Western Regional Office address:

Via US mail:

Mr. Eric Williams, P. E.  
Western Regional Geotechnical  
Manager  
North Carolina Department  
of Transportation  
Geotechnical Engineering Unit  
Western Regional Office  
5253 Z Max Boulevard  
Harrisburg, NC 28075

Via other delivery service:

Mr. Eric Williams, P. E.  
Western Region Geotechnical  
Manager  
North Carolina Department  
of Transportation  
Geotechnical Engineering Unit  
Western Regional Office  
5253 Z Max Boulevard  
Harrisburg, NC 28075

The status of the review of structure-related submittals sent to the Structures Management Unit can be viewed from the Unit's web site, via the "Drawing Submittal Status" link.

Direct any questions concerning submittal review status, review comments or drawing markups to the following contacts:

Primary Structures Contact:	James Bolden	(919) 707 - 6408 (919) 250 - 4082 facsimile <a href="mailto:jlbolden@ncdot.gov">jlbolden@ncdot.gov</a>
Secondary Structures Contacts:	Emmanuel Omile Madonna Rorie	(919) 707 - 6451 (919) 707 - 6508

# BP-11

Project I-5793

Davidson County

Eastern Regional Geotechnical Contact (Divisions 1-7):

Chris Kreider (919) 662 – 4710  
(919) 662 – 3095 facsimile  
[ckreider@ncdot.gov](mailto:ckreider@ncdot.gov)

Western Regional Geotechnical Contact (Divisions 8-14):

Eric Williams (704) 455 – 8902  
(704) 455 – 8912 facsimile  
[ewilliams3@ncdot.gov](mailto:ewilliams3@ncdot.gov)

### 3.0 SUBMITTAL COPIES

Furnish one complete copy of each submittal, including all attachments, to the Engineer. At the same time, submit the number of hard copies shown below of the same complete submittal directly to the Structures Management Unit and/or the Geotechnical Engineering Unit.

The first table below covers “Structure Submittals”. The Engineer will receive review comments and drawing markups for these submittals from the Structures Management Unit. The second table in this section covers “Geotechnical Submittals”. The Engineer will receive review comments and drawing markups for these submittals from the Geotechnical Engineering Unit.

Unless otherwise required, submit one set of supporting calculations to either the Structures Management Unit or the Geotechnical Engineering Unit unless both units require submittal copies in which case submit a set of supporting calculations to each unit. Provide additional copies of any submittal as directed.

#### STRUCTURE SUBMITTALS

<b>Submittal</b>	<b>Copies Required by Structures Management Unit</b>	<b>Copies Required by Geotechnical Engineering Unit</b>	<b>Contract Reference Requiring Submittal <sup>1</sup></b>
Arch Culvert Falsework	5	0	Plan Note, SN Sheet & “Falsework and Formwork”
Box Culvert Falsework <sup>7</sup>	5	0	Plan Note, SN Sheet & “Falsework and Formwork”
Cofferdams	6	2	Article 410-4
Foam Joint Seals <sup>6</sup>	9	0	“Foam Joint Seals”

# BP-12

Project I-5793

Davidson County

Expansion Joint Seals (hold down plate type with base angle)	9	0	“Expansion Joint Seals”
Expansion Joint Seals (modular)	2, then 9	0	“Modular Expansion Joint Seals”
Expansion Joint Seals (strip seals)	9	0	“Strip Seals”
Falsework & Forms <sup>2</sup> (substructure)	8	0	Article 420-3 & “Falsework and Formwork”
Falsework & Forms (superstructure)	8	0	Article 420-3 & “Falsework and Formwork”
Girder Erection over Railroad	5	0	Railroad Provisions
Maintenance and Protection of Traffic Beneath Proposed Structure	8	0	“Maintenance and Protection of Traffic Beneath Proposed Structure at Station ____”
Metal Bridge Railing	8	0	Plan Note
Metal Stay-in-Place Forms	8	0	Article 420-3
Metalwork for Elastomeric Bearings <sup>4,5</sup>	7	0	Article 1072-8
Miscellaneous Metalwork <sup>4,5</sup>	7	0	Article 1072-8
Disc Bearings <sup>4</sup>	8	0	“Disc Bearings”
Overhead and Digital Message Signs (DMS) (metalwork and foundations)	13	0	Applicable Provisions
Placement of Equipment on Structures (cranes, etc.)	7	0	Article 420-20
Precast Concrete Box Culverts	2, then 1 reproducible	0	“Optional Precast Reinforced Concrete Box Culvert at Station ____”
Prestressed Concrete Cored Slab (detensioning sequences) <sup>3</sup>	6	0	Article 1078-11
Prestressed Concrete Deck Panels	6 and 1 reproducible	0	Article 420-3



# BP-13

Project I-5793

Davidson County

Prestressed Concrete Girder (strand elongation and detensioning sequences)	6	0	Articles 1078-8 and 1078- 11
Removal of Existing Structure over Railroad	5	0	Railroad Provisions
Revised Bridge Deck Plans (adaptation to prestressed deck panels)	2, then 1 reproducible	0	Article 420-3
Revised Bridge Deck Plans (adaptation to modular expansion joint seals)	2, then 1 reproducible	0	“Modular Expansion Joint Seals”
Sound Barrier Wall (precast items)	10	0	Article 1077-2 & “Sound Barrier Wall”
Sound Barrier Wall Steel Fabrication Plans <sup>5</sup>	7	0	Article 1072-8 & “Sound Barrier Wall”
Structural Steel <sup>4</sup>	2, then 7	0	Article 1072-8
Temporary Detour Structures	10	2	Article 400-3 & “Construction, Maintenance and Removal of Temporary Structure at Station _____”
TFE Expansion Bearings <sup>4</sup>	8	0	Article 1072-8

## FOOTNOTES

1. References are provided to help locate the part of the contract where the submittals are required. References in quotes refer to the provision by that name. Articles refer to the *Standard Specifications*.
2. Submittals for these items are necessary only when required by a note on plans.
3. Submittals for these items may not be required. A list of pre-approved sequences is available from the producer or the Materials & Tests Unit.
4. The fabricator may submit these items directly to the Structures Management Unit.
5. The two sets of preliminary submittals required by Article 1072-8 of the *Standard Specifications* are not required for these items.
6. Submittals for Fabrication Drawings are not required. Submittals for Catalogue Cuts of Proposed Material are required. See Section 5.A of the referenced provision.
7. Submittals are necessary only when the top slab thickness is 18” or greater.

# BP-14

Project I-5793

Davidson County

## GEOTECHNICAL SUBMITTALS

<b>Submittal</b>	<b>Copies Required by Geotechnical Engineering Unit</b>	<b>Copies Required by Structures Management Unit</b>	<b>Contract Reference Requiring Submittal <sup>1</sup></b>
Drilled Pier Construction Plans <sup>2</sup>	1	0	Subarticle 411-3(A)
Crosshole Sonic Logging (CSL) Reports <sup>2</sup>	1	0	Subarticle 411-5(A)(2)
Pile Driving Equipment Data Forms <sup>2,3</sup>	1	0	Subarticle 450-3(D)(2)
Pile Driving Analyzer (PDA) Reports <sup>2</sup>	1	0	Subarticle 450-3(F)(3)
Retaining Walls <sup>4</sup>	8 drawings, 2 calculations	2 drawings	Applicable Provisions
Temporary Shoring <sup>4</sup>	5 drawings, 2 calculations	2 drawings	“Temporary Shoring” & “Temporary Soil Nail Walls”

### FOOTNOTES

1. References are provided to help locate the part of the contract where the submittals are required. References in quotes refer to the provision by that name. Subarticles refer to the *Standard Specifications*.
2. Submit one hard copy of submittal to the Engineer. Submit a second copy of submittal electronically (PDF via email) or by facsimile, US mail or other delivery service to the appropriate Geotechnical Engineering Unit regional office. Electronic submission is preferred.
3. The Pile Driving Equipment Data Form is available from:  
[https://connect.ncdot.gov/resources/Geological/Pages/Geotech\\_Forms\\_Details.aspx](https://connect.ncdot.gov/resources/Geological/Pages/Geotech_Forms_Details.aspx)  
See second page of form for submittal instructions.
4. Electronic copy of submittal is required. See referenced provision.

**GROUT FOR STRUCTURES****(11-30-17)****1.0 DESCRIPTION**

This special provision addresses grout for use in pile blockouts, grout pockets, shear keys, dowel holes and recesses for structures. This provision does not apply to grout placed in post-tensioning ducts for bridge beams, girders, decks, end bent caps, or bent caps. Mix and place grout in accordance with the manufacturer's recommendations, the applicable sections of the Standard Specifications and this provision.

**2.0 MATERIAL REQUIREMENTS**

Unless otherwise noted on the plans, use a Type 3 Grout in accordance with Section 1003 of the Standard Specifications.

Initial setting time shall not be less than 10 minutes when tested in accordance with ASTM C266.

Construction loading and traffic loading shall not be allowed until the 3 day compressive strength is achieved.

**3.0 SAMPLING AND PLACEMENT**

Place and maintain components in final position until grout placement is complete and accepted. Concrete surfaces to receive grout shall be free of defective concrete, laitance, oil, grease and other foreign matter. Saturate concrete surfaces with clean water and remove excess water prior to placing grout.

**4.0 BASIS OF PAYMENT**

No separate payment will be made for "Grout for Structures". The cost of the material, equipment, labor, placement, and any incidentals necessary to complete the work shall be considered incidental to the structure item requiring grout.

**CRANE SAFETY****(8-15-05)**

Comply with the manufacturer specifications and limitations applicable to the operation of any and all cranes and derricks. Prime contractors, sub-contractors, and fully operated rental companies shall comply with the current Occupational Safety and Health Administration regulations (OSHA).

Submit all items listed below to the Engineer prior to beginning crane operations involving critical lifts. A critical lift is defined as any lift that exceeds 75 percent of the manufacturer's crane chart capacity for the radius at which the load will be lifted or requires the use of more than one crane. Changes in personnel or equipment must be reported to the Engineer and all applicable items listed below must be updated and submitted prior to continuing with crane operations.

# BP-16

Project I-5793

Davidson County

## CRANE SAFETY SUBMITTAL LIST

- A. **Competent Person:** Provide the name and qualifications of the “Competent Person” responsible for crane safety and lifting operations. The named competent person will have the responsibility and authority to stop any work activity due to safety concerns.
- B. **Riggers:** Provide the qualifications and experience of the persons responsible for rigging operations. Qualifications and experience should include, but not be limited to, weight calculations, center of gravity determinations, selection and inspection of sling and rigging equipment, and safe rigging practices.
- C. **Crane Inspections:** Inspection records for all cranes shall be current and readily accessible for review upon request.
- D. **Certifications:** By July 1, 2006, crane operators performing critical lifts shall be certified by NC CCO (National Commission for the Certification of Crane Operators), or satisfactorily complete the Carolinas AGC’s Professional Crane Operator's Proficiency Program. Other approved nationally accredited programs will be considered upon request. All crane operators shall also have a current CDL medical card. Submit a list of anticipated critical lifts and corresponding crane operator(s). Include current certification for the type of crane operated (small hydraulic, large hydraulic, small lattice, large lattice) and medical evaluations for each operator.

## SHOTCRETE REPAIRS

(12-5-12)

### GENERAL

The work covered by this Special Provision consists of removing deteriorated concrete from the structure in accordance with the limits, depth and details shown on the plans, described herein and as established by the Engineer. This work also includes removing and disposing all loose debris, cleaning and repairing reinforcing steel and applying shotcrete.

The location and extent of repairs shown on the plans are general in nature. The Engineer shall determine the extent of removal in the field based on an evaluation of the condition of the exposed surfaces.

Any portion of the structure that is damaged from construction operations shall be repaired to the Engineer’s satisfaction, at no extra cost to the Department.

### MATERIAL REQUIREMENTS

Use prepackaged shotcrete conforming to the requirements of ASTM C1480, the applicable sections of the Standard Specifications and the following:

Test Description	Test Method	Age (Days)	Specified Requirements
Silica Fume (%)	ASTM C1240	-	10 (Max.)

# BP-17

Project I-5793

Davidson County

Water/Cementitious Materials Ratio	-	-	0.40 (Max.)
Air Content - As Shot (%)	ASTM C231	-	4 ± 1
Slump - As Shot (Range in inches)	ASTM C143	-	2 - 3
Minimum Compressive Strength (psi)	ASTM C39	7 28	3,000 5,000
Minimum Bond Pull-off Strength (psi)	ASTM C1583	28	145
Rapid Chloride Permeability Tests (range in coulombs)	ASTM C1202	-	100 - 1000

Admixtures are not allowed unless approved by the Engineer. Store shotcrete in an environment where temperatures remain above 40°F and less than 95°F

All equipment must operate in accordance with the manufacturer's specifications and material must be placed within the recommended time.

## QUALITY CONTROL

### A. Qualification of Shotcrete Contractor

The shotcrete Contractor shall provide proof of experience by submitting a description of jobs similar in size and character that have been completed within the last 5 years. The name, address and telephone number of references for the submitted projects shall also be furnished. Failure to provide appropriate documentation will result in the rejection of the proposed shotcrete contractor.

### B. Qualification of Nozzleman

The shotcrete Contractor's nozzleman shall be certified by the American Concrete Institute (ACI). Submit proof of certification to the Engineer prior to beginning repair work. The nozzleman shall maintain certification at all times while work is being performed for the Department. Failure to provide and maintain certification will result in the rejection of the proposed nozzleman.

## TEMPORARY WORK PLATFORM

Prior to beginning any repair work, provide details for a sufficiently sized temporary work platform at each repair location. Design steel members to meet the requirements of the American Institute of Steel Construction Manual. Design timber members in accordance with the "National Design Specification for Stress-Grade Lumber and Its Fastenings" of the National Forest Products Association. Submit the platform design and plans for review and

# BP-18

Project I-5793

Davidson County

approval. The design and plans shall be sealed and signed by a North Carolina registered Professional Engineer. Do not install the platform until the design and plans are approved. Drilling holes in the superstructure for the purpose of attaching the platform is prohibited. Upon completion of work, remove all anchorages in the substructure and repair the substructure at no additional cost to the Department.

## **SURFACE PREPARATION**

Prior to starting the repair operation, delineate all surfaces and areas assumed to be deteriorated by visually examining and sounding the concrete surface with a hammer or other approved method. The Engineer is the sole judge in determining the limits of deterioration.

Prior to removal, introduce a shallow saw cut approximately 1/2" in depth around the repair area at right angles to the concrete surface. Remove all deteriorated concrete 1 inch below the reinforcing steel with a 17 lb (maximum) pneumatic hammer with points that do not exceed the width of the shank or with hand picks or chisels as directed by the Engineer. Do not cut or remove the existing reinforcing steel. Unless specifically directed by the Engineer, do not remove concrete deeper than 1 inch below the reinforcing steel.

Abrasive blast all exposed concrete surfaces and existing reinforcing steel in repair areas to remove all debris, loose concrete, loose mortar, rust, scale, etc. Use a wire brush to clean all exposed reinforcing steel. After sandblasting examine the reinforcing steel to ensure at least 90% of the original diameter remains. If there is more than 10% reduction in the rebar diameter, splice in and securely tie supplemental reinforcing bars as directed by the Engineer.

Provide welded stainless wire fabric at each repair area larger than one square foot if the depth of the repair exceeds 2 inches from the "As Built" outside face. Provide a minimum 4" x 4" - 12 gage stainless welded wire fabric unless otherwise shown on the plans. Rigidly secure the welded wire fabric to existing steel or to 3/16" diameter stainless hook fasteners adequately spaced to prevent sagging. Encase the welded wire fabric in shotcrete a minimum depth of 1 1/2 inches.

The contractor has the option to use synthetic fiber reinforcement as an alternate to welded wire fabric if attaching welded wire fabric is impractical or if approved by the Engineer. Welded wire fabric and synthetic fiber reinforcement shall not be used in the same repair area.

Thoroughly clean the repair area of all dirt, grease, oil or foreign matter, and remove all loose or weakened material before applying shotcrete. Saturate the repair area with clean water the day before applying shotcrete. Bring the wetted surface to a saturated surface dry (SSD) condition prior to applying shotcrete and maintain this condition until the application begins. Use a blowpipe to facilitate removal of free surface water. Only oil-free compressed air is to be used in the blowpipe.

The time between removal of deteriorated concrete and applying shotcrete shall not exceed 5 days. If the time allowance exceeds 5 days, prepare the surface at the direction of the Engineer before applying shotcrete.

## **APPLICATION AND SURFACE FINISH**

Apply shotcrete only when the surface temperature of the repair area is greater than 40°F and less than 95°F. Do not apply shotcrete to frosted surfaces. Maintain shotcrete at a minimum temperature of 40°F for 3 days after placement.

Apply shotcrete in layers. The properties of the applied shotcrete determine the proper thickness of each layer or lift.

The nozzleman should hold the nozzle 3 to 4 feet from the surface being covered in a position that ensures the shotcrete strikes at right angles to the surface being covered without excessive impact. The nozzleman shall maintain the water amount at a practicable minimum, so the mix properly adheres to the repair area. Water content should not become high enough to cause the mix to sag or fall from vertical or inclined surfaces, or to separate in horizontal layers.

Use shooting wires or guide strips that do not entrap rebound sand. Use guide wires to provide a positive means of checking the total thickness of the shotcrete applied. Remove the guide wires prior to the final finish coat.

To avoid leaving sand pockets in the shotcrete, blow or rake off sand that rebounds and does not fall clear of the work, or which collects in pockets in the work. Do not reuse rebound material in the work.

If a work stoppage longer than 2 hours takes place on any shotcrete layer prior to the time it has been built up to required thickness, saturate the area with clean water and use a blowpipe as outlined previously, prior to continuing with the remaining shotcrete course. Do not apply shotcrete to a dry surface.

Finish all repaired areas, including chamfered edges, as close as practicable to their original "As Built" dimensions and configuration. Provide a minimum 2" of cover for reinforcing steel exposed during repair. Slightly build up and trim shotcrete to the final surface by cutting with the leading edge of a sharp trowel. Use a rubber float to correct any imperfections. Limit work on the finished surface to correcting imperfections caused by trowel cutting.

Immediately after bringing shotcrete surfaces to final thickness, thoroughly check for sags, bridging, and other deficiencies. Repair any imperfections at the direction of the Engineer.

Prevent finished shotcrete from drying out by maintaining 95% relative humidity at the repair and surrounding areas by fogging, moist curing or other approved means for seven days.

## **MATERIAL TESTING & ACCEPTANCE**

Each day shotcreting takes place, the nozzleman shall shoot one 18" x 18" x 3" test panel in the same position as the repair work that is being done to demonstrate the shotcrete is being applied properly. Store, handle and cure the test panel in the same manner as the repaired substructure.

# BP-20

Project I-5793

Davidson County

Approximately 72 hours after completing the final shotcrete placement, thoroughly test the surface with a hammer. At this time, the repair area should have sufficient strength for all sound sections to ring sharply. Remove and replace any unsound portions prior to the final inspection of the work. No additional compensation will be provided for removal and replacement of unsound shotcrete.

After 7 days, core three 3" diameter samples from each test panel and from the repaired structure as directed by the Engineer. Any cores taken from the structure shall penetrate into the existing structure concrete at least 2 inches. Cores shall be inspected for delamination, sand pockets, tested for bond strength and compressive strength. If a core taken from a repaired structure unit indicates unsatisfactory application or performance of the shotcrete, take additional cores from the applicable structure unit(s) for additional evaluation and testing as directed by the Engineer. Any repair work failing to meet the requirements of this provision will be rejected and the Contractor shall implement a remediation plan to correct the deficiency at no additional cost to the Department. No extra payment will be provided for drilling extra cores. Patch all core holes in repaired structure units to the satisfaction of the Engineer. All material testing, core testing and sampling will be done by the Materials and Tests Unit of North Carolina Department of Transportation.

## MEASUREMENT AND PAYMENT

Shotcrete Repairs will be measured and paid for at the contract unit price bid per cubic foot and will be full compensation for removal, containment and disposal off-site of unsound concrete including the cost of materials, labor, tools, equipment and incidentals necessary to complete the repair work. Depth will be measured from the original outside concrete face. The Contractor and Engineer will measure quantities after removal of unsound concrete and before application of repair material. Payment will also include the cost of sandblasting, surface cleaning and preparation, cleaning of reinforcing steel, placement of new steel, cost of temporary work platform, testing for soundness, curing of shotcrete and taking core samples from the test panels and substructure units.

Payment will be made under:

<b>Pay Item</b>	<b>Pay Unit</b>
Shotcrete Repairs	Cubic Feet

## ELASTOMERIC CONCRETE

(SPECIAL)

### 1.0 DESCRIPTION

Elastomeric concrete is a mixture of a two-part polymer consisting of polyurethane and/or epoxy and kiln-dried aggregate. Provide an elastomeric concrete and binder system that is preapproved. Use the concrete in the blocked out areas on both sides of the bridge deck joints as indicated on the plans.

### 2.0 MATERIALS



# BP-21

Project I-5793

Davidson County

Provide materials that comply with the following minimum requirements at 14 days (or at the end of the specified curing time).

<b>ELASTOMERIC CONCRETE PROPERTIES</b>	<b>TEST METHOD</b>	<b>MINIMUM REQUIREMENT</b>
Compressive Strength, psi	ASTM D695	2000
5% Deflection Resilience	ASTM D695	95
Splitting Tensile Strength, psi	ASTM D3967	625
Bond Strength to Concrete, psi	ASTM D882 (D882M)	450
Durometer Hardness	ASTM D2240	50

<b>BINDER PROPERTIES (without aggregate)</b>	<b>TEST METHOD</b>	<b>MINIMUM REQUIREMENT</b>
Tensile Strength, psi	ASTM D638	1000
Ultimate Elongation	ASTM D638	150%
Tear Resistance, lb/in	ASTM D624	200

In addition to the requirements above, the elastomeric concrete must be resistant to water, chemical, UV and ozone exposure and withstand temperature extremes. Elastomeric concrete systems requiring preheated aggregates are not allowed.

### 3.0 PREQUALIFICATION

Manufacturers of elastomeric concrete materials shall submit samples (including aggregate, primer, and binder materials) and a Type 3 certification in accordance with Article 106-3 of the Standard Specifications for prequalification to:

North Carolina Department of Transportation  
Materials and Tests Unit  
1801 Blue Ridge Road  
Raleigh, NC 27607

Prequalification will be determined for the system. Individual components will not be evaluated, nor will individual components of previously evaluated systems be deemed prequalified for use.

The submitted binder (a minimum volume of 1 gallon) and corresponding aggregate samples will be evaluated for compliance with the Materials requirements specified above. Systems satisfying all of the Materials requirements will be prequalified for a one year period. Before

the end of this period, new product samples shall be resubmitted for prequalification evaluation.

If, at any time, any formulation or component modifications are made to a prequalified system that system will no longer be approved for use.

#### **4.0 INSTALLATION**

The elastomeric concrete shall not be placed until the reinforced concrete deck slab has cured for seven full days and reached a minimum strength of 3000 psi.

Provide a manufacturer's representative at the bridge site during the installation of the elastomeric concrete to ensure that all steps being performed comply with all manufacturer installation requirements including, but not limited to weather conditions (ambient temperature, relative humidity, precipitation, wind, etc.), concrete deck surface preparation, binder and aggregate mixing, primer application, elastomeric concrete placement, curing conditions and minimum curing time before joint exposure to traffic. Do not place elastomeric concrete if the ambient air or surface temperature is below 45°F.

Prepare the concrete surface within 48 hours prior to placing the elastomeric concrete. Before placing the elastomeric concrete, all concrete surfaces shall be thoroughly cleaned and dry. Sandblast the concrete surface in the blockout and clear the surface of all loose debris. Do not place the elastomeric concrete until the surface preparation is completed and approved.

Prepare and apply a primer, as per manufacturer's recommendations, to all concrete faces to be in contact with elastomeric concrete, and to areas specified by the manufacturer.

Prepare, batch, and place the elastomeric concrete in accordance with the manufacturer's instructions. Place the elastomeric concrete in the areas specified on the plans while the primer is still tacky and within 2 hours after applying the primer. Trowel the elastomeric concrete to a smooth finish.

The joint opening in the elastomeric concrete shall match the formed opening in the concrete deck prior to sawing the joint.

#### **5.0 FIELD SAMPLING**

Provide additional production material to allow freshly mixed elastomeric concrete to be sampled for acceptance. A minimum of six 2-inch cube molds and three 3x6 inch cylinders will be taken by the Department for each day's production. Compression, splitting tensile, and durometer hardness testing will be performed by the Department to determine acceptance. Materials failing to meet the requirements listed above are subject to removal and replacement at no cost to the Department.

# BP-23

Project I-5793

Davidson County

## 6.0 BASIS OF PAYMENT

*Elastomeric Concrete* will be measured and paid for at the contract unit price bid per cubic foot and will be full compensation for furnishing and placing the Elastomeric Concrete.

<b>Pay Item</b>	<b>Pay Unit</b>
Elastomeric Concrete	Cubic Feet

## FOAM JOINT SEALS

(9-27-12)

### 1.0 SEALS

Use preformed seals compatible with concrete and resistant to abrasion, oxidation, oils, gasoline, salt and other materials that are spilled on or applied to the surface. Use a resilient, UV stable, preformed, impermeable, flexible, expansion joint seal. The joint seal shall consist of low-density, closed cell, cross-linked polyethylene non-extrudable, foam. The joint seal shall contain no EVA (Ethylene Vinyl Acetate). Cell generation shall be achieved by being physically blown using nitrogen. No chemical blowing agents shall be used in the cell generation process.

Use seals manufactured with grooves 1/8"± wide by 1/8"± deep and spaced between 1/4" and 1/2" apart along the bond surface running the length of the joint. Use seals with a depth that meets the manufacturer's recommendation, but is not less than 70% of the uncompressed width. Provide a seal designed so that, when compressed, the center portion of the top does not extend upward above the original height of the seal by more than 1/4". Provide a seal that has a working range of 30% tension and 60% compression and meets the requirements given below.

TEST	TEST METHOD	REQUIREMENT
Tensile strength	ASTM D3575-08, Suffix T	110 – 130 psi
Compression Set	ASTM D1056 Suffix B, 2 hr recovery	10% - 16%
Water Absorption	ASTM D3575	< 0.03 lb/ft <sup>2</sup>
Elongation at Break	ASTM D3575	180% - 210%
Tear Strength	ASTM D624 (D3575-08, Suffix G)	14 – 20 pli
Density	ASTM D3575-08, Suffix W, Method A	1.8 – 2.2 lb/ft <sup>3</sup>
Toxicity	ISO-10993.5	Pass (not cytotoxic)

Have the top of the joint seal clearly shop marked. Inspect the joint seals upon receipt to ensure that the marks are clearly visible before installation.

## 2.0 BONDING ADHESIVE

Use a two component, 100% solid, modified epoxy adhesive supplied by the joint seal manufacturer that meets the requirements given below.

TEST	TEST METHOD	REQUIREMENT
Tensile strength	ASTM D638	3000 psi (min.)
Compressive strength	ASTM D695	7000 psi (min.)
Hardness	Shore D Scale	75-85 psi
Water Absorption	ASTM D570	0.25% by weight max.
Elongation to Break	ASTM D638	5% (max.)
Bond Strength	ASTM C882	2000 psi (min.)

Use an adhesive that is workable to 40°F. When installing in ambient air or surface temperatures below 40°F or for application on moist, difficult to dry concrete surfaces, use an adhesive specified by the manufacturer of the joint seal.

## 3.0 SAWING THE JOINT

The joint opening shall be initially formed to the width shown on the plans including the blockout for the elastomeric concrete.

The elastomeric concrete shall have sufficient time to cure such that no damage can occur to the elastomeric concrete prior to sawing to the final width and depth as specified in the plans.

When sawing the joint to receive the foam seal, always use a rigid guide to control the saw in the desired direction. To control the saw and to produce a straight line as indicated on the plans, anchor and positively connect a template or a track to the bridge deck. Do not saw the joint by visual means such as a chalk line. Fill the holes used for holding the template or track to the deck with an approved, flowable non-shrink, non-metallic grout.

Saw cut to the desired width and depth in one or two passes of the saw by placing and spacing two metal blades on the saw shaft to the desired width for the joint opening.

The desired depth is the depth of the seal plus 1/4" above the top of the seal plus approximately 1" below the bottom of the seal. An irregular bottom of sawed joint is permitted as indicated on the plans. Grind exposed corners on saw cut edges to a 1/4" chamfer.

Saw cut a straight joint, centered over the formed opening and to the desired width specified in the plans. Prevent any chipping or damage to the sawed edges of the joint.

Remove any staining or deposited material resulting from sawing with a wet blade to the satisfaction of the Engineer.

**4.0 PREPARATION OF SAWED JOINT FOR SEAL INSTALLATION**

The elastomeric concrete shall cure a minimum of 24 hours prior to seal installation.

After sawing the joint, the Engineer will thoroughly inspect the sawed joint opening for spalls, popouts, cracks, etc. All necessary repairs will be made by the Contractor prior to blast cleaning and installing the seal.

Clean the joints by sandblasting with clean dry sand immediately before placing the bonding agent. Sandblast the joint opening to provide a firm, clean joint surface free of curing compound, loose material and any foreign matter. Sandblast the joint opening without causing pitting or uneven surfaces. The aggregate in the elastomeric concrete may be exposed after sandblasting.

After blasting, either brush the surface with clean brushes made of hair, bristle or fiber, blow the surface with compressed air, or vacuum the surface until all traces of blast products and abrasives are removed from the surface, pockets, and corners.

If nozzle blasting is used to clean the joint opening, use compressed air that does not contain detrimental amounts of water or oil.

Examine the blast cleaned surface and remove any traces of oil, grease or smudge deposited in the cleaning operations.

Bond the seal to the blast cleaned surface on the same day the surface is blast cleaned.

**5.0 SEAL INSTALLATION**

Install the joint seal according to the manufacturer's procedures and recommendations and as recommended below. Do not install the joint seal if the ambient air or surface temperature is below 45°F. Have a manufacturer's certified trained factory representative present during the installation of the first seal of the project.

Before installing the joint seal, check the uninstalled seal length to insure the seal is the same length as the deck opening. When the joint seal requires splicing, use the heat welding method by placing the joint material ends against a teflon heating iron of 425-475°F for 7 - 10 seconds, then pressing the ends together tightly. Do not test the welding until the material has completely cooled.

Begin installation by protecting the top edges of the concrete deck adjacent to the vertical walls of the joint as a means to minimize clean up. After opening both cans of the bonding agent, stir each can using separate stirring rods for each component to prevent premature curing of the bonding agent. Pour the two components, at the specified mixing ratio, into a clean mixing bucket. Mix the components with a low speed drill (400 rpm max.) until a uniform gray color is achieved without visible marbling. Apply bonding agent to both sides of the elastomeric concrete as well as both sides of the joint seal, making certain to completely fill the grooves with epoxy. With gloved hands, compress the joint seal and with

the help of a blunt probe, push the seal into the joint opening until the seal is recessed approximately 1/4" below the surface. When pushing down on the joint seal, apply pressure only in a downward direction. Do not push the joint seal into the joint opening at an angle that would stretch the material. Seals that are stretched during installation shall be removed and rejected. Once work on placing a seal begins, do not stop until it is completed. Clean the excess epoxy from the top of the joint seal immediately with a trowel. Do not use solvents or any cleaners to remove the excess epoxy from the top of the seal. Remove the protective cover at the joint edges and check for any excess epoxy on the surface. Remove excess epoxy with a trowel, the use of solvents or any cleaners will not be allowed.

The installed system shall be watertight and will be monitored until final inspection and approval. Do not place pavement markings on top of foam joint seals.

## **6.0 BASIS OF PAYMENT**

Payment for all foam joint seals will be at the lump sum contract price bid for "Foam Joint Seals". Prices and payment will be full compensation for furnishing all material, including elastomeric concrete, labor, tools and equipment necessary for installing these units in place and accepted.

## **PAINTING EXISTING WEATHERING STEEL STRUCTURE**

**(12-5-12)**

### **DESCRIPTION**

This work shall consist of furnishing all labor, equipment, and materials necessary to clean and paint the weathering steel of the existing structure. Work includes: removal, containment and disposal of the existing paint system; preparation of the surface to be painted and applying the new paint system; a containment enclosure; and any incidentals necessary to complete the project as specified and shown on the plans.

### **CERTIFICATION**

Only contractors who are currently SSPC QP 1 certified, and have successfully completed field painting on similar structures within 18 months prior to this bid, may perform this work.

Successfully completed projects shall have all lead abatement work completed in accordance with the contract and be free of citation from safety or environmental agencies. Lead abatement work shall include, but not be limited to: abrasive blasting; waste handling, storage and disposal; worker safety during lead abatement activities (fall protection, PPE, etc.); and containment. This requirement is in addition to the Contractor pre-qualification requirements covered by Article 102-2 of the *2018 Standard Specifications*.

### **TWELVE-MONTH OBSERVATION PERIOD**

The Contractor maintains responsibility for the coating system for a 12 month observation period beginning upon the satisfactory completion of all the work required in the plans or as

# BP-27

Project I-5793

Davidson County

directed by the Engineer. The Contractor shall guarantee the coating system under the payment and performance bond (refer to Article 109-10 of the *2018 Standard Specifications*). To successfully complete the observation period, the coating system shall meet the following requirements after 12 months service:

- (A) No visible rust, contamination or application defect is observed in any coated area.
- (B) Painted surfaces have a uniform color and gloss.
- (C) Painted surfaces have an adhesion that meets an ASTM D3359, 3A rating.

Final acceptance is made only after the paint system meets the above requirements.

## SUBMITTALS

Submit all of the following to the Engineer for review and approval before scheduling the pre-construction meeting. Allow at least 2 weeks for the review process.

- (A) Work schedule which shall be kept up to date, with a copy of the revised schedule being provided to the Engineer in a timely manner,
- (B) Containment Drawings in accordance with SSPC Guide 6, Class 3A sealed by a Professional Engineer licensed by the State of North Carolina,
- (C) Bridge wash water sampling and disposal plan,
- (D) Subcontractor identification,
- (E) Lighting plan for night work in accordance with Section 1413 of the *2018 Standard Specifications*,
- (F) Traffic control plan with NCDOT certified supervisors, flaggers and traffic control devices,
- (G) Health and Safety Plan addressing at least the required topics as specified by the SSPC QP 1 program which includes, but is not limited to: hazardous materials, personal protective equipment, hand and power tools, ladders, toxic and hazardous substances, emergency procedures, and local hospital and treatment facilities with directions and phone numbers, disciplinary criteria for workers who violate the plan and accident investigation,
- (H) Provide the Engineer with Competent Person qualifications and summary of work experience.
- (I) Environmental Compliance Plan
- (J) Quality Control Plan (Project Specific) with quality control qualifications and summary of work experience.
- (K) Bridge and Public Protection Plan (Overspray, Utilities, etc. - Project/Task Specific)
- (L) Abrasive Blast Media
  - (1) Product Data Sheet
  - (2) Blast Media Test Reports in accordance with Article 1080-12 of the *2018 Standard Specification*.
- (M) Coating Material
  - (1) NCDOT HICAMS Test Reports (testing performed by NCDOT Materials and Tests Unit),
  - (2) Product Data Sheets,
  - (3) Material Safety Data Sheets,

- (4) Product Specific Repair Procedures, and
- (5) Acceptance letters from paint manufacturer's for work practices that conflict with Project Special Provisions and/or paint manufactures product data sheets.

**PRE-CONSTRUCTION MEETING**

Submittals shall be reviewed and approved by the Engineer prior to scheduling the pre-construction meeting. Allow no less than 2 weeks for a review process. When requesting a pre-construction meeting, contact the Engineer at least 7 working days in advance of the desired pre-construction date. The contractor's project supervisor, Competent person, quality control personnel and certified traffic control supervisor shall be in attendance at the pre-construction meeting in order for the Contractor and NCDOT team to establish responsibilities for various personnel during project duration and to establish realistic timeframes for problem escalation.

**CONTAINMENT PLAN FOR WEATHERING STEEL**

The containment plan shall meet Class 3A containment in accordance with SSPC Guide 6. Enclosure drawings and loads supported by the structure shall be prepared, signed and sealed by a Professional Engineer licensed by the State of North Carolina. Describe what physical containment will be provided during painting application to protect the public and areas not to be painted. Protect non-metallic parts of bearings from blasting and painting (i.e.: Pot Bearings, Elastomeric Pads, and Disc Bearings).

**WASH WATER SAMPLING AND DISPOSAL PLAN**

No work begins until the Contractor furnishes the Engineer with a containment plan for surface preparation and coating operations and the Engineer reviews and approves in writing said plan. All wash water shall be collected and sampled prior to disposal. Representative sampling and testing methodology shall conform to 15A NCAC 02B.0103, "Analytical Procedures". Wash water shall be tested for pollutants listed in 15A NCAC 02B.0211(3), 15A NCAC 02T.0505(b)(1) and 15A NCAC 2T.0905(h). Depending on the test results, wash water disposal methods shall be described in the disposal plan. Wash water shall be disposed of in accordance with all current Federal and State regulations. See link for NCDOT Guidelines for Managing Bridge Wash Water: <http://www.ncdot.gov/projects/ncbridges/#stats>.

**WASTE HANDLING OF PAINT AND ABRASIVES**

Comply with all Federal, State and local regulations. Failure to comply with the regulations could result in fines and loss of qualified status with NCDOT.

Comply with the Resource Conservation and Recovery Act (RCRA - 40 CFR 261 - 265) and the Occupational Safety and Health Act (OSHA - 29 CFR 1910 - 1926) regulations for employee training, and for the handling, storage, labeling, recordkeeping, reporting,



# BP-29

Project I-5793

Davidson County

inspections and disposal of all hazardous waste generated during paint removal. All waste, hazardous or non-hazardous, requires numbered shipping manifests.

Comply with the NCDENR Hazardous Waste Compliance Manual for Generators of Hazardous Waste. Record quantities of waste by weight and dates of waste generation. Until test results are received, store all waste, and label as “NCDOT Bridge Paint Removal Waste - Pending Analysis” and include the date generated and contact information for the Division HazMat Manager or Project Engineer. Store waste containers in an enclosed, sealed and secured storage container protected from traffic from all directions. Obtain approval for the protection plan for these containers from the Engineer. If adequate protection cannot be obtained by use of existing guardrail, provide the necessary supplies and equipment to maintain adequate protection. Once test results are received and characterized, label waste as either “Hazardous Waste - Pending Disposal” or “Paint Waste - Pending Disposal”.

The North Carolina Department of Environment and Natural Resources (NCDENR) adopted RCRA as the North Carolina Hazardous Waste Management Rules and is responsible for enforcement. The “Hazardous Waste Compliance Manual for Generators of Hazardous Waste” is published by the Compliance Branch of the Division of Waste Management of NCDENR and can be found at <http://portal.ncdenr.org/web/wm/hw/rules>.

If waste is considered hazardous, the following applies:

Use a company from the below list of approved waste management companies. Immediately after award of the contract, arrange for waste containers, sampling, testing, transportation and disposal of all waste. No work shall begin until the Contractor furnishes the Engineer with a written waste disposal plan. Any alternative method for handling waste shall be pre-approved by the Engineer.

Southern Logistics, Inc. – 312 Orville Wright Dr., Greensboro, NC 27409  
(Ph. 336-662-0292)

A&D Environmental – PO Box 484, High Point, NC 27261  
(Ph. 336-434-7750)

Poseidon Environmental Services, Inc. – 837 Boardman-Canfield Rd #209, Youngstown, OH  
(Ph. 330-726-1560)

Clean Harbors Reidsville, LLC – 208 Watlington Industrial Drive, Reidsville, NC 27320  
(Ph. 336-342-6106)

Test all removed paint and spent abrasive media for lead following the SW-846 TCLP Method 1311 Extraction, as required in 40 CFR 261, Appendix 11, to determine whether it shall be disposed of as hazardous waste. Furnish the Engineer certified test reports showing TCLP results and Iron analysis of the paint chips stored on site, with disposal being in accordance with “Flowchart on Lead Waste Identification and Disposal” at:

[http://portal.ncdenr.org/c/document\\_library/get\\_file?p\\_l\\_id=38491&folderId=328599&name=DLFE-9855.pdf](http://portal.ncdenr.org/c/document_library/get_file?p_l_id=38491&folderId=328599&name=DLFE-9855.pdf).

# BP-30

Project I-5793

Davidson County

All sampling shall be done in presence of the Engineer's representative.

The Competent Person shall obtain composite samples from each barrel of the wash water and waste generated by collecting two or more portions taken at regularly spaced intervals during accumulation. Composite the portions into one sample for testing purposes. Acquire samples after 10% or before 90% of the barrel has accumulated. The intent is to provide samples that are representative of widely separated portions, but not the beginning and end of wash water or waste accumulation.

Perform sampling by passing a receptacle completely through the discharge stream or by completely diverting the discharge into a sample container. If discharge of the wash water or waste is too rapid to divert the complete discharge stream, discharge into a container or transportation unit sufficiently large to accommodate the flow and then accomplish the sampling in the same manner as described above.

Once the waste has been collected, and the quantities determined, prepare the appropriate shipping documents and manifests and present them to the Engineer. The Engineer will verify the type and quantity of waste and obtain a Provisional EPA ID number from the:

NC Hazardous Waste Section  
North Carolina Department of Environment & Natural Resources  
1646 Mail Service Center  
Raleigh, NC 27699  
Phone (919) 508-8400, Fax (919) 715-4061

At the time of shipping, the Engineer will sign, date and add the ID number in the appropriate section on the manifest. The maximum on-site storage time for collected waste shall be 90 days. All waste whether hazardous or non-hazardous will require numbered shipping manifests. The cost for waste disposal (including lab and Provisional EPA ID number) is included in the bid price for this contract. Note NC Hazardous Waste Management Rules (15A NCAC 13A) for more information. Provisional EPA ID numbers may be obtained at this link:

<http://portal.ncdenr.org/web/wm/provisional-hw-notification-page>.

Testing labs shall be certified in accordance with North Carolina State Laboratory Public Health Environmental Sciences. List of certified laboratories may be obtained at this link:

<http://slphreporting.ncpublichealth.com/EnvironmentalSciences/Certification/CertifiedLaboratory.asp>.

All test results shall be documented on the lab analysis as follows:

1. For leachable lead:
  - a. Soils/Solid/Liquid- EPA 1311/200.7/6010

Area sampling will be performed for the first 2 days at each bridge location. The area sample will be located within five feet of the containment and where the highest probability of leakage will occur (access door, etc.). Results from the area sampling will be given to the Engineer within 72 hours of sampling (excluding weekends). If the results of the samples exceed  $20 \mu\text{g}/\text{m}^3$  corrective measures shall be taken and monitoring shall be continued until 2 consecutive sample results are less than  $20 \mu\text{g}/\text{m}^3$ .

TWA may suspend the work if there are visible emissions outside the containment enclosure or pump monitoring results exceeding the level of  $30 \mu\text{g}/\text{m}^3$ .

Where schools, housing and/or buildings are within 500 feet of the containment, the Contractor shall perform initial TSP-Lead monitoring for the first 10 days of the project during abrasive blasting, vacuuming and containment removal. Additional monitoring will be required during abrasive blasting 2 days per month thereafter. Results of the TSP monitoring at any location shall not exceed  $1.5 \mu\text{g}/\text{m}^3$ .

## **EQUIPMENT MOBILIZATION**

The equipment used in any travel lanes and paved shoulder shall be mobile equipment on wheels that has the ability to move on/off the roadway in less than 30 minutes. All work conducted in travel lanes shall be from truck or trailer supported platforms and all equipment shall be self-propelled or attached to a tow vehicle at all times.

## **QUALITY CONTROL INSPECTOR**

Provide a quality control inspector in accordance with the SSPC QP guidelines to ensure that all processes, preparation, blasting and coating application are in accordance with the requirements of the contract. The inspector shall have written authority to perform QC duties to include continuous improvement of all QC internal procedures. The presence of the engineer or inspector at the work site shall in no way lessen the contractor's responsibility for conformity with the contract.

## **QUALITY ASSURANCE INSPECTOR**

The quality assurance inspector which may be a Department employee or a designated representative of the Department shall observe, document, assess and report that the Contractor is complying with all of the requirements of the contract. Inspectors employed by the Department are authorized to inspect all work performed and materials furnished. Such inspection may extend to all or any part of the work and to the preparation, fabrication or manufacture of the materials to be used. The inspector is not authorized to alter or waive the requirements of the contract. Each stage in preparing the structure to be

# BP-32

Project I-5793

Davidson County

coated which includes but not limited to washing, blasting, coating testing and inspection shall be inspected and approved by the Engineer or his authorized representative.

## **SUBLETTING OF CONTRACT**

Only contractors certified to meet SSPC QP 1 and have successfully completed field painting on similar structures within 18 months prior to this bid are qualified for this work. Work is only sublet by approval of the Engineer.

## **PREPARATION OF SURFACES**

Before any other surface preparation is conducted, all surfaces shall be power washed to remove dust, salts, dirt and other contaminants. All wash water shall be contained, collected and tested in accordance with the requirements of NCDOT Managing Bridge Wash Water specification. Obtain approval of the Engineer and allow all cleaned surfaces to dry to the touch and without standing water before beginning surface preparation or painting activities.

Surface preparation is done with materials meeting Article 1080-12 of the *2018 Standard Specifications*. No silica sand or other silica materials are permitted for use. The profile shall be between 1.0 and 3.0 mils when measured on a smooth steel surface. Conduct and document at least 2 tests per beam/girder and 2 tests per span of diaphragms/cross bracing.

Spread tarpaulins over all pavements and surfaces underneath equipment used for abrasive blasting as well as equipment and containers used to collect abrasive media. This requirement will be enforced during activity and inactivity of equipment.

Before the Contractor departs from the work site at the end of the work day, collect all debris generated during surface preparation and all dust collector hoses, tarps or other appurtenances containing blasting residue in approved containers.

Clean a 3" x 3" area at each structure to demonstrate the specified finish, and the inspector will preserve this area by covering it with tape, plastic or some other suitable means so that it can be retained as the Dry Film Thickness (DFT) gauge adjustment standard. An acceptable alternative is for the Contractor to provide a steel plate with similar properties and geometry as the substrate to be measured.

The contractor and or quality assurance representative shall notify the Engineer of any area of corroded steel which has lost more than 50% of its original thickness.

All parts of the bridges not to be painted and the travelling public shall be protected from overspray. Submit a plan to protect all parts of bridge that are not required to be painted and a plan to protect the traveling public and surrounding environment while applying all coats of paint to a structure.

Ensure that chloride levels on the surfaces are  $7 \mu\text{g}/\text{cm}^2$  or lower using an acceptable sample method in accordance with SSPC Guide 15. The frequency of testing shall be 2 tests per span after all surface preparation has been completed and immediately prior to painting.

# BP-33

Project I-5793

Davidson County

Select test areas representing the greatest amount of corrosion in the span as determined by the Engineers' representative. Additional testing may be required if significant amounts of chloride are detected.

All weld splatter, slag or other surface defects resulting in a raised surface above the final paint layer shall be removed prior to application of primer coat.

## PAINTING OF STEEL

Comply with Article 442-4 of the *2018 Standard Specifications*. System 4 modified is an epoxy organic zinc and acrylic topcoats used over blast cleaned surfaces in accordance with SSPC SP-6. Field painting consists of applying primer and finish paints at the ends of beams and girders within a distance of 1.5 times the depth of the beam or girder at the bearing, except as otherwise stated. Paint terminations on all fascia beams and girders to provide a neat and straight line appearance with no overspray present.

Perform all mixing operations over an impervious surface with provisions to prevent runoff to grade of any spilled material. The Contractor is responsible for reporting quantities of thinner purchased as well as the amounts used. No container with thinner shall be left uncovered, when not in use.

Apply 2" stripe coat, by brush or roller only, to all exposed edges of steel including fasteners before applying the finish coat. Locate the edge or corner in the approximate center of the paint stripe.

Any area where newly applied paint fails to meet the specifications shall be repaired or replaced by the Contractor. The Engineer approves all repair processes before the repair is made. Repaired areas shall meet the Specifications. The Contractor applies an additional finish coat of paint to areas where the tape adhesion test is conducted.

## MATERIALS

Only paint suppliers that have a NCDOT qualified organic zinc primer may furnish paints for this project. All paints applied to a structure shall be from the same supplier. Before any paints are applied the Contractor shall provide the Engineer a manufacturer's certification that each batch of paint meets the applicable requirements of Section 1080 of the *2018 Standard Specifications*.

The inspector randomly collects a one pint sample of each paint product used on the project. Additional samples may be collected as needed to verify compliance to the specifications.

Do not expose paint materials to rain, excessive condensation, long periods of direct sunlight, or temperatures above 110°F or below 40°F. In addition, the Contractor shall place a device which records the high, low and current temperatures inside the storage location. Follow the manufacturer's storage requirements if more restrictive than the above requirements.

## INSPECTION

Surface Preparation for System 4 modified shall be in accordance with SSPC SP-6. Any area(s) not meeting SSPC SP-6 shall be remediated prior to application of coating. Surface inspection is considered ready for inspection when all blast abrasive, residue and dust is removed from surfaces to be coated.

### (A) Quality Assurance Inspection

The Contractor furnishes all necessary OSHA approved apparatus such as ladders, scaffolds and platforms as required for the inspector to have reasonable and safe access to all parts of the work. The contractor illuminates the surfaces to be inspected to a minimum of 50-foot candles of light. All access points shall be illuminated to a minimum of 20-foot candles of light.

NCDOT reserves the right for ongoing QA (Quality Assurance) inspection to include but not limited to surface contamination testing, adhesion pull testing and DFT readings as necessary to assure quality.

Inform the Engineer and the Division Safety Engineer of all scheduled and unannounced inspections from SSPC, OSHA, EPA and/or others that come on site. Furnish the Engineer a copy of all inspection reports except for reports performed by a third party and or consultant on behalf of the Contractor.

### (B) Inspection Instruments

At a minimum, furnish the following calibrated instruments and conduct the following quality control tests:

- (1) Sling Psychrometer - ASTM E337 - bulb type
- (2) Surface Temperature Thermometer
- (3) Wind Speed Indicator
- (4) Tape Profile Tester - ASTM D4417 Method C
- (5) Surface Condition Standards - SSPC VIS-1 and VIS-3
- (6) Wet Film Thickness Gage - ASTM D4414
- (7) Dry Film Thickness Gage - SSPC-PA2 Modified
- (8) Pencil Hardness Test - ASTM D3363
- (9) Adhesion Test Kit - ASTM D3359 Method A (Tape Test)
- (10) Adhesion Pull test - ASTM D4541
- (11) Surface Contamination Analysis Kit or (Chloride Level Test Kit)  
SSPC Technology Guide 15

### (C) Quality Control

Maintain a daily quality control record in accordance with Article 442-12(D) of the *2018 Standard Specifications* and make such records available at the job site for

# BP-35

Project I-5793

Davidson County

review by the inspector and submit to the Engineer as directed. In addition to the information required on M&T-610, submit all Dry Film Thickness (DFT) readings on a form equivalent to M&T-611.

Measure DFT at each spot on the attached diagram and at the required number of locations as specified below:

- (1) For span members with a height 36" or less check two (2) random locations along each member in each span.
- (2) For span members with a height 36" or greater check three (3) random locations along each member in each span.

Stiffeners and other attachments to beams and or plate girders shall be measured at no less than two random spots per span. Also dry film thickness is measured at no less than two random spots per span on diaphragms/"K" frames.

Each spot is an average of three to five individual gauge readings as defined in SSPC PA-2. No spot average shall be less than 80% of minimum DFT for each layer applied; this does not apply to stripe coat application. Spot readings that are nonconforming shall be re-accessed by performing additional spot measurements not to exceed one foot intervals on both sides of the low areas until acceptable spot averages are obtained. These non-conforming areas shall be corrected by the Contractor prior to applying successive coats.

# BP-36

**Less than 36" in height and/or bottom flanges less than 16" in width.**

**7 Spot Areas**  
**21 Individual DFT Readings**

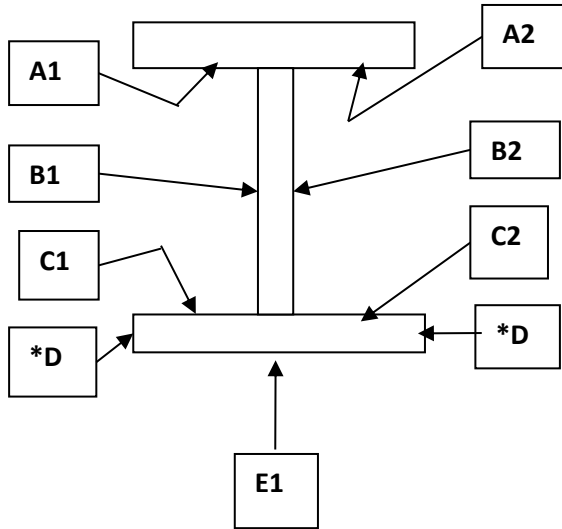

**\*D areas are only included when flange thickness is one inch (1") or greater.**

**36" in height or greater and/or bottom flanges greater than 16" in width.**

**10 Spot Areas**  
**30 Individual DFT Readings**

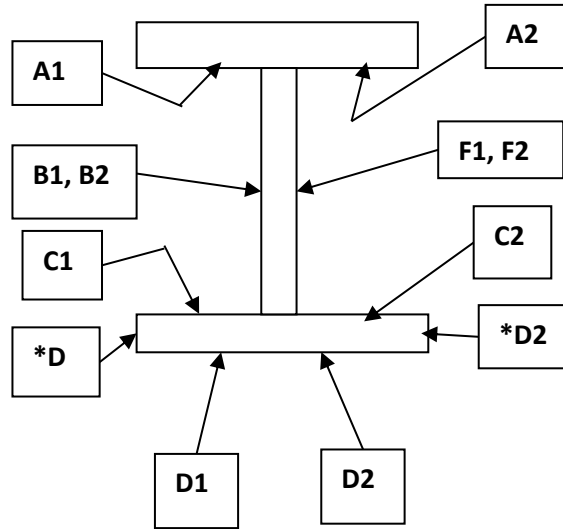

**\*D areas are only included when flange thickness is one inch (1") or greater.**

Two random adhesion tests (1 test=3 dollies) per span are conducted on interior surfaces in accordance with ASTM D4541 (Adhesion Pull Test) after the prime coat has been properly cured in accordance with ASTM D3363 (Pencil Hardness) with no less than 2H, and will be touched up by the Contractor. The required minimum average adhesion is 400 psi.

Cure of the intermediate and stripe coats shall be assessed by using the thumb test in accordance with ASTM D1640 (Curing Formation Test) prior to the application of any successive layers of paint.

One random Cut Tape adhesion test per span is conducted in accordance with ASTM D3359 (X-Cut Tape Test) on interior surface after the finish coat is cured. Repair areas shall be properly tapered and touched up by the Contractor.



## **SAFETY AND ENVIRONMENTAL COMPLIANCE PLANS**

Personnel access boundaries are delineated for each work site using signs, tape, cones or other approved means. Submit copies of safety and environmental compliance plans that comply with SSPC QP 1 Certification requirements.

## **HEALTH AND SAFETY RESPONSIBILITIES**

This project may involve toxic metals such as arsenic, lead, cadmium and hexavalent chromium. It is the contractor's responsibility to test for toxic metals and if found, comply with the OSHA regulations, which may include medical testing.

Ensure a "Competent Person" as defined in OSHA 29 CFR 1926.62; one who is capable of identifying existing and predictable hazards in the surroundings or working conditions which are unsanitary, hazardous, or dangerous to employees, and who has authorization to take prompt corrective measures to eliminate them; is on site during all surface preparation activities and monitors the effectiveness of containment, dust collection systems and waste sampling. Before any work begins, provide a written summary of the Competent Person's safety training.

Comply with Subarticle 442-14(B) of the *2018 Standard Specifications*.

Comply with Subarticle 442-14(D) of the *2018 Standard Specifications*. Ensure employee blood sampling test results are less than 50 micrograms per deciliter. Remove employees with a blood sampling test of 50 or more micrograms per deciliter from work activities involving any lead exposure.

An employee who has been removed with a blood level of 50 micrograms per deciliter or more shall have two consecutive blood sampling tests spaced one week apart indicating that the employee's blood lead level is at or below 40 micrograms per deciliter before returning to work activities involving any lead exposure.

All OSHA recordable accidents that occur during the project duration are to be reported to the Engineer within twenty-four (24) hours of occurrence. In addition, for accidents that involve civilians or property damage that occurs within the work zone the Division Safety Engineer shall be notified immediately.

Prior to blasting operations, the Contractor shall have an operational OSHA approved hand wash station at each bridge location and a decontamination trailer at each bridge or between bridges unless the work is on the roadway, or the Contractor shall show reason why it is not feasible to do so and provide an alternative site as approved by the Engineer. The Contractor shall assure that all employees whose airborne exposure to lead is above the PEL shall shower at the end of their work shift.

## **STORAGE OF PAINT AND EQUIPMENT**

Provide a location for materials, equipment and waste storage. Spread tarpaulins over all pavements and surfaces underneath equipment used for abrasive recycling and other waste

# BP-38

Project I-5793

Davidson County

handling equipment or containers. All land and or lease agreements that involve private property shall disclose to the property owner that heavy metals may be present on the Contractor's equipment. Prior to storing the Contractor's equipment on private property, provide a notarized written consent signed by the land owner received by the Engineer at least forty-eight (48) hours before using property. All storage of paint, solvents and other materials applied to structures shall be stored in accordance with Section 442 of the *2018 Standard Specifications* or the manufacturers' requirements. The more restrictive requirements will apply.

## UTILITIES

Protect all utility lines or mains which may be supported on, under, or adjacent to bridge work sites from damage and paint overspray.

## MEASUREMENT AND PAYMENT

The cost of inspection, surface preparation and repainting the existing structure is included in the lump sum price bid for *Painting Existing Weathering Steel Structure for Bridge No. \_\_\_*. This price is full compensation for furnishing all inspection equipment, all paint, cleaning abrasives, cleaning solvents and all other materials; preparing and cleaning surfaces to be painted; applying paint in the field; protecting work area, traffic and property; and furnishing blast cleaning equipment, paint spraying equipment, brushes, rollers, any other hand or power tools and any other equipment; and a containment enclosure.

*Pollution Control* will be paid at the contract lump sum price which will be full compensation for all collection, handling, storage, air monitoring, and disposal of debris and wash water, all personal protective equipment, and all personal hygiene requirements, and all equipment, material and labor necessary for the daily collection of the blast debris into specified containers; and any measures necessary to ensure conformance to all safety and environmental regulations as directed by the Engineer.

Payment will be made under:

<b>Pay Item</b>	<b>Pay Unit</b>
Painting Existing Weathering Steel Structure for Bridge No. ___	Lump Sum
Pollution Control	Lump Sum

**DESCRIPTION OF BRIDGES**

**Bridge No. 479:** This bridge was built in 1981 and carries I-85 NBL over NC 109 (Randolph Street). The superstructure consist of 3 simple spans with 8 lines of steel I-beams @ 7'-6" spacing with steel cross frames. Spans A & C consist of W27 x 84 steel I beam and Span B consists of steel plate girders with a 57" web depth and 11" top flange width and 13" bottom flange width. The bridge has an overall length of 168'-9" with a concrete deck and a 58'-10" total deck width. The minimum vertical clearance is 18'-10". The existing paint system is weathering steel, and the estimated area to be cleaned and painted is **5,029** sq. ft.

**Bridge No. 480:** This bridge was built in 1981 and carries I-85 SBL over NC 109 (Randolph Street). The superstructure consist of 3 simple spans with 8 lines of steel I-beams @ 7'-6" spacing with steel cross frames. Spans A & C consist of W27 x 84 steel I beam and Span B consists of steel plate girders with a 57" web depth and 11" top flange width and 13" bottom flange width. The bridge has an overall length of 166'-6" with a concrete deck and a 58'-10" total deck width. The minimum vertical clearance is 16'-7". The existing paint system is weathering steel, and the estimated area to be cleaned and painted is **5,029** sq. ft.

**Bridge No. 485:** This bridge was built in 1981 and carries I-85 NBL over I-85 SBL. The superstructure consists of 3 simple spans with 8 lines of steel plate girders @ 7'-8" spacing with steel cross frames. Spans A & C consist of tapered steel plate girders with min. 48" and max. 88.625" web depth and 12" top and bottom flange width. Span B consists of steel plate girders with a 87" web depth and 12" top flange width and 18" bottom flange width. The bridge has an overall length of 285'-0" with a concrete deck and a 58'-10" total deck width. The minimum vertical clearance is 16'-8". The existing paint system is weathering steel, and the estimated area to be cleaned and painted is **11,226** sq. ft.

**Bridge No. 489:** This bridge was built in 1981 and carries SR 2085 (Lake Road) over I-85. The superstructure consists of 4 simple spans with 10 lines of steel plate girders @ 7'-8" spacing with steel cross frames. Spans A and D consist of steel plate girders with a 36" minimum web depth and 48" maximum web depth, 10" top flange width, and 10" bottom flange width. Spans B and C consist of steel plate girders with a 48" web depth, 12" top flange width, and 16" bottom flange width. The bridge has an overall length of 268'-0" with a concrete deck and a 74'-10" total deck width. The minimum vertical clearance is 16'-9". The existing paint system is weathering steel, and the estimated area to be cleaned and painted is **7,725** sq. ft.

# BP-40

Project I-5793

Davidson County

**Bridge No. 493:** This bridge was built in 1981 and carries I-85 NBL over Ferndale Drive. The superstructure consists of 3 simple spans with 8 lines of steel I-beams @ 7'-8" spacing with steel cross frames. Spans A and C consist of W36 x 135 steel I-beams. Span B consists of W36 x 210 steel I-beams. The bridge has an overall length of 151'-2" with a concrete deck and a 58'-10" total deck width. The minimum vertical clearance is 18'-5". The existing paint system is weathering steel, and the estimated area to be cleaned and painted is **3,014** sq. ft.

**Bridge No. 494:** This bridge was built in 1981 and carries I-85 SBL over Ferndale Drive. The superstructure consists of 3 simple spans with 8 lines of steel I-beams @ 7'-8" spacing with steel cross frames. Spans A and C consist of W36 x 135 steel I-beams. Span B consists of W36 x 210 steel I-beams. The bridge has an overall length of 169'-5" with a concrete deck and a 58'-10" total deck width. The minimum vertical clearance is 23'-1". The existing paint system is weathering steel, and the estimated area to be cleaned and painted is **3,006** sq. ft.

## **CLEANING AND PAINTING EXISTING BEARINGS WITH HRCSA (SPECIAL)**

### **DESCRIPTION**

These items of work shall consist of cleaning, preparation, and field application of the specified paint system to existing steel bridge bearings and for all labor, materials, tools and equipment necessary, to complete the work to the limits shown on the plans, described in these special provisions, or as directed by the Engineer.

The bridge bearings shall be cleaned using hand tools, power tools, and high pressure water equipment. Using dry compressed air, connections and crevices will be dried completely. Rust penetrant will be applied to all open connections, crevices, pack rust and scale rust areas. A paint system with a co-polymerized high ratio of 'active' calcium sulfonate (HRCSA) will be used as a stripe coat at all connections/crevices and as a topcoat over the bearings.

### **CERTIFICATION**

Only contractors who are currently SSPC QP 1 certified, and have successfully completed field painting on similar structures within 18 months prior to this bid, may perform this work.

Successfully completed projects shall have all lead abatement work completed in accordance with the contract and be free of citation from safety or environmental agencies. Lead abatement work shall include, but not be limited to: abrasive blasting; waste handling, storage and disposal; worker safety during lead abatement activities (fall protection, PPE, etc.); and containment. This requirement is in addition to the Contractor pre-qualification requirements covered by Article 102-2 of the *2018 Standard Specifications*.

## TWELVE-MONTH OBSERVATION PERIOD

The Contractor maintains responsibility for the coating system for a 12 month observation period beginning upon the satisfactory completion of all the work required in the plans or as directed by the Engineer. The Contractor shall guarantee the coating system under the payment and performance bond (refer to Article 109-10 of the *2018 Standard Specifications*). To successfully complete the observation period, the coating system shall meet the following requirements after 12 months service:

- (A) No visible rust, contamination or application defect is observed in any coated area.
- (B) Painted surfaces have a uniform color and gloss.
- (C) Painted surfaces have an adhesion that meets an ASTM D3359, 3A rating.

Final acceptance is made only after the paint system meets the above requirements.

## SUBMITTALS

Submit all of the following to the Engineer for review and approval before scheduling the pre-construction meeting. Allow 40 calendar days for review and approval, or acceptance, of working drawings, from the date they are received, until they are returned by the Engineer.

- (A) Work schedule which shall be kept up to date, with a copy of the revised schedule being provided to the Engineer in a timely manner,
- (B) Containment Drawings in accordance with SSPC Guide 6, Class 3W sealed by a Professional Engineer licensed by the State of North Carolina,
- (C) Bridge wash water sampling and disposal plan,
- (D) Subcontractor identification,
- (E) Lighting plan for night work in accordance with Section 1413 of the *2018 Standard Specifications*. Lighting shall be equipped with explosion-proof fixtures,
- (F) Traffic control plan with NCDOT certified supervisors, flaggers and traffic control devices,
- (G) Health and safety plan addressing at least the required topics as specified by the SSPC QP 1 and QP 2 program and including hazard communication, respiratory health, emergency procedures, and local hospital and treatment facilities with directions and phone numbers, disciplinary criteria for workers who violate the plan and accident investigation. The plan shall address the following: hazardous materials, personal protective equipment, general health and safety, occupational health and environmental controls, fire protection and prevention, signs signals, and barricades, materials handling, storage, use, and disposal, hand and power tools, welding and cutting, electrical, scaffolds, fall protection, cranes, derricks, hoists, elevators, and conveyors, ladders, toxic and hazardous substances, airless injection and HPWJ.
- (H) Provide the Engineer a letter of certification that all employees performing work on the project have blood lead levels that are below the OSHA action level.
- (I) Provide the Engineer with Competent Person qualifications and summary of work experience.
- (J) Environmental Compliance Plan

- (K) Quality Control Plan (Project Specific) with quality control qualifications and summary of work experience.
- (L) Bridge and Public Protection Plan (Overspray, Utilities, etc. - Project/Task Specific)
- (M) Soluble salt removing chemical for use during high pressure water cleaning
  - (1) Product Data Sheet
- (N) Coating Material
  - (1) NCDOT HICAMS Test Reports (testing performed by NCDOT Materials and Tests Unit),
  - (2) Product Data Sheets,
  - (3) Safety Data Sheets,
  - (4) Product Specific Repair Procedures, and
  - (5) Acceptance letters from paint manufacturers for work practices that conflict with Project Special Provisions and/or paint manufactures product data sheets.

**PRE-CONSTRUCTION MEETING**

Submittals shall be reviewed and approved by the Engineer prior to scheduling the pre-construction meeting. Allow no less than 2 weeks for a review process. When requesting a pre-construction meeting, contact the Engineer at least 7 working days in advance of the desired pre-construction date. The contractor's project supervisor, Competent person, quality control personnel, coating manufacturer's representative, and certified traffic control supervisor shall be in attendance at the pre-construction meeting in order for the Contractor and NCDOT team to establish responsibilities for various personnel during project duration and to establish realistic timeframes for problem escalation.

**CONTAINMENT PLAN**

If a containment plan for Painting of Existing Structure is submitted for a bridge that will have its bearings cleaned and painted with HRCSA, the containment plan for that structural steel painting operation will suffice for cleaning and painting existing bearings with HRCSA. If the structural steel of a bridge is not to be cleaned and painted, and no containment plan has been submitted for that bridge, if that bridge will have its bearings cleaned and painted with HRCSA, a containment plan for cleaning and painting existing bearings with HRCSA shall be submitted for review and approval.

No work shall begin until the Contractor furnishes the Engineer with a containment plan for surface preparation and coating operations and the Engineer reviews and approves, in writing, the acceptability of said plan. Allow a minimum of two weeks for review of the plan. Such plan shall meet or exceed the requirements of Class 3W containment in accordance with SSPC Guide 6. Enclosure drawings and loads supported by the containment structure shall be prepared, signed and sealed by a Professional Engineer licensed by the State of North Carolina.

In the containment plan describe how debris is contained and collected. Describe the type of tarpaulin, bracing materials and the maximum designed wind load. Describe the paint and debris collection system. Describe how the airflow inside the containment structure is

designed to meet all applicable OSHA Standards. Describe how wash water will be contained and paint chips separated. Describe how water run-off from rain will be routed by or through the enclosure. Describe what physical containment will be provided during painting application to protect the public and areas not to be painted.

## **WASH WATER SAMPLING AND DISPOSAL PLAN**

No work shall begin until the Contractor furnishes the Engineer with a containment plan for surface preparation and coating operations and the Engineer reviews and approves in writing said plan. All wash water shall be collected and sampled prior to disposal. Representative sampling and testing methodology shall conform to 15A NCAC 02B.0103, "Analytical Procedures". Wash water shall be tested for pollutants listed in 15A NCAC 02B.0211(3), 15A NCAC 02T.0505(b)(1) and 15A NCAC 2T.0905(h). Depending on the test results, wash water disposal methods shall be described in the disposal plan. Wash water shall be disposed of in accordance with all current Federal and State regulations. See link for NCDOT Guidelines for Managing Bridge Wash Water: <http://www.ncdot.gov/projects/nbridges/#stats>.

## **WASTE HANDLING OF PAINT AND DEBRIS**

Comply with all Federal, State and local regulations. Failure to comply with the regulations could result in fines and loss of qualified status with NCDOT.

Comply with the Resource Conservation and Recovery Act (RCRA - 40 CFR 261 - 265) and the Occupational Safety and Health Act (OSHA - 29 CFR 1910 - 1926) regulations for employee training, and for the handling, storage, labeling, recordkeeping, reporting, inspections and disposal of all hazardous waste generated during paint removal.

A summary of Generator Requirements is available at the above NCDOT web link which cites the specific regulations for each Generator category. Quantities of waste by weight and dates of waste generation shall be recorded. Waste stored at the project site shall be properly labeled. All waste, hazardous or non-hazardous, requires numbered shipping manifests.

The North Carolina Department of Environment and Natural Resources (NCDENR) have adopted RCRA as the North Carolina Hazardous Waste Management Rules and are responsible for enforcement. The "Hazardous Waste Compliance Manual for Generators of Hazardous Waste" is published by the Compliance Branch of the Division of Waste Management of NCDENR, and can be found at: <http://portal.ncdenr.org/web/wm/hw/rules>.

Use a company from the below list of approved waste management companies. Immediately after award of the contract, arrange for waste containers, sampling, testing, transportation and disposal of all waste. No work shall begin until the Contractor furnishes the Engineer with a written waste disposal plan. Any alternative method for handling waste shall be pre-approved by the Engineer.

Southern Logistics, Inc.

# BP-44

Project I-5793

Davidson County

312 Orville Wright Dr., Greensboro, NC 27409  
(Phone 336-662-0292)

A&D Environmental

PO Box 484, High Point, NC 27261  
(Phone 336-434-7750)

Poseidon Environmental Services, Inc.

837 Boardman-Canfield Rd #209, Youngstown, OH  
(Phone 330-726-1560)

Clean Harbors Reidsville, LLC

208 Watlington Industrial Drive, Reidsville, NC 27320  
(Phone 336-342-6106)

All removed paint and debris shall be tested for lead following the SW-846 TCLP Method 1311 Extraction, as required in 40 CFR 261, Appendix 11, to determine whether it shall be disposed of as hazardous waste. Furnish the Engineer certified test reports showing TCLP results and Iron analysis of the paint chips stored on site, with disposal in accordance with "Flowchart on Lead Waste Identification and Disposal" at:

[http://portal.ncdenr.org/c/document\\_library/get\\_file?p\\_l\\_id=38491&folderId=328599&name=DLFE-9855.pdf](http://portal.ncdenr.org/c/document_library/get_file?p_l_id=38491&folderId=328599&name=DLFE-9855.pdf).

All sampling shall be done in presence of the Engineer's representative.

The Competent Person shall obtain composite samples from each barrel of the wash water and waste generated by collecting two or more portions taken at regularly spaced intervals during accumulation. Composite the portions into one sample for testing purposes. Acquire samples after 10% or before 90% of the barrel has accumulated. The intent is to provide samples that are representative of widely separated portions, but not the beginning and end of wash water or waste accumulation.

Perform sampling by passing a receptacle completely through the discharge stream or by completely diverting the discharge into a sample container. If discharge of the wash water or waste is too rapid to divert the complete discharge stream, discharge into a container or transportation unit sufficiently large to accommodate the flow and then accomplish the sampling in the same manner as described above.

Comply with the NCDENR Hazardous Waste Compliance Manual for Generators of Hazardous Waste. Record quantities of waste by weight and dates of waste generation. Until test results are received, store all waste, and label as "NCDOT Bridge Paint Removal Waste - Pending Analysis" and include the date generated and contact information for the Division HazMat Manager or Project Engineer. Store waste containers in an enclosed, sealed and secured storage container protected from traffic from all directions. Obtain approval for the protection plan for these containers from the Engineer. If adequate protection cannot be obtained by use of existing guardrail, provide the necessary supplies and equipment to maintain adequate protection. Once test results are received and characterized, label waste as either "Hazardous Waste - Pending Disposal" or "Paint Waste - Pending Disposal".



Once the waste has been collected, and the quantities determined, prepare the appropriate shipping documents and manifests and present them to the Engineer. The Engineer will verify the type and quantity of waste and obtain a Provisional EPA ID number from the:

NC Hazardous Waste Section  
North Carolina Department of Environment & Natural Resources  
1646 Mail Service Center  
Raleigh, NC 27699  
Phone (919) 508-8400, Fax (919) 715-4061

At the time of shipping, the Engineer will sign, date and add the ID number in the appropriate section on the manifest. The maximum on-site storage time for collected waste shall be 90 days. All waste whether hazardous or non-hazardous will require numbered shipping manifests. The cost for waste disposal (including lab and Provisional EPA ID number) is included in the bid price for this contract. Note NC Hazardous Waste Management Rules (15A NCAC 13A) for more information. Provisional EPA ID numbers may be obtained at this link:

<http://portal.ncdenr.org/web/wm/provisional-hw-notification-page>.

Testing labs shall be certified in accordance with North Carolina State Laboratory Public Health Environmental Sciences. List of certified laboratories may be obtained at this link:

<http://slphreporting.ncpublichealth.com/EnvironmentalSciences/Certification/CertifiedLaboratory.asp>.

All test results shall be documented on the lab analysis as follows:

2. For leachable lead:
  - a. Soils/Solid/Liquid- EPA 1311/200.7/6010

Area sampling will be performed for the first 2 days at each bridge location. The area sample will be located within five feet of the containment and where the highest probability of leakage will occur (access door, etc.). Results from the area sampling will be given to the Engineer within 72 hours of sampling (excluding weekends). If the results of the samples exceed  $20 \mu\text{g}/\text{m}^3$  corrective measures shall be taken and monitoring shall be continued until 2 consecutive sample results are less than  $20 \mu\text{g}/\text{m}^3$ .

TWA may suspend the work if there are visible emissions outside the containment enclosure or pump monitoring results exceeding the level of  $30 \mu\text{g}/\text{m}^3$ .

Where schools, housing and/or buildings are within 500 feet of the containment, the Contractor shall perform initial TSP-Lead monitoring for the first 10 days of the project during water cleaning and containment removal. Additional monitoring will be required

# BP-46

Project I-5793

Davidson County

during water cleaning 2 days per month thereafter. Results of the TSP monitoring at any location shall not exceed  $1.5 \mu\text{g}/\text{m}^3$ .

## EQUIPMENT MOBILIZATION

The equipment used in any travel lanes and paved shoulder shall be mobile equipment on wheels that has the ability to move on/off the roadway in less than 30 minutes. All work conducted in travel lanes shall be from truck or trailer supported platforms and all equipment shall be self-propelled or attached to a tow vehicle at all times.

## SUBLETTING OF CONTRACT

Only contractors certified to meet SSPC QP 2, Category A, and have successfully completed lead paint removal and field painting on all similar structures within 18 months prior to this bid are qualified for this work. Work is only sublet by approval of the Engineer.

## MATERIAL

### PENETRANT AND PAINT SYSTEM

The paint system to be used shall be a High Ratio Co-Polymerized Calcium Sulfonate (HRCSA) coating system. Characteristics of submitted products shall meet or exceed those of the requirements listed within this specification.

The structure is to be coated with a High Ratio, Co-Polymerized Calcium Sulfonate (HRCSA) corrosion mitigation system. Any Contractor-proposed coating system shall meet the following requirements:

- a. The proposed coating system shall be an HRCSA coating as defined by these specifications and shall be submitted for approval.
  1. Primer/Topcoat (Minimum 9.5% active sulfonate) must maintain a 9-11 to 1 ratio Total Base Number to Active Sulfonate, i.e., total base number of 85 to 104 to 9.5% Active Sulfonate, as determined by Percent Active Sulfonate Content by Cationic Titration (Hyamine) testing, Procedure No. 817/4.9/T1409A.
  2. Formulations with greater than 27% Alkyd or co-polymer are not valid HRCSA.
  3. Zero VOC, 100% Solids Penetrant/Sealer approved by HRCSA manufacturer (Minimum 15% active sulfonate, a total base number of 135 to 165, must maintain a 9-11 to 1 ratio Active Sulfonate to Total Base Number as determined by Total Base Number Determination testing, Procedure No. 817/4.9/T1401.
- b. The proposed coating system shall be certified in writing by the coating manufacturer that the HRCSA Primer/Topcoat and the HRCSA Penetrant Sealer meets the HRCSA generic specification and has been verified by the testing titration protocols indicated above. The Engineer may choose to perform verification testing using the same protocols on materials delivered to the job site.
- c. The proposed coating formulation shall have independent laboratory tests showing

# BP-47

Project I-5793

Davidson County

that the HRCSA coating, as supplied, has been tested to ASTM D5894 with a 24 hour freeze thaw cycle and has passed a minimum 5000 hours with no rust creepage at the scribe. The manufacturer shall certify that the currently manufactured formulation used is the same as the formulation that was tested, and can supply supporting documentation.

Lighting shall be equipped with explosion-proof fixtures.

The accumulation of empty paint cans, combustibles, and other debris will not be permitted.

MSDS sheets for all materials shall be maintained on file and provided to the Engineer prior to receipt of the material from the manufacturers.

If required, paint shall be mixed with mechanical mixers in accordance with the paint manufacturer's recommendations.

The primer, stripe, and other coats may be thinned only if recommended by the manufacturer, done in compliance with the manufacturer's instructions, approved by the Engineer, and mixed in the presence of the Engineer. If recommended by the manufacturer and approved by the Engineer, a measuring cup, have graduation in ounces, shall be used in the addition of thinner to any paint. No "eye balling" during addition of thinner to paint will be allowed. Paint mixed with thinner by "eye balling" will be subject to rejection by the Engineer as ruined material.

## PENETRANT AND PAINT STORAGE

Do not expose penetrant and paint materials to rain, excessive condensation, long periods of direct sunlight, or temperatures above 100°F or below 40°F. In addition, the Contractor shall place a device which records the high, low, and current temperatures inside the storage location. Follow the manufacturer's storage requirements if more restrictive than the above requirements. Any material found to be damaged or beyond its expiration date shown on the container shall be immediately removed from the project site and will be considered as ruined material.

## TESTING OF PAINT SAMPLES:

Engineer reserves the right to conduct tests of the materials at any time, and any number of times during the period of field painting.

The Engineer will sample the paint(s) being used. A representative size sample of each component of paint(s) at the construction site will be transferred to metal containers, identified, sealed, and certified in the presence of the Contractor.

Tests on paint samples may be performed by the Owner in order to confirm the manufacturer's test results submitted with each batch of material.

If the laboratory test results show that the material being used does not comply with the requirements specified in this Special Provision, the Contractor will be directed to stop painting work and remove non-complying paint; pay for testing; re-paint surfaces coated with rejected paint; or remove rejected paint from previously painted surfaces if, upon re-painting with specified paint, the two coatings are not compatible.

### CONSTRUCTION METHODS

#### CLEANING AND REMOVAL OF PACK RUST

Removal of pack rust shall be done by hand tool cleaning to meet requirements of SSPC-SP 2, or by power tool cleaning to meet requirements of SSPC-SP 3, or a combination of these methods. Any black oxide scale shall be removed, unless otherwise directed by the Engineer. Pay particular attention to crevice areas when removing pack rust and rust scale. Exercise care to avoid nicking or gouging the steel during removal. Remove all rust scale and loose pack rust, followed by high pressure water cleaning.

#### HIGH PRESSURE WATER CLEANING (HPWC)

The structure (or portions of it to be coated) shall be cleaned with water at a minimum pressure of 5,000 psi, at 5 gallons per minute, with a rotating tip, at a maximum 4 inch standoff distance from the steel surface, held as perpendicular to the steel surface as possible.

All water to be used in the surface preparation shall be potable water.

Ambient wash water temperature is allowed; hot water is not necessary.

The wash water shall include a soluble salt removing chemical at a minimum ratio of 100:1 and in compliance with manufacturer recommendations.

Care should be taken to ensure that the potable wash water does not have a level of chloride exceeding 15 ppm when tested. If higher, the level of soluble salt removing chemical should be proportionally increased as per manufactures recommendation.

It should be expected that the surfaces of the steel (and connections) are contaminated with soluble salts (e.g. Chlorides, Sulfates, or Nitrates). Using an acceptable sample method in accordance with SSPC Guide 15, ensure that soluble slat levels on the surfaces do not exceed allowable soluble salt limits listed below:

Chloride - NVC3 3  $\mu\text{g}/\text{cm}^2$

Sulfate - NVS10 10  $\mu\text{g}/\text{cm}^2$

Nitrate - NVN10 10  $\mu\text{g}/\text{cm}^2$

The frequency of testing shall be 2 tests per span after all surface preparation has been completed and immediately prior to painting. Select test areas representing the greatest amount of corrosion in the span as determined by the Engineers' representative. Additional testing may be required if significant amounts of chloride are detected.

The surface cleaning shall meet the requirements of SSPC-WJ4, to remove loose paint and

loose rust. SSPC SP2 or SP3 (hand or power tool cleaning) may be used in inaccessible areas or when water cleaning is not possible.

In some cases, after HPWC, there may be areas of tightly adhered black oxide that were not removed. All black oxide scale shall be removed, unless otherwise directed by the Engineer.

If there is a question of whether all loose paint has been removed, adhesion testing of the remaining "tightly adhered" paint shall be done in accordance with ASTM D 4541-02 Standard Test Method for Pull-Off Strength of Coatings Using Portable Adhesion Testers, with a minimum value of 300 psi.

Care should be taken to ensure all crevice corroded and pack rusted joints connections and corrosion frozen bearings are flushed with water containing a soluble salt removing chemical, at a minimum pressure of 5,000 psi, at 5 gallons per minute, to ensure removal of all loose materials and to flush out any contaminant.

### COMPRESSED AIR DRYING

All joints, connections, and bearings shall be blown dry with clean, dry, oil free, high pressure (100 psi) compressed air, regardless if the areas appear to be dry. Use the white blotter test in accordance with ASTM D4285 to verify the cleanliness of the compressed air used for blowout of "Limited Access" areas and drying. Conduct the test at least once per shift for each compressor system. Sufficient freedom from oil and moisture is confirmed if soiling and/or discoloration are not visible on the paper. If air contamination is evidenced, change filters, clean traps, add moisture separators or filters, or make adjustments as necessary to achieve clean, dry air.

**All surfaces shall be inspected at this point. Surface preparation found to be deficient will be repeated at the Contractor's expense as directed by the Engineer. Once areas are agreed to be satisfactory, the Contractor may proceed with penetrating sealer application.**

### PENETRATING SEALER

Penetrating sealer may be applied by brush, roller, or airless spray method as recommended by the manufacturer. The mixing amount and method of mixing for the sealer components must be in accordance with the manufacturer's instruction. Wet coat sufficiently to completely cover and penetrate the steel surface, but do not apply heavy coat. Use coat thickness as recommended by the manufacturer. Apply liberally to crevices and joints and/or spaces where a gap has been created between plates and around bolts, nuts and washers. Allow material to soak into spaces. Brush out any excess material, so as to not retard curing of the topcoat or result in an unaesthetically pleasing surface.

The penetrating sealer shall be applied within 24-hours after completion of the cleaning operations and before flash-rusting occurs. No bare steel surface prepared for penetrating sealer application shall be left uncoated long enough to allow the formation of rust. Cleaned areas upon which rust has formed shall be re-cleaned in accordance with the cleaning

requirement at no additional cost. The presence of rust shall be determined by the Engineer.

The receiving steel surface shall be clean and absolutely dry. The permissible steel surface temperature and the ambient temperature shall be as recommended by the sealer manufacturer. However, in no case, shall the penetrating sealer be applied when the steel surface or the ambient temperatures is below 36°F or above 104°F, or the relative humidity exceeds 99% or a 3.6°F (2°C) temperature-Dew Point temperature spread.

Drying time is temperature, humidity, and film thickness dependent. Use manufacturer's recommended drying schedule to estimate the drying time of the penetrating sealer for application of the other coatings. If the manufacturer's recommendations allow, the use of forced air pressure to dry the surface will be permitted.

#### HRCSA – STRIPING AND TOPCOAT

No application of any stripe/primer shall be allowed until cleaning and preparation of the substrate has been approved by the Engineer. See drawings to determine exact location of structure components to be painted.

The permissible steel surface temperature and the ambient temperature shall be as recommended by the coating manufacturer. However, in no case, shall the coating be applied when the steel surface or the ambient temperatures is below 36°F or above 104°F, or the relative humidity exceeds 99% or a 3.6°F (2°C) temperature-Dew Point temperature spread

The Contractor shall provide paintbrushes, rollers, and spray equipment to conduct the work as specified in this Section.

The Contractor shall also provide specialized equipment as required for the painting of limited access areas and for other difficult-to-clean areas. Specialized equipment may include, but is not limited to:

- Pole guns for spray painting
- Mitts, daubers, or other methods to supplement brush application

Stripe painting will be required on the following surfaces that have been cleaned: edges of plates, angles, lattice, connections (rivets and bolt heads) or other shapes, corners, crevices, back-to-back angles, and built-up edges. The surfaces of existing steel members to which new steel may be connected (faying surfaces) shall also be cleaned and painted as herein described. The stripe coat shall have a band width of at least 4 in. (101.6 mm) to each side of the adjoining edges and is to completely coat the interior of all crevices. All stripe painting should be applied by spray, but immediately afterwards it may be 'brushed in' using a brush. No other method of paint application will be allowed for stripe painting.

Paint for intermediate coat or topcoat may be applied using spray, brush, or roll methods.

Spray painting will be permitted only within a containment that will contain all of the sprayed material, as approved by the Engineer. Complete protection from paint spatter, spillage, overspray, wind-blown paint, or similar releases of paint shall be provided. Covers, tarps, mesh, and similar materials shall be placed around the work area to protect public and private

# BP-51

Project I-5793

Davidson County

property, pedestrian, vehicular, marine, or other traffic, all portions of the bridge, highway appurtenances, waterways, and similar surrounding areas and property, upon, beneath, or adjacent to the structure.

Apply HRCSA as directed by the manufacturer. Wait time between the stripe coats, intermediate coats, and the topcoat shall be as per the manufacturer's recommendations. The following paint schedule shall be used unless special exceptions are submitted and approved according to manufacturer recommendations prior to the start of this work.

Application Location	Description	Film Thickness
SPOT	Liberally apply a stripe coat to crevice corroded and pack rusted bearings and connections, provide extra material to bolts, nuts and any gaps around rivets.	15-18 mils (wet) 10-12 mils (dry)
SPOT	Over exposed metal areas and areas of tightly adhered contaminant free rust or flash rust apply a spot prime with 5 to 7 mils DFT of Topcoat, including areas mentioned in previous SPOT application	7-10 mils (wet) 5-7 mils (dry)

Prior to placing the subsequent coats, the Contractor will ensure that the prior coat is clean of all foreign matter, such as grease, dirt, bird waste, etc., before application of the subsequent coat.

Sealer, stripe, spots, and finish coats shall be applied in sufficient quantity so as to produce the minimum specified Dry Film Thicknesses (DFT). Care should be taken to not over apply the primer/topcoat, especially on flat surfaces. Maximum 25 mils DFT.

Active calcium sulfonate coatings cure slowly, so wet film measurements may be used as criteria for **preliminary** acceptance of the coating. Wet film thickness (WFT) measurements shall be determined as the job progresses and corrections shall be made during paint application.

Dry film thicknesses shall be determined using SSPC-PA2 – using a digital film thickness gage and a shim – after the coating has cured sufficiently to allow accurate measurements. (Note: Depending upon ambient air conditions, it may take more than one week before DFT measurements can be taken.)

Areas failing to meet the specified WFT range shall be over-coated with the same paint to produce at least the total WFT required.

Paint applied containing unauthorized thinners, paint applied to contaminated surfaces, and paint applied contrary to this Specification shall result in the re-cleaning and re-painting of the surface. The work of re-cleaning, re-painting, or over-coating, if required, shall be performed within 10 days following notification by the Engineer and shall be done by the Contractor to the satisfaction of the Engineer, at no additional cost to the Owner.

## INSPECTION

Each layer of application shall be verified by both Quality Control (QC) and Quality Assurance (QA).

### QUALITY CONTROL INSPECTOR

The Contractor shall provide a quality control inspector in accordance with the SSPC QP guidelines to ensure that all processes, pack rust removal, and each coating application are in accordance with the requirements of the contract. The inspector shall have written authority to perform QC duties to include continuous improvement of all QC internal procedures. The presence of the Engineer or inspector at the work site shall in no way lessen the contractor's responsibility for conformity with the contract.

### QUALITY ASSURANCE INSPECTOR

The quality assurance inspector, which may be a Department employee or a designated representative of the Department, shall observe, document, assess, and report that the Contractor is complying with all of the requirements of the contract. Inspectors employed by the Department are authorized to inspect and/ or test all work performed and materials furnished. Such inspection may extend to all or any part of the work and to the preparation, fabrication, or manufacture of the materials to be used. The inspector is not authorized to alter or waive the requirements of the contract. Each stage in preparing the structure to be coated, which includes, but not limited to washing, pack rust removal, sealing, and application paint system, shall be inspected and approved by the Engineer or his authorized representative.

### INSPECTION ACCESS

The Contractor shall furnish all necessary OSHA-approved apparatus such as ladders, scaffolds, and platforms as required for the Engineer or his inspector to have reasonable and safe access to all parts of the work. The contractor shall illuminate the surfaces to be inspected to a minimum of 50-foot candles of light. All access points shall be illuminated to a minimum of 20-foot candles of light.

### INSPECTION INSTRUMENTS

At a minimum, furnish the following calibrated instruments and conduct the following quality control tests:

- Sling Psychrometer - ASTM E337 - bulb type and tables
- Inspection Mirror
- Surface Temperature Thermometer 30°F to 150°F
- Air Thermometer, pocket type, 30°F to 100°F
- Illuminated Magnifier
- Hypodermic Needle Pressure Gauge



# BP-53

Project I-5793

Davidson County

- Surface Condition Standards - SSPC VIS 1-3 and 4
- Wet Film Thickness Gage - ASTM D4414
- Dry Film Thickness Gage - SSPC-PA2 Modified
- Calibration Standards (NIST Traceable)
- Surface Contamination Analysis Kit or (Chloride, Nitrate, and Sulfate Level Test Kit) SSPC Technology Guide 15

## QUALITY CONTROL

Maintain a daily quality control record in accordance with Article 442-12(D) of the *2018 Standard Specifications* and make such records available at the job site for review by the inspector and submit to the Engineer as directed. In addition to the information required on M&T-610, submit all Dry Film Thickness (DFT) or Wet Film Thickness (WFT) readings on a form equivalent to M&T-611.

Film thickness shall be measured at no less than six random spots per bearing (each of four bearing plate edges and two readings on top of the sole plate). Also, film thickness shall be measured at no less than six random spots per span on diaphragms/"K" frames.

Each spot is an average of three to five individual gage readings as defined in SSPC PA-2. No spot average shall be less than 80% of minimum film thickness for each layer applied; this does not apply to stripe coat application. These non-conforming areas shall be corrected by the Contractor prior to applying successive coats.

Areas failing to meet the specified film thickness range shall be over-coated with the same paint to produce at least the total film thickness required.

## REPAIR OF DAMAGED COATINGS

All damaged coatings, new or existing, shall be repaired prior to project completion and acceptance in accordance with the above specifications for Re-Coating and Over-coating and as directed by the Engineer, at no additional cost to the Owner.

## COATING MANUFACTURER'S REPRESENTATIVE

Unless waived by the Engineer, the Contractor shall make arrangements for a representative of the coating manufacturer to be present on-site as work begins, at a minimum, and as necessary as work progresses, to work together with the Contractor and representatives of the owner and to provide comments and guidance, so that the cleaning, application, and inspection procedures are done properly.

## MEASUREMENT AND PAYMENT

*Painting Containment for Bridge No. \_\_\_\_* will be paid for at the contract lump sum price which price will be full compensation for all collection, handling, storage, air monitoring, and disposal of debris and wash water, all personal protective equipment, and all personal

# BP-54

Project I-5793

Davidson County

hygiene requirements, and all equipment, material and labor necessary to fully contain the paint and water; daily collection of debris into specified containers; and any measures necessary to ensure conformance to all safety and environments regulations as directed by the Engineer.

*Pollution Control* will be paid at the contract lump sum price which will be full compensation for all collection, handling, storage, air monitoring, and disposal of debris and wash water, all personal protective equipment, and all personal hygiene requirements, and all equipment, material and labor necessary for the daily collection of the blast debris into specified containers; and any measures necessary to ensure conformance to all safety and environmental regulations as directed by the Engineer.

*Cleaning and Painting Existing Bearings with HRCSA Bridge No. \_\_\_\_* will be paid for at the contract lump sum price which will be full compensation for all labor, materials and equipment necessary to complete the work. All work shall be done in a manner satisfactory to the Engineer.

Payment will be made under:

<b>Pay Item</b>	<b>Pay Unit</b>
Painting Containment for Bridge No. ____	Lump Sum
Pollution Control	Lump Sum
Cleaning and Painting Existing Bearings with HRCSA Bridge No. ____	Each

## **BRIDGE JOINT DEMOLITION**

**(SPECIAL)**

### **DESCRIPTION**

This provision addresses the removal of existing joint material and adjacent concrete to facilitate the installation of new bridge joints at the locations noted in the contract plans.

### **EQUIPMENT**

Use the following surface preparation equipment:

- Sawing equipment capable of sawing concrete to a specified depth.
- Power driven hand tools for removal of concrete are required that meet the following requirements:

Pneumatic hammers weighing a nominal 15 lbs (7 kg) or less.

Pneumatic hammer chisel-type bits that do not exceed the diameter of the shaft in width.

- Hand tools such as hammers and chisels for removal of final particles of concrete.

# BP-55

Project I-5793

Davidson County

## REMOVAL AND PREPARATION

Prior to any construction, take the necessary precautions to ensure debris from joint construction is not allowed to fall below the bridge deck.

Remove existing joint material by methods approved by the Engineer. Provide a 1" deep saw cut around the perimeter of areas noted for bridge deck removal.

Remove by chipping with hand tools concrete adjacent to the joint to the limits shown on the contract plans. Use a small chipping hammer (15 lb. class) to prepare the edges of the repair area to limit micro fractures. In addition, all loose and unsound concrete shall be removed.

In overhangs, removing concrete areas greater than 0.60 ft<sup>2</sup>/ft length of bridge will require overhang support. Submit the overhang support method to the Engineer for approval.

Care shall be taken not to cut, stretch, or damage any exposed reinforcing steel. Dispose of the removed concrete.

If the condition of the concrete is such that deep spalls or sheer faces result, notify the Engineer for the proper course of action.

Clean, repair or replace rusted or loose reinforcing steel. Thoroughly clean the newly exposed surface to be free of all grease, oil, curing compounds, acids, dirt, or loose debris.

## MEASUREMENT AND PAYMENT

*Bridge Joint Demolition* will be measured and paid for at the contract unit price bid per square foot and will be full compensation for removal, containment and disposal of existing joint material and concrete and shall include the cost of labor, tools, equipment and incidentals necessary to complete the work.

<b>Pay Item</b>	<b>Pay Unit</b>
Bridge Joint Demolition	Square Feet

## CONCRETE DECK REPAIR FOR EPOXY OVERLAY

(12-12-13)

### 1.0 GENERAL

This provision addresses concrete deck repairs prior to placing an epoxy overlay. Work shall begin within 60 days of notification. After surface preparation, the Engineer sounds the deck using a chain drag or other acceptable means and marks areas to be repaired.

### 2.0 MATERIALS

Concrete deck repair material shall be epoxy based material with a minimum modulus of elasticity of 2500 ksi. The repair material must be on the NCDOT Approved Product List

(APL) and recommended by the manufacturer for use with an epoxy overlay system. Materials containing cement mortar are acceptable; however, a 28 day curing period will be required before placing the epoxy overlay. The curing period may be adjusted if approved by the epoxy overlay manufacturer and the Engineer. Submit the proposed repair material and schedule of repairs to the Engineer for approval prior to beginning the work.

### 3.0 CLASS II SURFACE PREPARATION (PARTIAL DEPTH)

Saw cut a perimeter surrounding the repair to a depth not less than 1 inch and remove all loose, unsound and contaminated material by chipping with hand tools to an average depth of approximately one-half the deck thickness, but no less than 3/4 inch below the top mat of steel. Clean, repair or replace rusted or loose reinforcing steel. Care shall be taken not to cut, stretch, or damage any exposed reinforcing steel. Thoroughly clean the newly exposed surface. Use a bonding agent in accordance with the manufacturer's recommendations.

### 4.0 APPLICATION

Refill areas where concrete is removed with repair material up to the finished deck surface and cure in accordance with the material manufacturer's recommendations. Provide a raked finish.

### 5.0 MEASUREMENT & PAYMENT

*Concrete Deck Repair for Epoxy Overlay* will be measured and paid for at the contract unit price per square feet for the appropriate areas repaired. The price shall include materials, labor, equipment, tools and any incidentals necessary to complete the work.

Payment will be made under:

<b>Pay Item</b>	<b>Pay Unit</b>
Concrete Deck Repair for Epoxy Overlay	Square Feet

## EPOXY OVERLAY SYSTEM

(SPECIAL)

### 1.0 GENERAL

This work shall consist of furnishing and applying an epoxy overlay system over the concrete bridge deck in accordance with the contract documents. Epoxy overlay system consists of a minimum of two (2) layers of hybrid polymer resins, with a special blend of extremely hard aggregate designed to provide a 3/8 inch thick overlay for the purpose of crack treatment, complete waterproofing, and providing a non-skid surface. The overlay system shall be

formulated and applied to withstand continuous heavy traffic, extreme changes in weather conditions, and deformations due to structure loading and temperature changes.

## 2.0 PERFORMANCE GUARANTEE

The Contractor shall provide a warranty bond to the Department, guaranteeing the wearing surface for a period of 36 months against the following defects: delamination of the epoxy overlay from the deck surface, and skid resistance less than 40 as measured by AASHTO T242. The performance bond will be invoked if 25 square feet of the deck surface meets the defect criteria prior to the end of the warranty. The guarantee period will start on the date of Department final acceptance of the project. At the end of the guarantee period, the warranty bond will be invoked if any part of deck surface meets the defect criteria, regardless of quantity.

The Contractor shall replace defective materials and workmanship at no cost to the Department. The Contractor will not be responsible for damage due to normal wear and tear, negligence on the part of the Department, or use in excess of the design.

The warranty bond amount shall be the bid quantity of epoxy overlay multiplied by the statewide average unit bid price for the epoxy overlay. The guarantee period of 36 months and bond value shall be specified in the warranty bond provided to the Department prior to final acceptance of the project.

## 3.0 MATERIALS

This two-part epoxy polymer overlay system shall be on the NCDOT Approved Products List (APL) and be free of any fillers or volatile solvents and shall be formulated to provide a simple volumetric mixing ratio of two components such as one to one or two to one by volume. The epoxy overlay system shall be formulated to provide flexibility in the system without any sacrifice of the hardness, chemical resistance, or strength of the system. Use of external/conventional flexibilizers will not be accepted. Flexibility shall be by interaction of elastomers, which chemically link during the process of curing so the flexibility of the molecule is least affected during the low temperature conditions that are confronted in actual use.

### Epoxy

When the two-component system is mixed at the appropriate ratio, the cured resin shall conform to the following requirements:

<b>EPOXY PROPERTIES</b>		
<b>Property</b>	<b>Requirement</b>	<b>Test Method</b>
Viscosity-Poises at 77°F ± 2°F	7-25	ASTM D2393 (Spindle No.3 at 20 rpm)
Pot Life	15-45 minutes @ 75° F	ASTM C881
Min. Tensile Strength at 7 days	2000 psi	ASTM D638
Tensile Elongation at 7 days	30-70%	ASTM D638

# BP-58

Project I-5793

Davidson County

Min. Compressive Strength @ 3 hrs.	1,000 psi	ASTM C109
Min. Compressive Strength @ 24 hrs.	5000 psi	ASTM C109
Min. adhesion strength @ 24 hrs.	250 psi @ 75° F	ASTM C1583
Max. Water Absorption	1%	ASTM D570

## Aggregate

Aggregate used for all layers shall be non-friable, non-polishing, clean, and free from surface moisture. The aggregate shall be flint rock, 100% fractured, thoroughly washed and kiln dried to a maximum moisture content of 0.2% by weight, measured in accordance with ASTM C566. The fracture requirements shall be at least one mechanically fractured face and will apply to materials retained on a U.S. No. 10 sieve. Aggregate shall conform to the following requirements:

AGGREGATE PROPERTIES		
Property	Value	Test Method
Moisture Content, max.	0.2% by weight	AASHTO T255
Mohs Hardness, min.	7	
Soundness Loss, 5 cycles in Sodium Sulfate, max.	5.4%	AASHTO T104
Micro-Deval, max.	10%	AASHTO TP58

AGGREGATE GRADATION	
Sieve	Percent Passing
No. 4	100
No. 8	30-75
No. 16	Max. 5
No. 30	Max. 1

## 4.0 SURFACE PREPARATION

Remove all existing overlays if applicable, and all loose, disintegrated, unsound or contaminated concrete from the bridge deck. Prepare the bridge deck prior to applying the overlay system, in accordance with the manufacturer's recommendations, the special provision *Concrete Deck Repair for Epoxy Overlay*, and this provision.

Prior to overlay placement and upon completion of the deck repairs, clean the entire deck surface by steel shot blasting and other means to remove asphaltic material, oils, dirt, rubber, curing compounds, pavement markings, paint carbonation, laitance, weak surface mortar and other materials that may interfere with the bonding or curing of the overlay. Do not begin shotblasting until all grinding or milling operations are completed. Use sandblasting equipment on areas that cannot be reached by the shotblasting operation. If expansion joints are not being replaced or have been replaced prior to shotblasting they shall be protected from damage from the shotblasting operation. Pavement markings shall be considered clean when the concrete has

exposed aggregate showing through the paint stripe. Deck drains and areas of curb or railing above the proposed surface shall be protected from the shotblasting operation. Mortar that is soundly bonded to the coarse aggregate shall have open pores to be considered adequate for bond. Provide a self-propelled vacuum capable of picking up dust and other loose material from the shotblasting operation. Provide air compressors equipped with oil/water separator capable of drying all moisture from the bridge deck. Care shall be taken and methods used to fully capture and collect the excess material.

Prior to overlay placement and upon completion of surface preparation, perform bond testing of the epoxy overlay material in accordance with ASTM C1583 on two pre-selected 1.5' x 3' test patches. Test locations will be determined by the Engineer. The tensile strength shall be at least 250 psi and the depth of failure into the concrete deck for 50% of the test patch area shall be ¼" or greater. Install test sections with the same materials, equipment, personnel, timing, and sequence of operations and curing time that will be used for the installation of the overlay. Test locations shall be repaired with approved repair materials.

If the cleaning method, materials, and installation procedure do not produce acceptable test results, the contractor must remove failed test patches, make the necessary adjustments, and retest all patches at no additional cost to the Department until satisfactory test results are obtained.

Epoxy based overlays shall not be placed on hydraulic cement concrete that is less than 28 days old. Patching and cleaning operations shall be inspected and approved prior to placing each layer of the overlay. Any contamination of the deck or intermediate courses, after initial cleaning, shall be removed.

The deck shall be completely dry at the time of application of the epoxy concrete overlay. Deck drains shall be closed off during application of epoxy overlay.

## **5.0 EQUIPMENT**

For mechanical applications, equipment shall consist of no less than an epoxy distribution system, aggregate spreader, application squeegee, and vacuum truck. The distribution system shall accurately measure and mix the epoxy resin and hardening agent, and shall uniformly and accurately apply the epoxy materials at the specified rate to the bridge deck, in such a manner as to cover 100% of the work area. The aggregate spreader shall be propelled in such a manner as to uniformly and accurately apply the aggregate to cover 100% of the epoxy material. Aggregate shall be sprinkled or dropped vertically in a manner such that the level of the epoxy mixture is not disturbed. The vacuum truck shall be self-propelled.

For hand applications, equipment shall consist of calibrated containers, a "jiffy" type paddle mixer or other paddle designed specifically for epoxy mixing, squeegees, rollers and brooms, which are suitable for mixing the epoxy and applying the epoxy and aggregate. Paddle shall remain submerged when mixing to avoid entraining air. Equipment shall uniformly and accurately apply the epoxy materials at the specified rate to the bridge deck, in such a manner

# BP-60

as to cover 100% of the work area. The aggregate shall be applied in such a manner as to uniformly and accurately cover 100% of the epoxy material. Aggregate shall be sprinkled or dropped vertically in a manner such that the level of the epoxy mixture is not disturbed

A source of lighting shall be provided by Contractor, when work is to be performed during times of diminished light.

## 6.0 APPLICATION

Handling and mixing of the epoxy resin and hardening agent shall be performed in a safe manner to achieve the desired result in accordance with the manufacturer's recommendations as approved and as directed by the Engineer. Epoxy overlay materials shall not be placed when weather or surface conditions are such that the material cannot be properly handled, placed, spread, and cured within the specified requirements of traffic control.

The application rates of the liquid and stone in the two layers shall be as recommended by the manufacturer, but not less than the following rate of application.

TABLE 4		
APPLICATION RATES		
Course	Min. Epoxy Rate (Gal./100 SF)	Min. Aggregate Rate (Lbs./Sq.Yd)
1	2.5	10
2	5	14

The final overlay thickness shall be a minimum of 3/8". Once the epoxy mixture has been prepared, immediately and uniformly apply it to the surface of the bridge deck. There shall be no longitudinal joints of the epoxy overlay in the wheel path. The temperature of the bridge deck surface and all epoxy and aggregate components shall be 60°F or above at the time of application. Epoxy shall not be applied if the air temperature is expected to drop below 55°F within 8 hours after application or if air temperatures would cause the gel time to be less than 10 minutes. Consult with the manufacturer when placing overlay at temperatures above 90°F. The dry aggregate shall be applied in such a manner as to completely cover the epoxy mixture, so that no wet spots appear and before epoxy begins to gel. First course applications that do not receive enough aggregate prior to gel shall be removed and replaced. A second course insufficiently covered with aggregate may be left in place, but will require additional applications before opening to traffic. After each course is fully cured, all loose aggregate shall be removed by vacuuming or brooming. Traffic shall not be allowed on the first course of the overlay. Traffic and equipment shall not be permitted on the overlay surface during the curing period. The minimum curing periods shall be as follows:

**Course: Average temperature of deck, epoxy, and aggregate components in °F**

	60-64	65-69	70-74	75-79	80-84	85+
Course 1	4 hrs.	3 hrs.	2.5 hrs.	2 hrs.	1.5 hrs.	1 hr.
Course 2	6.5 hrs.*	5 hrs.	4 hrs.	3 hrs.	3 hrs.	3 hrs.

\*Course 2 shall be cured for 8 hrs. if the air temperature drops below 60°F during the curing period.



# BP-61

Project I-5793

Davidson County

The Contractor shall plan and execute the work to provide the curing periods as specified herein, or manufacturer proposed curing periods may be submitted to the Engineer for review and approval.

Do not apply epoxy overlay courses over modular joints, metal expansion joints, or foam joint seals. A bond breaker shall be placed on all expansion joints.

In the event the Contractor's operation damages the epoxy overlay, the Contractor shall remove the damaged areas by saw-cutting in rectangular sections to the top of the concrete deck surface and replacing the various courses in accordance with this Specification at no additional cost to the Department.

Prior to acceptance, perform bond testing for each span or 300 square yards, whichever is smaller, in accordance with ASTM C1583 on 1.5' x 3' test patches. Test locations will be determined by the Engineer. The tensile strength shall be at least 250 psi and the depth of failure into the concrete deck for 50% of the test patch area shall be ¼" or greater. Unacceptable test results will require removal and replacement of overlay as directed by the Engineer at no cost to the Department. Test locations shall be repaired with approved repair materials.

## 7.0 MEASUREMENT & PAYMENT

*Epoxy Overlay System* will be measured and paid for at the contract unit price per square feet. The price shall include surface preparation, furnishing, and placing the overlay system, providing a 36-month warranty bond, and all tools, labor, materials, bond strength testing, and any incidentals necessary to complete the work.

Payment will be made under:

<b>Pay Item</b>	<b>Pay Unit</b>
Epoxy Overlay System	Square Feet

## **ZONE PAINTING OF EXISTING STRUCTURE**

**(SPECIAL)**

### **DESCRIPTION**

This work shall consist of furnishing all labor, equipment, and materials necessary to clean and paint the zones of the existing structure, as indicated on the project plans. Work includes: removal, containment and disposal of the existing paint system; preparation of the surface to be painted and applying the new paint system; a containment enclosure; and any incidentals necessary to complete the project as specified and shown on the plans.

### **CERTIFICATION**

Only contractors who are currently SSPC QP 1 certified, and have successfully completed field painting on similar structures within 18 months prior to this bid, may perform this work.

Successfully completed projects shall have all lead abatement work completed in accordance with the contract and be free of citation from safety or environmental agencies. Lead abatement work shall include, but not be limited to: abrasive blasting; waste handling, storage and disposal; worker safety during lead abatement activities (fall protection, PPE, etc.); and containment. This requirement is in addition to the Contractor pre-qualification requirements covered by Article 102-2 of the *2018 Standard Specifications*.

**TWELVE-MONTH OBSERVATION PERIOD**

The Contractor maintains responsibility for the coating system for a 12-month observation period beginning upon the satisfactory completion of all the work required in the plans or as directed by the Engineer. The Contractor shall guarantee the coating system under the payment and performance bond (refer to Article 109-10 of the *2018 Standard Specifications*). For successful completion of the observation period, the coating system shall meet the following requirements after 12 months service:

- (A) No visible rust, contamination or application defect is observed in any coated area.
- (B) Painted surfaces have a uniform color and gloss.
- (C) Painted surfaces have an adhesion that meets an ASTM D3359, 3A rating.

Final acceptance is made only after the paint system meets the above requirements.

**SUBMITTALS**

Submit all of the following to the Engineer for review and approval before scheduling the pre-construction meeting. Allow at least 2 weeks for the review process.

- (A) Work schedule which shall be kept up to date, with a copy of the revised schedule being provided to the Engineer in a timely manner,
- (B) Containment Drawings in accordance with SSPC Guide 6, Class 2A sealed by a Professional Engineer licensed by the State of North Carolina,
- (C) Bridge wash water sampling and disposal plan,
- (D) Subcontractor identification,
- (E) Lighting plan for night work in accordance with Section 1413 of the *2018 Standard Specifications*,
- (F) Traffic control plan with NCDOT certified supervisors, flaggers and traffic control devices,
- (G) Health and Safety Plan addressing at least the required topics as specified by the SSPC QP 1 program which includes, but is not limited to: hazardous materials, personal protective equipment, hand and power tools, ladders, toxic and hazardous substances, emergency procedures, and local hospital and treatment facilities with directions and phone numbers, disciplinary criteria for workers who violate the plan and accident investigation,
- (H) Provide the Engineer with Competent Person qualifications and summary of work experience.
- (I) Environmental Compliance Plan

- (J) Quality Control Plan (Project Specific) with quality control qualifications and summary of work experience.
- (K) Bridge and Public Protection Plan (Overspray, Utilities, etc. - Project/Task Specific)
- (L) Abrasive Blast Media
  - (1) Product Data Sheet
  - (2) Blast Media Test Reports in accordance with Article 1080-12 of the *2018 Standard Specification*.
- (M) Coating Material
  - (1) NCDOT HICAMS Test Reports (testing performed by NCDOT Materials and Tests Unit),
  - (2) Product Data Sheets,
  - (3) Material Safety Data Sheets,
  - (4) Product Specific Repair Procedures, and
  - (5) Acceptance letters from paint manufacturers for work practices that conflict with Project Special Provisions and/or paint manufactures' product data sheets.

**PRE-CONSTRUCTION MEETING**

Submittals shall be reviewed and approved by the Engineer prior to scheduling the pre-construction meeting. Allow no less than 2 weeks for a review process. When requesting a pre-construction meeting, contact the Engineer at least 7 working days in advance of the desired pre-construction date. The contractor's project supervisor, Competent person, quality control personnel and certified traffic control supervisor shall be in attendance at the pre-construction meeting in order for the Contractor and NCDOT team to establish responsibilities for various personnel during project duration and to establish realistic timeframes for problem escalation.

**CONTAINMENT PLAN**

The containment plan shall meet Class 2A containment in accordance with SSPC Guide 6. Enclosure drawings and loads supported by the structure shall be prepared, signed, and sealed by a Professional Engineer licensed by the State of North Carolina. Describe what physical containment will be provided during painting application to protect the public and areas not to be painted. Protect non-metallic parts of bearings from blasting and painting (i.e.: Pot Bearings, Elastomeric Pads, and Disc Bearings).

**WASH WATER SAMPLING AND DISPOSAL PLAN**

No work may begin until the Contractor furnishes the Engineer with a containment plan for surface preparation and coating operations and the Engineer reviews and approves in writing said plan. All wash water shall be collected and sampled prior to disposal. Representative sampling and testing methodology shall conform to 15A NCAC 02B.0103, "Analytical Procedures." Wash water shall be tested for pollutants listed in 15A NCAC 02B.0211(3), 15A NCAC 02T.0505(b)(1) and 15A NCAC 2T.0905(h). Depending on the test results, wash water disposal methods shall be described in the disposal plan. Wash water shall be disposed of in accordance with all current Federal and State regulations. See link for NCDOT

# BP-64

Project I-5793

Davidson County

Guidelines for Managing Bridge Wash Water:  
<http://www.ncdot.gov/projects/ncbridges/#stats>.

## WASTE HANDLING OF PAINT AND ABRASIVES

Comply with all Federal, State, and local regulations. Failure to comply with the regulations could result in fines and loss of qualified status with NCDOT.

Comply with the Resource Conservation and Recovery Act (RCRA - 40 CFR 261 - 265) and the Occupational Safety and Health Act (OSHA - 29 CFR 1910 - 1926) regulations for employee training, and for the handling, storage, labeling, recordkeeping, reporting, inspections and disposal of all hazardous waste generated during paint removal. All waste, hazardous or non-hazardous, requires numbered shipping manifests.

Comply with the NCDENR Hazardous Waste Compliance Manual for Generators of Hazardous Waste. Record quantities of waste by weight and dates of waste generation. Until test results are received, store all waste, and label as "NCDOT Bridge Paint Removal Waste - Pending Analysis" and include the date generated and contact information for the Division HazMat Manager or Project Engineer. Store waste containers in an enclosed, sealed, and secured storage container protected from traffic from all directions. Obtain approval for the protection plan for these containers from the Engineer. If adequate protection cannot be obtained by use of existing guardrail, provide the necessary supplies and equipment to maintain adequate protection. Once test results are received and characterized, label waste as either "Hazardous Waste - Pending Disposal" or "Paint Waste - Pending Disposal."

The North Carolina Department of Environment and Natural Resources (NCDENR) adopted RCRA as the North Carolina Hazardous Waste Management Rules and is responsible for enforcement. The "Hazardous Waste Compliance Manual for Generators of Hazardous Waste" is published by the Compliance Branch of the Division of Waste Management of NCDENR and can be found at <http://portal.ncdenr.org/web/wm/hw/rules>.

If waste is considered hazardous, the following applies:

Use a company from the below list of approved waste management companies. Immediately after award of the contract, arrange for waste containers, sampling, testing, transportation, and disposal of all waste. No work shall begin until the Contractor furnishes the Engineer with a written waste disposal plan. Any alternative method for handling waste shall be pre-approved by the Engineer.

Southern Logistics, Inc. – 312 Orville Wright Dr., Greensboro, NC 27409  
(Ph. 336-662-0292)

A&D Environmental – PO Box 484, High Point, NC 27261  
(Ph. 336-434-7750)

Poseidon Environmental Services, Inc. – 837 Boardman-Canfield Rd #209, Youngstown, OH  
(Ph. 330-726-1560)

Clean Harbors Reidsville, LLC – 208 Watlington Industrial Drive, Reidsville, NC 27320  
(Ph. 336-342-6106)

# BP-65

Project I-5793

Davidson County

Test all removed paint and spent abrasive media for lead following the SW-846 TCLP Method 1311 Extraction, as required in 40 CFR 261, Appendix 11, to determine whether it shall be disposed of as hazardous waste. Furnish the Engineer certified test reports showing TCLP results and Iron analysis of the paint chips stored on site, with disposal being in accordance with “Flowchart on Lead Waste Identification and Disposal” at:

[http://portal.ncdenr.org/c/document\\_library/get\\_file?p\\_l\\_id=38491&folderId=328599&name=DLFE-9855.pdf](http://portal.ncdenr.org/c/document_library/get_file?p_l_id=38491&folderId=328599&name=DLFE-9855.pdf).

All sampling shall be done in presence of the Engineer’s representative.

The Competent Person shall obtain composite samples from each barrel of the wash water and waste generated by collecting two or more portions taken at regularly spaced intervals during accumulation. Composite the portions into one sample for testing purposes. Acquire samples after 10% or before 90% of the barrel has accumulated. The intent is to provide samples that are representative of widely separated portions, but not the beginning and end of wash water or waste accumulation.

Perform sampling by passing a receptacle completely through the discharge stream or by completely diverting the discharge into a sample container. If discharge of the wash water or waste is too rapid to divert the complete discharge stream, discharge into a container or transportation unit sufficiently large to accommodate the flow and then accomplish the sampling in the same manner as described above.

Once the waste has been collected, and the quantities determined, prepare the appropriate shipping documents and manifests and present them to the Engineer. The Engineer will verify the type and quantity of waste and obtain a Provisional EPA ID number from the:

NC Hazardous Waste Section  
North Carolina Department of Environment & Natural Resources  
1646 Mail Service Center  
Raleigh, NC 27699  
Phone (919) 508-8400, Fax (919) 715-4061

At the time of shipping, the Engineer will sign, date, and add the ID number in the appropriate section on the manifest. The maximum on-site storage time for collected waste shall be 90 days. All waste whether hazardous or non-hazardous will require numbered shipping manifests. The cost for waste disposal (including lab and Provisional EPA ID number) is included in the bid price for this contract. Note NC Hazardous Waste Management Rules (15A NCAC 13A) for more information. Provisional EPA ID numbers may be obtained at this link:

<http://portal.ncdenr.org/web/wm/provisional-hw-notification-page>.

# BP-66

Project I-5793

Davidson County

Testing labs shall be certified in accordance with North Carolina State Laboratory Public Health Environmental Sciences. List of certified laboratories may be obtained at this link:

<http://slphreporting.ncpublichealth.com/EnvironmentalSciences/Certification/CertifiedLaboratory.asp>.

All test results shall be documented on the lab analysis as follows:

3. For leachable lead:
  - a. Soils/Solid/Liquid- EPA 1311/200.7/6010

Area sampling will be performed for the first 2 days at each bridge location. The area sample will be located within five feet of the containment and where the highest probability of leakage will occur (access door, etc.). Results from the area sampling will be given to the Engineer within 72 hours of sampling (excluding weekends). If the results of the samples exceed  $20 \mu\text{g}/\text{m}^3$  corrective measures shall be taken and monitoring shall be continued until two consecutive sample results are less than  $20 \mu\text{g}/\text{m}^3$ .

TWA may suspend the work if there are visible emissions outside the containment enclosure or pump monitoring results exceeding the level of  $30 \mu\text{g}/\text{m}^3$ .

Where schools, housing and/or buildings are within 500 feet of the containment, the Contractor shall perform initial TSP-Lead monitoring for the first 10 days of the project during abrasive blasting, vacuuming and containment removal. Additional monitoring will be required during abrasive blasting 2 days per month thereafter. Results of the TSP monitoring at any location shall not exceed  $1.5 \mu\text{g}/\text{m}^3$ .

## **EQUIPMENT MOBILIZATION**

The equipment used in any travel lanes and paved shoulder shall be mobile equipment on wheels that has the ability to move on/off the roadway in less than 30 minutes. All work conducted in travel lanes shall be from truck or trailer supported platforms and all equipment shall be self-propelled or attached to a tow vehicle at all times.

## **QUALITY CONTROL INSPECTOR**

Provide a quality control inspector in accordance with the SSPC QP guidelines to ensure that all processes, preparation, blasting and coating application are in accordance with the requirements of the contract. The inspector shall have written authority to perform QC duties to include continuous improvement of all QC internal procedures. The presence of the engineer or inspector at the work site shall in no way lessen the contractor's responsibility for conformity with the contract.

# BP-67

Project I-5793

Davidson County

## **QUALITY ASSURANCE INSPECTOR**

The quality assurance inspector, which may be a Department employee or a designated representative of the Department, shall observe, document, assess, and report that the Contractor is complying with all of the requirements of the contract. Inspectors employed by the Department are authorized to inspect all work performed and materials furnished. Such inspection may extend to all or any part of the work and to the preparation, fabrication, or manufacture of the materials to be used. The inspector is not authorized to alter or waive the requirements of the contract. Each stage in preparing the structure to be coated which includes but not limited to washing, blasting, coating testing and inspection shall be inspected and approved by the Engineer or his authorized representative.

## **SUBLETTING OF CONTRACT**

Only contractors certified to meet SSPC QP 1 and have successfully completed field painting on similar structures within 18 months prior to this bid are qualified for this work. Work is only sublet by approval of the Engineer.

## **LIMITS OF ZONE PAINTING**

Removal of existing paint system, required surface preparation, and application of new painting system shall extend to the limits indicated on the project plans. Additionally, the new paint system shall overcoat the existing paint system and be blended for a dimension of 6" to 12" beyond the limits of the existing paint removal. The existing paint system that remains in the overcoat area shall be properly prepared for required adhesion of the new paint system.

## **PREPARATION OF SURFACES**

Before any other surface preparation is conducted, all surfaces to be painted shall be power washed to remove dust, salts, dirt, and other contaminants. All wash water shall be contained, collected, and tested in accordance with the requirements of NCDOT Managing Bridge Wash Water specification. Obtain approval of the Engineer and allow all cleaned surfaces to dry to the touch and without standing water before beginning surface preparation or painting activities.

Surface preparation is done with materials meeting Article 1080-12 of the *2018 Standard Specifications*. No silica sand or other silica materials are permitted for use. The profile shall be between 1.0 and 3.0 mils when measured on a smooth steel surface. Conduct and document at least 2 tests per beam/girder and 2 tests per span of diaphragms/cross bracing.

Spread tarpaulins over all pavements and surfaces underneath equipment used for abrasive blasting as well as equipment and containers used to collect abrasive media. This requirement will be enforced during activity and inactivity of equipment.

# BP-68

Project I-5793

Davidson County

Before the Contractor departs from the work site at the end of the work day, collect all debris generated during surface preparation and all dust collector hoses, tarps or other appurtenances containing blasting residue in approved containers.

Clean a 3" x 3" area at each structure to demonstrate the specified finish, and the inspector will preserve this area by covering it with tape, plastic or some other suitable means so that it can be retained as the Dry Film Thickness (DFT) gauge adjustment standard. An acceptable alternative is for the Contractor to provide a steel plate with similar properties and geometry as the substrate to be measured.

The contractor and/ or quality assurance representative shall notify the Engineer of any area of corroded steel that has lost more than 50% of its original thickness.

All parts of the bridges not to be painted and the travelling public shall be protected from overspray. Submit a plan to protect all parts of bridge that are not required to be painted and a plan to protect the traveling public and surrounding environment while applying all coats of paint to a structure.

Ensure that chloride levels on the surfaces are  $7 \mu\text{g}/\text{cm}^2$  or lower using an acceptable sample method in accordance with SSPC Guide 15. The frequency of testing shall be 2 tests per span after all surface preparation has been completed and immediately prior to painting. Select test areas representing the greatest amount of corrosion in the span as determined by the Engineers' representative. Additional testing may be required if significant amounts of chloride are detected.

## PAINTING OF STEEL

Paint System 1, as specified in these special provisions and Section 442 of the *2018 Standard Specifications*, is to be used for this work. System 1 is an inorganic zinc primer, two coats acrylic paint, and one stripe coat of acrylic paint over blast-cleaned surfaces in accordance with SSPC-SP-10 (Near White Blast). Perform all mixing operations over an impervious surface with provisions to prevent runoff to grade of any spilled material. The contractor is responsible for reporting quantities of thinner purchased as well the amounts used. No container with thinner shall be left uncovered, when not in use.

Apply 2" stripe coat, by brush or roller only, to all exposed edges of steel including fasteners before applying the finish coat. Locate the edge or corner in the approximate center of the paint stripe.

Painting shall cover the area where existing paint has been removed, and paint shall be blended for a dimension of 6" to 12" onto the existing paint system.

Any area where newly applied paint fails to meet the specifications shall be repaired or replaced by the Contractor. The Engineer approves all repair processes before the repair is made. Repaired areas shall meet the specifications. The Contractor applies an additional finish coat of paint to areas where the tape adhesion test is conducted.



## MATERIALS

Only paint suppliers that have a NCDOT qualified inorganic zinc primer may furnish paints for this project. All paints applied to a structure shall be from the same supplier. Before any paints are applied, the Contractor shall provide the Engineer a manufacturer's certification that each batch of paint meets the requirements of the applicable Section 1080 of the *2018 Standard Specifications*.

Color of the paint shall match that of the existing paint on the structure steel.

The inspector randomly collects a one-pint sample of each paint product used on the project. Additional samples may be collected as needed to verify compliance to the specifications.

Do not expose paint materials to rain, excessive condensation, long periods of direct sunlight, or temperatures above 110°F or below 40°F. In addition, the Contractor shall place a device that records the high, low, and current temperatures inside the storage location. Follow the manufacturer's storage requirements if more restrictive than the above requirements.

## INSPECTION

Surface Preparation for System 1 shall be in accordance with SSPC SP-10. Any area(s) not meeting SSPC SP-10 shall be remediated prior to application of coating. Surface inspection is considered ready for inspection when all blast abrasive, residue and dust is removed from surfaces to be coated.

### (A) Quality Assurance Inspection

The Contractor furnishes all necessary OSHA approved apparatus such as ladders, scaffolds and platforms as required for the inspector to have reasonable and safe access to all parts of the work. The contractor illuminates the surfaces to be inspected to a minimum of 50-foot candles of light. All access points shall be illuminated to a minimum of 20-foot candles of light.

NCDOT reserves the right for ongoing QA (Quality Assurance) inspection to include, but not limited to surface contamination testing, adhesion pull testing, and DFT readings as necessary to assure quality.

Inform the Engineer and the Division Safety Engineer of all scheduled and unannounced inspections from SSPC, OSHA, EPA, and/or others that come on site. Furnish the Engineer a copy of all inspection reports except for reports performed by a third party and or consultant on behalf of the Contractor.

**(B) Inspection Instruments**

At a minimum, furnish the following calibrated instruments and conduct the following quality control tests:

- (1) Sling Psychrometer - ASTM E337 - bulb type
- (2) Surface Temperature Thermometer
- (3) Wind Speed Indicator
- (4) Tape Profile Tester - ASTM D4417 Method C
- (5) Surface Condition Standards - SSPC VIS-1 and VIS-3
- (6) Wet Film Thickness Gage - ASTM D4414
- (7) Dry Film Thickness Gage - SSPC-PA2 Modified
- (8) Pencil Hardness Test - ASTM D3363
- (9) Adhesion Test Kit - ASTM D3359 Method A (Tape Test)
- (10) Adhesion Pull test - ASTM D4541
- (11) Surface Contamination Analysis Kit or (Chloride Level Test Kit)  
SSPC Technology Guide 15

**(C) Quality Control**

Maintain a daily quality control record in accordance with Article 442-12(D) of the *2018 Standard Specifications*, make such records available at the job site for review by the inspector, and submit to the Engineer as directed. In addition to the information required on M&T-610, submit all Dry Film Thickness (DFT) readings on a form equivalent to M&T-611.

Measure DFT at each spot on the attached diagram and at the required number of locations as specified below:

- (3) For span members with a height 36" or less check two (2) random locations along each member in each span.
- (4) For span members with a height 36" or greater check three (3) random locations along each member in each span.

Stiffeners and other attachments to beams and or plate girders shall be measured at no less than two random spots per span. Also, dry film thickness is measured at no less than two random spots per span on diaphragms/"K" frames.

Each spot is an average of three to five individual gauge readings as defined in SSPC PA-2. No spot average shall be less than 80% of minimum DFT for each layer applied; this does not apply to stripe coat application. Spot readings that are nonconforming shall be re-accessed by performing additional spot measurements not to exceed one-foot intervals on both sides of the low areas until acceptable spot averages are obtained. These non-conforming areas shall be corrected by the Contractor prior to applying successive coats.

# BP-71

**Less than 36" in height and/or bottom flanges less than 16" in width.**

**7 Spot Areas**  
**21 Individual DFT Readings**

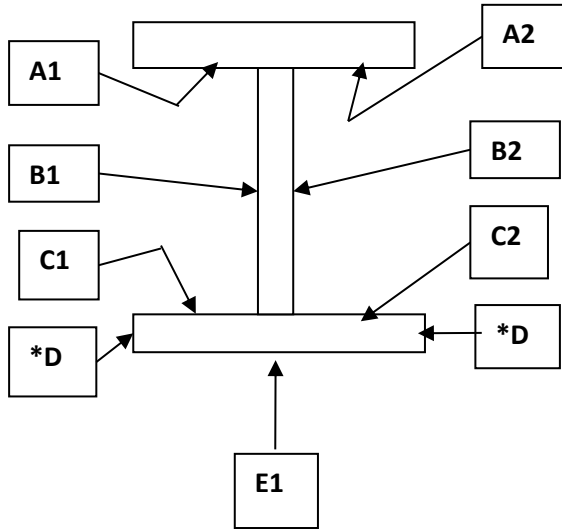

**\*D areas are only included when flange thickness is one inch (1") or greater.**

**36" in height or greater and/or bottom flanges greater than 16" in width.**

**10 Spot Areas**  
**30 Individual DFT Readings**

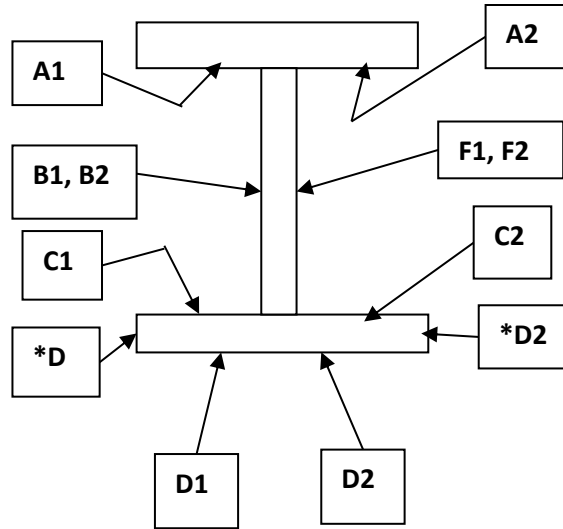

**\*D areas are only included when flange thickness is one inch (1") or greater.**

Two random adhesion tests (1 test=3 dollies) per span are conducted on interior surfaces in accordance with ASTM D4541 (Adhesion Pull Test) after the prime coat has been properly cured in accordance with ASTM D3363 (Pencil Hardness) with no less than 2H, and will be touched up by the Contractor. The required minimum average adhesion is 400 psi.

Cure of the intermediate and stripe coats shall be assessed by using the thumb test in accordance with ASTM D1640 (Curing Formation Test) prior to the application of any successive layers of paint.

One random Cut Tape adhesion test per span is conducted in accordance with ASTM D3359 (X-Cut Tape Test) on interior surface after the finish coat is cured. Repair areas shall be properly tapered and touched up by the Contractor.

**SAFETY AND ENVIRONMENTAL COMPLIANCE PLANS**

Personnel access boundaries are delineated for each work site using signs, tape, cones, or other approved means. Submit copies of safety and environmental compliance plans that comply with SSPC QP 1 Certification requirements.

**HEALTH AND SAFETY RESPONSIBILITIES**

This project may involve toxic metals such as arsenic, lead, cadmium and hexavalent chromium. It is the contractor's responsibility to test for toxic metals and if found, comply with the OSHA regulations, which may include medical testing.

Ensure a "Competent Person" as defined in OSHA 29 CFR 1926.62 - one who is capable of identifying existing and predictable hazards in the surroundings or working conditions which are unsanitary, hazardous, or dangerous to employees, and who has authorization to take prompt corrective measures to eliminate them - is on site during all surface preparation activities and monitors the effectiveness of containment, dust collection systems, and waste sampling. Before any work begins, provide a written summary of the Competent Person's safety training.

Comply with Subarticle 442-14(B) of the *2018 Standard Specifications*.

Comply with Subarticle 442-14(D) of the *2018 Standard Specifications*. Ensure employee blood sampling test results are less than 50 micrograms per deciliter. Remove employees with a blood sampling test of 50 or more micrograms per deciliter from work activities involving any lead exposure.

An employee who has been removed with a blood level of 50 micrograms per deciliter or more shall have two consecutive blood sampling tests spaced one week apart indicating that the employee's blood lead level is at or below 40 micrograms per deciliter before returning to work activities involving any lead exposure.

All OSHA recordable accidents that occur during the project duration are to be reported to the Engineer within twenty-four (24) hours of occurrence. In addition, for accidents that involve civilians or property damage that occurs within the work zone the Division Safety Engineer shall be notified immediately.

Prior to blasting operations, the Contractor shall have an operational OSHA approved hand wash station at each bridge location and a decontamination trailer at each bridge or between bridges unless the work is on the roadway, or the Contractor shall show reason why it is not feasible to do so and provide an alternative site as approved by the Engineer. The Contractor shall assure that all employees whose airborne exposure to lead is above the PEL shall shower at the end of their work shift.

# BP-73

Project I-5793

Davidson County

## STORAGE OF PAINT AND EQUIPMENT

Provide a location for materials, equipment, and waste storage. Spread tarpaulins over all pavements and surfaces underneath equipment used for abrasive recycling and other waste handling equipment or containers. All land and or lease agreements that involve private property shall disclose to the property owner that heavy metals may be present on the Contractor's equipment. Prior to storing the Contractor's equipment on private property, provide a notarized written consent signed by the land owner received by the Engineer at least forty-eight (48) hours before using property. All storage of paint, solvents, and other materials applied to structures shall be stored in accordance with Section 442 of the *2018 Standard Specifications* or the manufacturers' requirements. The more restrictive requirements will apply.

## UTILITIES

Protect all utility lines or mains that may be supported on, under, or adjacent to bridge work sites from damage and paint overspray.

## MEASUREMENT AND PAYMENT

The cost of inspection, surface preparation, and repainting the existing structure is included in the lump sum price bid for *Zone Painting of Existing Structure for Bridge No. \_\_\_*. This price is full compensation for furnishing all inspection equipment, all paint, cleaning abrasives, cleaning solvents and all other materials; preparing and cleaning surfaces to be painted; applying paint in the field; protecting work area, traffic and property; and furnishing blast cleaning equipment, paint spraying equipment, brushes, rollers, any other hand or power tools and any other equipment; and a containment enclosure.

*Pollution Control* will be paid at the contract lump sum price which will be full compensation for all collection, handling, storage, air monitoring, and disposal of debris and wash water, all personal protective equipment, and all personal hygiene requirements, and all equipment, material and labor necessary for the daily collection of the blast debris into specified containers; and any measures necessary to ensure conformance to all safety and environmental regulations as directed by the Engineer.

*Painting Containment for Zone Painting for Bridge No. \_\_\_* will be paid at the lump sum contract price and will be full compensation for the design, materials, installation, maintenance, and removal of the containment system.

Payment will be made under:

<b>Pay Item</b>	<b>Pay Unit</b>
Zone Painting of Existing Structure for Bridge No. ___	Lump Sum
Pollution Control	Lump Sum
Painting Containment for Zone Painting for Bridge No. ___	Lump Sum

**DESCRIPTION OF BRIDGE**

**Bridge #474:** This bridge was built in 1981 and carries I-85 SBL over I-85 NBL. The superstructure consists of 3 simple spans with 8 lines of steel I-beams and plate girders @ 7'-8" spacing with steel cross frames. Span A consists of W36 x 135 steel I-beams throughout. Span B consists of steel plate girders throughout with an 82" web depth, 23" top flange width, and 26" bottom flange width. Span C consists of W36 x 150 steel I-beams for beams 1 through 4, and W36 x 160 steel I-beams for beams 5 through 8. The bridge has an overall length of 318'-0" with a concrete deck and a 58'-10" total deck width. The minimum vertical clearance is 16'-9". The existing paint system is green vinyl over zinc, and the estimated area to be cleaned and painted is **12,419** sq. ft.

**SILICONE JOINT SEALANT****(SPECIAL)****SEALS**

Provide and install a low modulus silicone sealant (non-sag or self-leveling) and backer rod which conforms to the Standard Specifications (Subsections 1023-3 and 1023-4, respectively) and this Special Provision. Use silicone approved for use on joint openings as indicated on project plans and provide a seal with a working range of minimum 50% compression and extension. Silicone joint seal product shall be designated as approved for use on the NCDOT Approved Products List. If non-sag and self-leveling sealants are to be in contact with each other, they shall be from the same manufacturer and shall be compatible for such use.

**PREPARATION OF FORMED OR SAWED JOINT FOR SEAL INSTALLATION**

Joint concrete material or joint concrete header material shall cure a minimum of 24 hours prior to seal installation.

After forming or sawing the joint, the Engineer will thoroughly inspect the joint opening for spalls, popouts, cracks, etc. All necessary repairs will be made by the Contractor prior to blast cleaning and installing the seal.

Clean the joints by sandblasting the joint opening to provide a firm, clean joint surface free of curing compound, loose material, and any foreign matter. Sandblast the joint opening without causing pitting or uneven surfaces. The aggregate in the polyester polymer concrete may be exposed after sandblasting.

After blasting, either brush the surface with clean brushes made of hair, bristle, or fiber, blow the surface with compressed air, or vacuum the surface until all traces of blast products and abrasives are removed from the surface, pockets, and corners. If nozzle blasting is used to clean the joint opening, use compressed air that does not contain detrimental amounts of water or oil.

Examine the blast cleaned surface and remove any traces of oil, grease, or smudge deposited in the cleaning operations.

Install the backer rod and silicone sealant in the blast cleaned opening on the same day the surface is blast cleaned.

**SEAL INSTALLATION**

Install the silicone joint sealant(s) as indicated on the plans, in accordance with the manufacturer’s procedures and recommendations, and as recommended below. Do not install the joint seal if the ambient air or surface temperature is below 45°F. Have a manufacturer’s certified trained factory representative present during the installation of the first seal of the project, to provide guidance for the proper installation of the silicone joint sealant(s).

After a joint has been sealed, remove excess joint sealer on the pavement or bridge deck concrete as soon as possible.

The installed system shall be watertight and will be monitored until final inspection and approval.

Do not place pavement markings on top of pourable joint seals.

**BASIS OF PAYMENT**

*Silicone Joint Sealant* will be measured and paid for at the contract unit price bid per linear foot and will be full compensation for furnishing all material, including backer rod, labor, tools, and equipment necessary for installing these seals in place and accepted.

<b>Pay Item</b>	<b>Pay Unit</b>
Silicone Joint Sealant	Linear Feet

**RAILROAD GENERAL SPECIAL PROVISIONS - CSX TRANSPORTATION, INC.**

When performing work on, over, or adjacent to CSX transportation (“CSXT”) right-of-way or operations, selected contractor (“Contractor”) must abide by the current CSXT Special Provisions and the following additional requirements.

**I. AUTHORITY OF CSXT ENGINEER**

The CSXT Representative shall have final authority in all matters affecting the safe maintenance of CSXT operations and CSXT property, and his or her approval shall be obtained by the Contractor for methods of construction to avoid interference with CSXT operations and CSXT property and all other matters contemplated by the Agreement and these Special Provisions.

**II. INTERFERENCE WITH CSXT OPERATIONS**

- A. Contractor shall arrange and conduct its work so that there will be no interference with CSXT operations, including trail, signal, telephone and telegraphic services, or damage to CSXT’s property, or to poles, wires, and other facilities of tenants on CSXT’s Property or right-of-way. Contractor shall store materials so as to prevent trespassers from causing damage to trains, or CSXT Property. Whenever Work is likely to affect the operations or safety of trains, the method of doing such Work shall first be submitted to the CSXT Representative for approval, but such approval shall not relieve Contractor from liability in connection with such Work.

- B. If conditions arising from or in connection with the Project require that immediate and unusual provisions be made to protect train operation or CSXT's property, Contractor shall make such provision. If the CSXT Representative determines that such provision is insufficient, CSXT may, at the expense of the Contractor, require or provide such provision as may be deemed necessary, or cause the Work to cease immediately.

### III. NOTICE OF STARTING WORK

The Contractor shall not commence any work on CSXT Property or rights-of-way until it has complied with the following conditions:

- A. Notify CSXT in writing of the date that it intends to commence Work on the Project. Such notice must be received by CSXT at least ten business days in advance of the date the Contractor proposes to begin Work on CSXT property. The notice must refer to this Agreement by date. If flagging service is required, such notice shall be submitted at least thirty (30) business days in advance of the date scheduled to commence the Work.
- B. Obtain authorization from the CSXT Representative to begin Work on CSXT property. Such authorization to include an outline of specific conditions with which it must comply.
- C. Obtain from CSXT the names, addresses, and telephone numbers of CSXT's personnel who must receive notice under provisions in the Agreement. Where more than one individual is designated, the area of responsibility of each shall be specified.

### IV. WORK CORRESPONDENCE AND SUBMITTALS

All construction related correspondence will be directed to Arcadis, acting as the Construction Monitoring Representative ("CMR") on behalf of CSXT, with the following contact and address:

Mr. Randy Koonce  
Construction Manager CSXT  
Arcadis  
801 Corporate Center Drive, Suite 300  
Raleigh, NC 27607  
(919) 357-8777

Upon receipt of notification, the CMR will direct the Contractor to the local CSXT construction contact for the project.

All required work plan submittals shall be forwarded to and approved in writing by the Railroad Company prior to proceeding with the work of each applicable phase. Up to thirty (30) days will



be required to review all submittals. Up to an additional thirty (30) days will be required to review any subsequent submissions returned not approved.

#### V. PRECONSTRUCTION MEETING

Prior to any construction activities on or about CSXT, the Contractor shall have a pre-construction meeting with CSXT's designated representative and the CMR to discuss potential on-track safety issues during project construction activities.

#### VI. REQUIRED SUBMITTALS

The Contractor shall submit, including but not limited to, the following construction procedures and documents. The Contractor shall obtain written acceptance of each from CSXT, before proceeding with maintenance work or entering railroad right of way.

- A. Means and Methods – The Contractor shall develop a detailed submission indicating the progression of work with specific times when tasks will be performed during the project. This submission may require a walkthrough at which time CSXT and/or the CMR will be present. Work will not be permitted to commence until the Contractor has provided CSXT with a satisfactory plan that project will be undertaken without scheduling, performance or safety related issues. Provide a listing of the anticipated equipment to be used, the location of all equipment to be used and insure a contingency plan of action is in place should a primary piece of equipment malfunction. All work in the vicinity of CSXT property that has the potential of affecting CSXT train operations must be submitted and approved by CSXT prior to work being performed. This submission will also include a detailed narrative discussing the coordination of project safety issues between NCDOT, Contractor, CSXT and the CMR. The narrative shall address project level coordination and day to day, specific work operations including crane and equipment operations and debris containment.
- B. Containment System – Removed paint and debris may not be deposited on the CSXT right-of-way at any time during cleaning operations. Vacuum type systems for paint removal operations to prevent paint and debris deposits are required in lieu of a containment system over the track(s). The Contractor may submit a containment system for work over CSXT for acceptance by the railroad if the following CSXT horizontal and vertical clearance standards can be maintained. Any temporary containment system shall not encroach horizontally within eighteen feet (18') measured perpendicularly from the centerline of the nearest track. Any containment system must also maintain the existing vertical clearance over all tracks or a minimum of 23'-0" measured from top of high rail to the lowest point of structure in the clearance area which extends 6'-0" to both sides from centerline of track. If the existing vertical clearance is less than 23'-0", no reduction in vertical clearance is permissible. Temporary reductions in vertical and horizontal clearances are not permitted. A construction submittal must be provided and include a written installation and removal procedure and a plan showing the details of the containment

- system. This submission is to include any work platforms with design loads and supporting calculations signed and sealed by a Professional Engineer in the State of North Carolina. The design of the system shall also be in accordance with OSHA and fully comply with all federal, state, and local environment laws, regulations, statutes and ordinances at all times.
- C. Ballast Protection – A ballast protection system may be required at the sole discretion of CSXT depending on the contractor’s proposed methods to perform the work. The system shall use filter fabric and indicate the anchorage system. The ballast protection is to extend a minimum of 25’ beyond the proposed limit of work or greater as determined by CSXT and be continuously maintained to prevent all contaminants from entering the ballast section of all tracks for the entire duration of the project.
- D. Construction Schedule – Within 30 days of the pre-construction meeting, Contractor shall submit a detailed construction schedule for the duration of the project clearly indicating the time periods while working on and around CSXT right-of-way. As the work progresses, the schedule shall be updated and resubmitted as necessary to reflect changes in work sequence, duration and method, etc.
- E. Insurance – Submit all necessary insurance information in accordance with the current CSXT Insurance Requirements for approval. The complete original policies should be submitted to:

[insurancedocuments@csx.com](mailto:insurancedocuments@csx.com)

- with a copy to the CMR. The insurance policies will be required to be in place and approved prior to any work commencing on or that could potentially impact CSXT right-of-way.
- F. Emergency Action Plan – Submit an emergency action plan indicating the location of the site, contact numbers, access to the site, instructions for emergency response and location of the nearest hospitals. This plan should cover all items required in the event of an emergency at the site including fire suppression. Coordinate the Emergency Action Plan with the safety related discussion of the Means and Methods submission discussed above. The plan should also include a method to provide this information to each project worker for each day on site.

## VI. WORK FOR THE BENEFIT OF THE CONTRACTOR

- A. No temporary or permanent changes to wire lines or other facilities (other than third party fiber optic cable transmission systems) on CSXT property that are considered necessary to the Work are anticipated or shown on the Plans. If any such changes are, or become, necessary in the opinion of CSXT or NCDOT, such changes will be covered by appropriate revisions to the Plans and by preparation of a force account estimate. Such force account estimate may be initiated by either CSXT or NCDOT, but must be approved by both CSXT and NCDOT. The Contractor shall be

responsible for arranging for the relocation of the third party fiber optic cable transmission systems, at no cost or expense to CSXT.

- B. Should the Contractor desire any changes in addition to the above, then it shall make separate arrangements with CSXT for such changes to be accomplished at the Contractor's expense.

#### VII. HAUL ACROSS RAILROAD

- A. If Contractor desires access across CSXT property or tracks at other than an existing and open public road crossing in or incident to construction of the Project, the Agency or Contractor must first obtain the permission of CSXT and shall execute a license agreement or right of entry satisfactory to CSXT, wherein Agency or Contractor agrees to bear all costs and liabilities related to such access.
- B. NCDOT and Contractor shall not cross CSXT's property and tracks with vehicles or equipment of any kind or character, except at such crossing or crossings as may be permitted pursuant to this section.
- C. Contractor access will be limited to the immediate project area only. The CSXT right-of-way may not be used for contractor access to the project site and no temporary at-grade crossings will be allowed

#### VIII. COOPERATION AND DELAYS

- A. The Contractor shall arrange a schedule with CSXT for accomplishing work by CSXT. In arranging its schedule, Contractor shall ascertain, from CSXT, the lead time required for assembling crews and materials and shall make due allowance therefore.
- B. The Contractor may not charge any costs or submit any claims against CSXT for hindrance or delay caused by railroad traffic; work done by CSXT or other delay incident to or necessary for safe maintenance of railroad traffic; or for any delays due to compliance with these Special Provisions.
- C. The Contractor shall cooperate with others participating on this Project to the end that all work may be carried on to the best advantage.
- D. The Contractor understands and agrees that neither NCDOT nor CSXT assume any responsibility for work performed by others in connection with the Project. The Contractor further understands and agrees that they shall have no claim whatsoever against NCDOT or CSXT for any inconvenience, delay or additional cost incurred by the Contractor on account of operations by others.

#### IX. CSXT EMERGENCY NUMBER

# BP-80

Project I-5793

Davidson County

The CSXT telephone number for emergencies is 800-232-0144. Reference the CSXT Milepost HTD 8.4, when calling.

## X. STORAGE OF MATERIALS AND EQUIPMENT

The CSXT right-of-way must remain clear for railroad use at all times. Contractor shall not store their materials or equipment on CSXT's property, right-of-way, or where they may potentially interfere with CSXT's operations, unless Contractor has received CSXT Representative's prior written permission. Contractor understand and agree that CSXT will not be liable for any damage to such materials and equipment from any cause and that CSXT may move, or require Contractor to move, such material and equipment at Contractor's sole expense. To minimize the possibility of damage to the railroad tracks resulting from the unauthorized use of equipment, all grading or other construction equipment that is left parked near the tracks unattended by watchmen shall be immobilized to the extent feasible so that it cannot be moved by unauthorized persons.

## XI. CONSTRUCTION PROCEDURES

### A. General

1. Work on CSXT property shall be subject to CSXT inspection and approval.
2. Work on CSXT property shall be in accord with CSXT's written outline of specific conditions and with these Special Provisions.
3. Contractor shall observe the terms and rules of the CSXT Safe Way manual, which Agency and Contractor shall be required to obtain from CSXT, and in accord with any other instructions furnished by CSXT or CSXT's Representative.
4. Contractor access will be limited to the immediate project area only. The CSXT right-of-way may not be used for contractor access to the project site.
5. The Contractor will be required to abide by the provisions of the NCDOT/CSXT Railroad Agreement. Periodically, throughout the project duration, the Contractor will be required to meet, discuss and, if necessary, take immediate action at the discretion of CSXT personnel to comply with provisions of that agreement and these specifications.
6. Contractor agrees to fully comply with all federal, state, and local environmental laws, regulations, statutes and ordinances at all times

### B. Blasting

1. Contractor shall obtain CSXT Representative's and Agency Representative's prior written approval for use of explosives on or adjacent to CSXT property. If permission for use of explosives is granted, Contractor must comply with the following:
  - a. Blasting shall be done with light charges under the direct supervision of a responsible officer or employee of Contractor.

- b. Electric detonating fuses shall not be used because of the possibility of premature explosions resulting from operation of two-way train radios.
  - c. No blasting shall be done without the presence of an authorized representative of CSXT. At least thirty (30) days advance notice to CSXT Representative is required to arrange for the presence of an authorized CSXT representative and any flagging that CSXT may require.
  - d. Contractor must have at the Project site adequate equipment, labor and materials, and allow sufficient time, to (i) clean up (at Contractor's expense) debris resulting from the blasting without any delay to trains; and (ii) correct (at Contractor's expense) any track misalignment or other damage to CSXT's property resulting from the blasting, as directed by CSXT Representative, without delay to trains. If Contractor's actions result in delay of any trains, including Amtrak passenger trains, Agency shall bear the entire cost thereof.
  - e. Contractor shall not store explosives on CSXT property.
2. CSXT Representative will:
- a. Determine the approximate location of trains and advise Contractor of the approximate amount of time available for the blasting operation and clean-up.
  - b. Have the authority to order discontinuance of blasting if, in his or her opinion, blasting is too hazardous or is not in accord with these Special Provisions.

C. DOT Number Identification

The Contractor shall paint on the structure the DOT Number assigned to the grade separation. The number assigned to this grade separation is DOT #836547E. This number shall be affixed at a location on each side of the CSXT tracks or property and in a manner such that it can be readily discerned and visible from track level. The font size of the DOT # numbers and letter should be at least four inches (4") tall and shall be black on a light-colored background or white on a dark-colored background of the grade separation component.

## XII. MAINTENANCE OF DITCHES ADJACENT TO CSXT TRACKS

Contractor shall maintain all ditches and drainage structures free of silt or other obstructions that may result from their operations. Contractor shall provide erosion control measures during construction and use methods that accord with applicable state standard specifications for road and bridge construction, including either (1) silt fence; (2) hay or straw barrier; (3) berm or temporary ditches; (4) sediment basin; (5) aggregate checks; and (6) channel lining. All such maintenance and repair of damages due to Contractor's operations shall be performed at Contractor's expense.

No stormwater from the project may discharge onto the CSXT right-of-way at any time during construction.

The Contractor may be required to submit a detailed erosion control plan for review and acceptance by CSXT or the CMR prior to performing any work.

### XIII. FLAGGING / INSPECTION SERVICE

- A. CSXT has sole authority to determine the need for flagging required to protect its operations and property. In general, flagging protection will be required whenever Contractor or their equipment are, or are likely to be, working within fifty (50) feet of live track or other track clearances specified by CSXT, or over tracks.
- B. All equipment operations that could potentially impact CSXT right-of-way must be coordinated with the CSXT Flagman.
- C. NCDOT shall reimburse CSXT directly for all costs of flagging that is required on account of work within CSXT property shown in the Plans, or that is covered by an approved plan revision, supplemental agreement or change order. All bills shall be prepared in accordance with the Federal-Aid Policy Guide 23 CFR 646B.
- D. The Contractor shall give a minimum of thirty (30) days advance notice to CSXT Representative for anticipated need for flagging service. Flagging requests should be made to CSXT Roadmaster, Ben King, at telephone 336-859-3565. No work shall be undertaken until the flag person(s) is/are at the job site. While CSXT cannot guarantee the availability of flagmen at all requested times, every accommodation will be extended to the Contractor when forces are available. If it is necessary for CSXT to advertise a flagging job for bid, it may take up to 90 days to obtain this service and CSXT shall not be liable for the cost of delays attributable to obtaining such service. Termination or cancellation of a flagman requires ten (10) days notice to avoid incurring costs.
- E. CSXT shall have the right to assign an individual to the site of the Project to perform inspection service whenever, in the opinion of CSXT Representative, such inspection may be necessary. NCDOT shall reimburse CSXT for the costs incurred by CSXT for such inspection service. Inspection service shall not relieve the Contractor from liability for its Work.
- F. CSXT shall render invoices for, and NCDOT shall pay for, the actual pay rate of the flag persons and inspectors used, plus standard additives, whether that amount is above or below the rate provided in the Estimate. If the rate of pay that is to be used for inspector or flagging service is changed before the work is started or during the progress of the work, whether by law or agreement between CSXT and its employees, or if the tax rates on labor are changed, bills will be rendered by CSXT and paid by NCDOT using the new rates. The Contractor shall perform their operations that require flagging protection or inspection service in such a manner and sequence that the cost of such will be as economical as possible.

# BP-83

Project I-5793

Davidson County

## XIV. CLEAN-UP

The Contractor, upon completion of the Project, shall remove from CSXT's Property any temporary grade crossings, any temporary erosion control measures used to control drainage, all machinery, equipment, surplus materials, falsework, rubbish, or temporary buildings belonging to NCDOT or Contractor. The Contractor, upon completion of the Project, shall leave CSXT Property in neat condition, satisfactory to CSXT Representative.

## XV. COMPLETION AND ACCEPTANCE OF WORK:

Upon completion of the work, the Contractor shall remove from within the limits of the railroad right of way all machinery, equipment, surplus materials, rubbish or temporary buildings of the Contractor, and leave said rights-of-way in a neat and orderly condition. After the final inspection has been made and work found to be completed in a satisfactory manner acceptable to the Department of Transportation and the Railroad Company, the Department of Transportation will be notified of the Railroad Company's acceptance in writing by the Railroad Engineer within ten (10) days or as soon thereafter as practicable.

At project completion, a complete set of "As Built" plans for the proposed construction shall be submitted to CSXT Bridge Maintenance and Design Group. CSXT will keep these plans on file in Jacksonville for future reference. Please address these plans to:

Mr. E. D. Sparks, II  
Assistant Chief Engineer Structures  
CSX Transportation  
500 Water Street, J350  
Jacksonville, FL 32202

## XVI. FAILURE TO COMPLY

If Contractor violates or fails to comply with any of the requirements of these Special Provisions, (a) CSXT may require Contractor to vacate CSXT Property; and (b) CSXT may withhold monies due Agency and/or Contractor; (c) CSXT may require Agency to withhold monies due Contractor; and (d) CSXT may cure such failure and the Contractor shall reimburse CSXT for the cost of curing such failure.

## XVIII. TRAIN DATA

### **Davidson Co. Bridge Nos. 495 and 496**

2 Trains/day  
1 track  
25 MPH speed  
Freight only

**INSURANCE SPECIAL PROVISIONS FOR  
CSX TRANSPORTATION, INC.**

- A. In addition to any other forms of insurance or bonds required elsewhere in the contract documents, the Prime Contractor will be required to provide coverage conforming to the requirements of the Federal-Aid Policy Guide outlined under 23 CFR 646A for all work to be performed on Railroad right(s)-of-way under the terms of the contract by carrying insurance as listed below.

If any part of the work is sublet, similar insurance and evidence thereof in the same amounts as required of the Prime Contractor, shall be provided by the subcontractor to cover his operations on railroad right-of-way. As an alternative, the Prime Contractor may provide insurance for the subcontractor by means of separate and individual policies.

**1. CONTRACTOR'S COMMERCIAL GENERAL LIABILITY INSURANCE:**

The Contractor shall procure and maintain, at its expense, an original and one certified copy of the policy **to the Department** as evidence of:

- a. Statutory Worker's Compensation and Employers Liability Insurance with available limits of not less than \$1,000,000, which insurance must contain a waiver of subrogation against CSXT and its Affiliates.
- b. Commercial General Liability coverage (inclusive of contractual liability) with available limits of not less than \$5,000,000 in combined single limits for bodily injury and property damage per occurrence, and covering the contractual liabilities assumed under this Agreement.
- c. Commercial Automobile Liability insurance with limits of not less than \$1,000,000 combined single limit for bodily injury and/or property damage per occurrence.
- d. Such other insurance as CSXT may reasonably require.

Upon request, Licensee shall provide CSXT with a copy of Licensee's applicable insurance policies. A policy endorsement naming CSXT as an additional insured and specifying such coverage shall be furnished to CSXT, and the required coverage will be kept in force until all of the licensee's obligations under this Agreement have been fully discharged and fulfilled, or until Licensee shall have been specifically released by a written instrument signed by an authorized officer of CSXT.

The insurance policies shall provide that the insurance carrier must give CSXT notice at least thirty (30) days in advance of cancellation of coverage, of any change in coverage, or of cancellation of the policy. Notwithstanding any provisions of this Section, the liability assumed by Licensee shall not be limited to the required insurance.



# BP-85

Project I-5793

Davidson County

## 2. RAILROAD PROTECTIVE LIABILITY INSURANCE:

The Contractor shall furnish **to the Department** an original and one duplicate of the Railroad Protective Liability Insurance Policy to protect CSXT in connection with operations to be performed on or adjacent to CSXT right of way. The specifications for proper evidence of insurance are as follows:

- a) The Insurer must be financially stable and rated A- or better in A. M. Best Insurance Reports.
- b) The policy must be written using the ISO/RIMA Form of Railroad Protective Insurance - Insurance Services Office (ISO) Form CG 00 35.
- c) CSX Transportation must be the named insured on the Railroad Protective Liability Insurance Policy. The named insured's address should be listed as:

**CSX Transportation, Inc.  
Risk Management (C- 907)  
500 Water Street  
Jacksonville, FL 32202**

- d) Limits of Liability: \$5,000,000 per occurrence, \$10,000,000 annual aggregate required.
- e) Name and Address of Contractor must be shown on the Declarations page.
- f) Name and Address of the Project Sponsor must be shown on the Declarations page.
- g) Terrorism Risk Insurance Act (TRIA) coverage must be included.

Description of operations must appear on the Declarations page and must match the project description, including project or contract identification numbers.

The Description and Designation shall read:

Thomasville, Davidson, North Carolina - Concrete bridge deck rehabilitation by scarification, shot blast cleaning, and placement of an epoxy overlay system; and demolition and reconstruction of bridge deck joints and seals; I-85 NBL and I-85 SBL over CSXT; Florence Division, HD Subdivision; Milepost HTD 8.4; NCDOT Project No. I-5793.

# BP-86

Project I-5793

Davidson County

Authorized endorsements:

**A. Must include:**

- 1) **Pollution Exclusion Amendment - CG 28 31**  
(Not required with CG 00 35 01 96 and newer versions)
- 2) **Delete Common Policy Conditions** – Section E. Premiums

**B. May Include:**

- 1) Broad Form Nuclear Exclusion - IL 00 21
- 2) 30-day Advance Notice of Non-renewal
- 3) Required State Cancellation Endorsement
- 4) Quick Reference or Index - CL/IL 240

**C. May not include:**

- 1) Any Pollution Exclusion Endorsement except CG 28 31
- 2) Any Punitive or Exemplary Damages Exclusion
- 3) Any endorsement not named in A or B
- 4) Any type of deductible policy
- 5) An Endorsement that excludes TRIA coverage
- 6) An Endorsement that limits or excludes Professional Liability coverage
- 7) A Non-Cumulation of Liability or Pyramiding of Limits Endorsement
- 8) A Known Injury Endorsement
- 9) A Sole Agent Endorsement
- 10) A “Common Policy Conditions” Endorsement

- B. Prior to entry on CSXT right-of-way, the **original** Railroad Protective Liability Insurance Policy shall be submitted by the Prime Contractor to the Department at the address below for its review and transmittal to CSXT. In addition, certificates of insurance evidencing the Prime Contractor’s Commercial General Liability Insurance shall be “issued” to CSXT **and** the Department at the addresses below, and **forwarded to the Department** for its review and transmittal to CSXT. No work will be permitted by CSXT on its right-of-way until it has reviewed and approved the evidence of insurance required herein.

# BP-87

Project I-5793

Davidson County

DEPARTMENT:

Department of Transportation  
Rail Division  
C/O Meredith McLamb, State Railroad Agent  
1556 Mail Service Center  
Raleigh NC 27699-1556

RAILROAD:

CSX Transportation, Inc.  
Risk Management (C-907)  
500 Water Street  
Jacksonville, FL 32202

- C. Contractor must submit the complete Railroad Protective Liability policy, Certificates of Insurance and all notices and correspondence regarding the insurance policies in an electronic format to:

[insurancedocuments@csx.com](mailto:insurancedocuments@csx.com)

- D. The insurance required herein shall in no way serve to limit the liability of Department or its Contractors under the terms of this agreement.
- E. No extra allowance will be made for the insurance required hereunder; the entire cost of same is to be included in the unit contract price bids for the several pay items.

County : Davidson

Line #	Item Number	Sec #	Description	Quantity	Unit Cost	Amount
<b>ROADWAY ITEMS</b>						
0001	0000100000-N	800	MOBILIZATION	Lump Sum	L.S.	
0002	0036000000-E	225	UNDERCUT EXCAVATION	1,000 CY		
0003	0106000000-E	230	BORROW EXCAVATION	894 CY		
0004	0196000000-E	270	GEOTEXTILE FOR SOIL STABILIZATION	5,000 SY		
0005	0241000000-E	SP	GENERIC GRADING ITEM 7" TRENCHING FOR SHOULDER CONSTRUCTION	31,443 SY		
0006	0241000000-E	SP	GENERIC GRADING ITEM 8" TRENCHING FOR SHOULDER CONSTRUCTION	74,848 SY		
0007	1022000000-E	SP	SEALING EXISTING PAVEMENT CRACKS	35,000 LB		
0008	1220000000-E	545	INCIDENTAL STONE BASE	500 TON		
0009	1245000000-E	SP	SHOULDER RECONSTRUCTION	27.01 SMI		
0010	1297000000-E	607	MILLING ASPHALT PAVEMENT, **** DEPTH (7")	15,559 SY		
0011	1491000000-E	610	ASPHALT CONC BASE COURSE, TYPE B25.0C	12,524 TON		
0012	1523000000-E	610	ASPHALT CONC SURFACE COURSE, TYPE S9.5C	3,111 TON		
0013	1575000000-E	620	ASPHALT BINDER FOR PLANT MIX	734 TON		
0014	1735000000-E	723	REPAIR OF JOINTED CONCRETE PAVEMENT SLABS	866 SY		
0015	1736000000-E	723	SELECT MATERIAL, CLASS IV	500 TON		
0016	1840000000-E	665	MILLED RUMBLE STRIPS (ASPHALT CONCRETE)	70,746 LF		
0017	1881000000-E	SP	GENERIC PAVING ITEM JOINT CONSTRUCTION, REPAIR & SEALING	598,896 LF		

County : Davidson

Line #	Item Number	Sec #	Description	Quantity	Unit Cost	Amount
0018	1891000000-E	SP	GENERIC PAVING ITEM DIAMOND GRINDING PCC PAVEMENT	374,309	SY	
0019	1925000000-E	730	MILLED RUMBLE STRIPS (CONCRETE SHOULDERS)	72,537	LF	
0020	2738000000-E	SP	GENERIC PAVING ITEM ROLLER COMPACTED CONCRETE	74,848	SY	
0021	2762000000-E	SP	GENERIC PAVING ITEM PAVEMENT SLAB STABILIZATION MATERIAL	21,000	LB	
0022	2762000000-E	SP	GENERIC PAVING ITEM SEALING EXISTING PAVEMENT CRACKS (POLYMER PATCH)	250	LB	
0023	4400000000-E	1110	WORK ZONE SIGNS (STATIONARY)	350	SF	
0024	4405000000-E	1110	WORK ZONE SIGNS (PORTABLE)	700	SF	
0025	4410000000-E	1110	WORK ZONE SIGNS (BARRICADE MOUNTED)	26	SF	
0026	4415000000-N	1115	FLASHING ARROW BOARD	3	EA	
0027	4420000000-N	1120	PORTABLE CHANGEABLE MESSAGE SIGN	3	EA	
0028	4422000000-N	1120	PORTABLE CHANGEABLE MESSAGE SIGN (SHORT TERM)	60	DAY	
0029	4423000000-N	SP	WORK ZONE DIGITAL SPEED LIMIT SIGNS	5	EA	
0030	4424000000-N	SP	WORK ZONE PRESENCE LIGHTING	15	EA	
0031	4430000000-N	1130	DRUMS	362	EA	
0032	4434000000-N	SP	SEQUENTIAL FLASHING WARNING LIGHTS	42	EA	
0033	4445000000-E	1145	BARRICADES (TYPE III)	64	LF	
0034	4480000000-N	1165	TMA	4	EA	

County : Davidson

Line #	Item Number	Sec #	Description	Quantity	Unit Cost	Amount
0035	4510000000-N	1190	LAW ENFORCEMENT	470	HR	
0036	4805000000-N	1205	COLD APPLIED PLASTIC PAVEMENT MARKING SYMBOL, TYPE ** (II)	10	EA	
0037	4815000000-E	1205	PAINT PAVEMENT MARKING LINES (6")	182,764	LF	
0038	4825000000-E	1205	PAINT PAVEMENT MARKING LINES (12")	9,222	LF	
0039	4845000000-N	1205	PAINT PAVEMENT MARKING SYMBOL	10	EA	
0040	4847030000-E	1205	POLYUREA PAVEMENT MARKING LINES (6", 20 MILS)	182,764	LF	
0041	4847070000-E	1205	POLYUREA PAVEMENT MARKING LINES (12", 20 MILS)	9,222	LF	
0042	4855000000-E	1205	REMOVAL OF PAVEMENT MARKING LINES (6")	182,764	LF	
0043	4865000000-E	1205	REMOVAL OF PAVEMENT MARKING LINES (12")	9,222	LF	
0044	4875000000-N	1205	REMOVAL OF PAVEMENT MARKING SYMBOLS & CHARACTERS	10	EA	
0045	4905000000-N	1253	SNOWPLOWABLE PAVEMENT MARKERS	2,565	EA	
0046	5255000000-N	1413	PORTABLE LIGHTING	Lump Sum	L.S.	
0047	6000000000-E	1605	TEMPORARY SILT FENCE	2,980	LF	
0048	6071010000-E	SP	WATTLE	298	LF	
0049	6084000000-E	1660	SEEDING & MULCHING	1	ACR	

---

**STRUCTURE ITEMS**

---

0050	8296000000-N	442	POLLUTION CONTROL	Lump Sum	L.S.	
------	--------------	-----	-------------------	----------	------	--

---

County : Davidson

Line #	Item Number	Sec #	Description	Quantity	Unit Cost	Amount
0051	8664000000-E	SP	SHOTCRETE REPAIRS	188.7 CF		
0052	8692000000-N	SP	FOAM JOINT SEALS	Lump Sum	L.S.	
0053	8860000000-N	SP	GENERIC STRUCTURE ITEM PAINTING CONTAINMENT FOR BRIDGE NO 479	Lump Sum	L.S.	
0054	8860000000-N	SP	GENERIC STRUCTURE ITEM PAINTING CONTAINMENT FOR BRIDGE NO 480	Lump Sum	L.S.	
0055	8860000000-N	SP	GENERIC STRUCTURE ITEM PAINTING CONTAINMENT FOR BRIDGE NO 489	Lump Sum	L.S.	
0056	8860000000-N	SP	GENERIC STRUCTURE ITEM PAINTING CONTAINMENT FOR BRIDGE NO 493	Lump Sum	L.S.	
0057	8860000000-N	SP	GENERIC STRUCTURE ITEM PAINTING CONTAINMENT FOR BRIDGE NO 494	Lump Sum	L.S.	
0058	8860000000-N	SP	GENERIC STRUCTURE ITEM PAINTING CONTAINMENT FOR BRIDGE NO. 485	Lump Sum	L.S.	
0059	8860000000-N	SP	GENERIC STRUCTURE ITEM PAINTING CONTAINMENT FOR ZONE PAINTING FOR BRIDGE NO 474	Lump Sum	L.S.	
0060	8860000000-N	SP	GENERIC STRUCTURE ITEM PAINTING EXISTING WEATHERING STEEL STRUCTURE FOR BRIDGE NO 479	Lump Sum	L.S.	
0061	8860000000-N	SP	GENERIC STRUCTURE ITEM PAINTING EXISTING WEATHERING STEEL STRUCTURE FOR BRIDGE NO 480	Lump Sum	L.S.	
0062	8860000000-N	SP	GENERIC STRUCTURE ITEM PAINTING EXISTING WEATHERING STEEL STRUCTURE FOR BRIDGE NO 485	Lump Sum	L.S.	
0063	8860000000-N	SP	GENERIC STRUCTURE ITEM PAINTING EXISTING WEATHERING STEEL STRUCTURE FOR BRIDGE NO 489	Lump Sum	L.S.	

County : Davidson

Line #	Item Number	Sec #	Description	Quantity	Unit Cost	Amount
0064	8860000000-N	SP	GENERIC STRUCTURE ITEM PAINTING EXISTING WEATHERING STEEL STRUCTURE FOR BRIDGE NO 493	Lump Sum	L.S.	
0065	8860000000-N	SP	GENERIC STRUCTURE ITEM PAINTING EXISTING WEATHERING STEEL STRUCTURE FOR BRIDGE NO 494	Lump Sum	L.S.	
0066	8860000000-N	SP	GENERIC STRUCTURE ITEM ZONE PAINTING OF EXISTING STRUCTURE FOR BRIDGE NO 474	Lump Sum	L.S.	
0067	8867000000-E	SP	GENERIC STRUCTURE ITEM SILICONE JOINT SEALANT	1,499.9 LF		
0068	8882000000-E	SP	GENERIC STRUCTURE ITEM ELASTOMERIC CONCRETE	769.6 CF		
0069	8892000000-E	SP	GENERIC STRUCTURE ITEM BRIDGE JOINT DEMOLITION	3,107.9 SF		
0070	8892000000-E	SP	GENERIC STRUCTURE ITEM CONCRETE DECK REPAIR FOR EPOXY OVERLAY	60 SF		
0071	8892000000-E	SP	GENERIC STRUCTURE ITEM EPOXY OVERLAY SYSTEM	144,297.4 SF		
0072	8897000000-N	SP	GENERIC STRUCTURE ITEM CLEANING & PAINTING EXISTING BEARINGS WITH HRCSA FOR BRIDGE NO 474	48 EA		
0073	8897000000-N	SP	GENERIC STRUCTURE ITEM CLEANING & PAINTING EXISTING BEARINGS WITH HRCSA FOR BRIDGE NO 479	48 EA		
0074	8897000000-N	SP	GENERIC STRUCTURE ITEM CLEANING & PAINTING EXISTING BEARINGS WITH HRCSA FOR BRIDGE NO 480	48 EA		
0075	8897000000-N	SP	GENERIC STRUCTURE ITEM CLEANING & PAINTING EXISTING BEARINGS WITH HRCSA FOR BRIDGE NO 485	48 EA		



County : Davidson

Line #	Item Number	Sec #	Description	Quantity	Unit Cost	Amount
0076	8897000000-N	SP	GENERIC STRUCTURE ITEM CLEANING & PAINTING EXISTING BEARINGS WITH HRCSA FOR BRIDGE NO 489	80	EA	
0077	8897000000-N	SP	GENERIC STRUCTURE ITEM CLEANING & PAINTING EXISTING BEARINGS WITH HRCSA FOR BRIDGE NO 493	48	EA	
0078	8897000000-N	SP	GENERIC STRUCTURE ITEM CLEANING & PAINTING EXISTING BEARINGS WITH HRCSA FOR BRIDGE NO 494	48	EA	
			<b>Total Amount Of Bid For Entire Project :</b>			

1408/Nov30/Q2128837.51/D415371210000/E78

DBE GOAL SET: 9.00%  
DBE GOAL OBT: 9.03%

Vendor 1 of 1: TRIANGLE GRADING & PAVING INC (3752)  
Call Order 009 (Proposal: C204053)

### Bid Information

---

<b>Proposal County:</b> DAVIDSON	<b>Bid Checksum:</b> 67300501
<b>Vendor Address:</b> PO Drawer 2570 Burlington , NC , 27215	<b>Bid Total:</b> \$17,171,809.92
<b>Signature Check:</b> Gray_Kirkpatrick_3752	<b>Items Total:</b> \$17,171,809.92
<b>Time Bid Received:</b> January 16, 2018 01:56 PM	<b>Time Total:</b> \$0.00
<b>Amendment Count:</b> 0	

**Bidding Errors:**  
None.

Vendor 1 of 1: TRIANGLE GRADING & PAVING INC (3752)  
Call Order 009 (Proposal: C204053)

Bid Bond Information

---

<b>Projects:</b>	<b>Bond Maximum:</b>
<b>Counties:</b>	<b>State of Incorporation:</b>
<b>Bond ID:</b> 9XQ4-N8YB-HKKT-BJUF	<b>Agency Execution Date:</b> 1/16/2018
<b>Paid by Check:</b> No	<b>Surety Name:</b> SurePathNetwork
<b>Bond Percent:</b> 5%	<b>Bond Agency Name:</b> Zurich American Insurance Company

Bidder 1 of 1

Vendor 3752's Bid Information for Call 009, Letting L180116, 01/16/18

Triangle Grading & Paving, Inc. (3752)  
 Call Order 009 (Proposal ID C204053)

LIST OF DBE PARTICIPANTS

VENDOR NUMBER	DBE NAME ADDRESS	WORK CODE TYPE OF WORK	CERT TYPE AMOUNT	
WB 3765	STAY ALERT SAFETY SERVICES INC POST OFFICE BOX 467 , KERNERSVILLE, NC 27285		Sub 101,036.42	COMMITTED
WB 12345	D M CONLON INC DAN-KEL CONCRETE P.O. BOX 7127 , MYRTLE BEACH, SC 29572		Sub 914,321.92	COMMITTED
WB 5796	A1 PAVEMENT MARKING LLC 238 N BIVENS RD , MONROE, NC 28110		Sub 431,973.90	COMMITTED
WB 2976	CAROLINA ENVIRONMENTAL CONTRACT POST OFFICE BOX 1905 , MT. AIRY, NC 27030		Sub 11,622.00	COMMITTED
MB 11572	CRUZ BROTHERS CONCRETE, INC. 1572 PAYNE ROAD/LOT 75 LOT 75 , GRAHAM, NC 27253		Sub 21,650.00	COMMITTED
MB 10588	W & W TRUCKING & DEMOLITION SER 3221 CARVER SCHOOL RD , WINSTON SALEM, NC 271054752		Sub 70,000.00	COMMITTED
			TOTAL: \$1,550,604.24	
			9.03%	

Vendor 3752's Bid Information for Call 009, Letting L180116, 01/16/18

Triangle Grading & Paving, Inc. (3752)  
 Call Order 009 (Proposal ID C204053)

Miscellaneous Data Info - Contractor Responses:

=====

NON-COLLUSION AND DEBARMENT CERTIFICATION

Explanation of the prospective bidder that is unable to certify to any of the statements in this certification:

Explanation:  
 NOT ANSWERED  
 NOT ANSWERED  
 NOT ANSWERED  
 NOT ANSWERED

AWARD LIMITS ON MULTIPLE PROJECTS

By answering YES to this statement, the bidder acknowledges that they are using the award limits on multiple projects. No

It is the desire of the Bidder to be awarded contracts, the value of which will not exceed a total of NOT ANSWERED for those projects indicated herein, for which bids will be opened on (MM/DD/YY)

The Award Limits shall apply to the following projects:

Contract Number	County
NOT ANSWERED	
NOT ANSWERED	
NOT ANSWERED	
NOT ANSWERED	

Bidder 1 of 1

NOT ANSWERED  
NOT ANSWERED

Bid Bond Data Info - Contractor Responses:

=====

BondID: 9XQ4-N8YB-HKKT-BJUF  
Surety Registry Agency: SurePathNetwork  
Verified?: Yes  
Surety Agency: Zurich American Insurance Company  
Bond Execution Date: 1/16/2018  
Bond Amount: \$858,590.50 (Five Percent of Bid)

Dept of Transportation

Revised:

Contract ID: C204053

Project(s): NHPP-0085(017)

Letting Date: 01-16-18 Call Order: 009

Bidder: 3752 - Triangle Grading &amp; Paving, Inc.

Line No.	Item Description	Approx. Quantity and Units	Unit Price Dollars   Cts	Bid Amount Dollars   Ct
Section 0001 ROADWAY ITEMS				
Alt Group				
0001	0000100000-N MOBILIZATION	LUMP	LUMP	855,000.00
0002	0036000000-E UNDERCUT EXCAVATION	1,000.000 CY	20.00000	20,000.00
0003	0106000000-E BORROW EXCAVATION	894.000 CY	30.00000	26,820.00
0004	0196000000-E GEOTEXTILE FOR SOIL STABILIZATION	5,000.000 SY	2.00000	10,000.00
0005	0241000000-E GENERIC GRADING ITEM 7" TRENCHING FOR SHOULDER CONSTRUCTION	31,443.000 SY	12.00000	377,316.00
0006	0241000000-E GENERIC GRADING ITEM 8" TRENCHING FOR SHOULDER CONSTRUCTION	74,848.000 SY	13.50000	1,010,448.00
0007	1022000000-E SEALING EXISTING PAVEMENT CRACKS	35,000.000 LB	5.00000	175,000.00
0008	1220000000-E INCIDENTAL STONE BASE	500.000 TON	30.00000	15,000.00
0009	1245000000-E SHOULDER RECONSTRUCTION	27.010 SMI	12,000.00000	324,120.00
0010	1297000000-E MILLING ASPHALT PAVEMENT, ***"DEPTH (7")	15,559.000 SY	8.00000	124,472.00
0011	1491000000-E ASPHALT CONC BASE COURSE, TYPE B25.0C	12,524.000 TON	70.00000	876,680.00

Dept of Transportation

Revised:

Contract ID: C204053

Project(s): NHPP-0085(017)

Letting Date: 01-16-18 Call Order: 009

Bidder: 3752 - Triangle Grading &amp; Paving, Inc.

Line No.	Item Description	Approx. Quantity and Units	Unit Price Dollars   Cts	Bid Amount Dollars   Ct
0012	1523000000-E ASPHALT CONC SURFACE COURSE, TYPE S9.5C	3,111.000 TON	75.00000	233,325.00
0013	1575000000-E ASPHALT BINDER FOR PLANT MIX	734.000 TON	450.00000	330,300.00
0014	1735000000-E REPAIR OF JOINTED CONCRETE PAVEMENT SLABS	866.000 SY	850.00000	736,100.00
0015	1736000000-E SELECT MATERIAL, CLASS IV	500.000 TON	30.00000	15,000.00
0016	1840000000-E MILLED RUMBLE STRIPS (ASPHALT CONCRETE)	70,746.000 LF	0.25000	17,686.50
0017	1881000000-E GENERIC PAVING ITEM JOINT CONSTRUCTION, REPAIR & SEALING	598,896.000 LF	1.80000	1,078,012.80
0018	1891000000-E GENERIC PAVING ITEM DIAMOND GRINDING PCC PAVEMENT	374,309.000 SY	4.25000	1,590,813.25
0019	1925000000-E MILLED RUMBLE STRIPS (CONCRETE SHOULDERS)	72,537.000 LF	0.45000	32,641.65
0020	2738000000-E GENERIC PAVING ITEM ROLLER COMPACTED CONCRETE	74,848.000 SY	38.00000	2,844,224.00
0021	2762000000-E GENERIC PAVING ITEM PAVEMENT SLAB STABILIZATION MATERIAL	21,000.000 LB	10.00000	210,000.00
0022	2762000000-E GENERIC PAVING ITEM SEALING EXISTING PAVEMENT CRACKS (POLYMER PATCH)	250.000 LB	20.00000	5,000.00

Dept of Transportation

Revised:

Contract ID: C204053

Project(s): NHPP-0085(017)

Letting Date: 01-16-18 Call Order: 009

Bidder: 3752 - Triangle Grading &amp; Paving, Inc.

Line No.	Item Description	Approx. Quantity and Units	Unit Price		Bid Amount	
			Dollars	Cts	Dollars	Ct
0023	4400000000-E WORK ZONE SIGNS (STATIONARY)	350.000	7.25000		2,537.50	
		SF				
0024	4405000000-E WORK ZONE SIGNS (PORTABLE)	700.000	9.47000		6,629.00	
		SF				
0025	4410000000-E WORK ZONE SIGNS (BARRICADE MOUNTED)	26.000	7.92000		205.92	
		SF				
0026	4415000000-N FLASHING ARROW BOARD	3.000	5,000.00000		15,000.00	
		EA				
0027	4420000000-N PORTABLE CHANGEABLE MESSAGE SIGN	3.000	10,000.00000		30,000.00	
		EA				
0028	4422000000-N PORTABLE CHANGEABLE MESSAGE SIGN (SHORT TERM)	60.000	45.00000		2,700.00	
		DAY				
0029	4423000000-N WORK ZONE DIGITAL SPEED LIMIT SIGNS	5.000	5,100.00000		25,500.00	
		EA				
0030	4424000000-N WORK ZONE PRESENCE LIGHTING	15.000	3,950.00000		59,250.00	
		EA				
0031	4430000000-N DRUMS	362.000	110.00000		39,820.00	
		EA				
0032	4434000000-N SEQUENTIAL FLASHING WARNING LIGHTS	42.000	125.00000		5,250.00	
		EA				
0033	4445000000-E BARRICADES (TYPE III)	64.000	26.00000		1,664.00	
		LF				
0034	4480000000-N TMA	4.000	25,000.00000		100,000.00	
		EA				



Dept of Transportation

Revised:

Contract ID: C204053

Project(s): NHPP-0085(017)

Letting Date: 01-16-18 Call Order: 009

Bidder: 3752 - Triangle Grading &amp; Paving, Inc.

Line No.	Item Description	Approx. Quantity and Units	Unit Price Dollars   Cts	Bid Amount Dollars   Ct
0035	4510000000-N LAW ENFORCEMENT	470.000	50.00000	23,500.00
		HR		
0036	4805000000-N COLD APPLIED PLASTIC PAVEMENT MARKING SYMBOL, TYPE ** (II)	10.000	1,850.00000	18,500.00
		EA		
0037	4815000000-E PAINT PAVEMENT MARKING LINES (6")	182,764.000	0.30000	54,829.20
		LF		
0038	4825000000-E PAINT PAVEMENT MARKING LINES (12")	9,222.000	0.60000	5,533.20
		LF		
0039	4845000000-N PAINT PAVEMENT MARKING SYMBOL	10.000	100.00000	1,000.00
		EA		
0040	4847030000-E POLYUREA PAVEMENT MARKING LINES (6", 20 MILS)	182,764.000	0.90000	164,487.60
		LF		
0041	4847070000-E POLYUREA PAVEMENT MARKING LINES (12", 20 MILS)	9,222.000	1.65000	15,216.30
		LF		
0042	4855000000-E REMOVAL OF PAVEMENT MARKING LINES (6")	182,764.000	0.40000	73,105.60
		LF		
0043	4865000000-E REMOVAL OF PAVEMENT MARKING LINES (12")	9,222.000	1.00000	9,222.00
		LF		
0044	4875000000-N REMOVAL OF PAVEMENT MARKING SYMBOLS & CHARACTERS	10.000	50.00000	500.00
		EA		
0045	4905000000-N SNOWPLOWABLE PAVEMENT MARKERS	2,565.000	32.00000	82,080.00
		EA		

Dept of Transportation

Revised:

Contract ID: C204053

Project(s): NHPP-0085(017)

Letting Date: 01-16-18 Call Order: 009

Bidder: 3752 - Triangle Grading &amp; Paving, Inc.

Line No.	Item Description	Approx. Quantity and Units	Unit Price Dollars   Cts	Bid Amount Dollars   Ct
0046	5255000000-N PORTABLE LIGHTING	LUMP	LUMP	2,500,000.00
0047	6000000000-E TEMPORARY SILT FENCE	2,980.000 LF	3.00000	8,940.00
0048	6071010000-E WATTLE	298.000 LF	9.00000	2,682.00
0049	6084000000-E SEEDING & MULCHING	1.000 ACR	10,000.00000	10,000.00
Section 0001 Total				14,166,111.52

Section 0004 STRUCTURE ITEMS

## Alt Group

0050	8296000000-N POLLUTION CONTROL	LUMP	LUMP	25,000.00
0051	8664000000-E SHOTCRETE REPAIRS	188.700 CF	1,500.00000	283,050.00
0052	8692000000-N FOAM JOINT SEALS	LUMP	LUMP	125,000.00
0053	8860000000-N GENERIC STRUCTURE ITEM PAINTING CONTAINMENT FOR BRIDGE NO 479	LUMP	LUMP	50,000.00
0054	8860000000-N GENERIC STRUCTURE ITEM PAINTING CONTAINMENT FOR BRIDGE NO 480	LUMP	LUMP	50,000.00

Dept of Transportation

Revised:

Contract ID: C204053

Project(s): NHPP-0085(017)

Letting Date: 01-16-18 Call Order: 009

Bidder: 3752 - Triangle Grading &amp; Paving, Inc.

Line No.	Item Description	Approx. Quantity and Units	Unit Price Dollars   Cts	Bid Amount Dollars   Ct
0055	8860000000-N GENERIC STRUCTURE ITEM PAINTING CONTAINMENT FOR BRIDGE NO 489	LUMP	LUMP	65,000.00
0056	8860000000-N GENERIC STRUCTURE ITEM PAINTING CONTAINMENT FOR BRIDGE NO 493	LUMP	LUMP	65,000.00
0057	8860000000-N GENERIC STRUCTURE ITEM PAINTING CONTAINMENT FOR BRIDGE NO 494	LUMP	LUMP	40,000.00
0058	8860000000-N GENERIC STRUCTURE ITEM PAINTING CONTAINMENT FOR BRIDGE NO. 485	LUMP	LUMP	40,000.00
0059	8860000000-N GENERIC STRUCTURE ITEM PAINTING CONTAINMENT FOR ZONE PAINTING FOR BRIDGE NO 474	LUMP	LUMP	50,000.00
0060	8860000000-N GENERIC STRUCTURE ITEM PAINTING EXISTING WEATHERING STEEL STRUCTURE FOR BRIDGE NO 479	LUMP	LUMP	80,000.00
0061	8860000000-N GENERIC STRUCTURE ITEM PAINTING EXISTING WEATHERING STEEL STRUCTURE FOR BRIDGE NO 480	LUMP	LUMP	80,000.00
0062	8860000000-N GENERIC STRUCTURE ITEM PAINTING EXISTING WEATHERING STEEL STRUCTURE FOR BRIDGE NO 485	LUMP	LUMP	95,000.00

Dept of Transportation

Revised:

Contract ID: C204053

Project(s): NHPP-0085(017)

Letting Date: 01-16-18 Call Order: 009

Bidder: 3752 - Triangle Grading &amp; Paving, Inc.

Line No.	Item Description	Approx. Quantity and Units	Unit Price Dollars   Cts	Bid Amount Dollars   Ct
0063	8860000000-N GENERIC STRUCTURE ITEM PAINTING EXISTING WEATHERING STEEL STRUCTURE FOR BRIDGE NO 489	LUMP	LUMP	65,000.00
0064	8860000000-N GENERIC STRUCTURE ITEM PAINTING EXISTING WEATHERING STEEL STRUCTURE FOR BRIDGE NO 493	LUMP	LUMP	55,000.00
0065	8860000000-N GENERIC STRUCTURE ITEM PAINTING EXISTING WEATHERING STEEL STRUCTURE FOR BRIDGE NO 494	LUMP	LUMP	55,000.00
0066	8860000000-N GENERIC STRUCTURE ITEM ZONE PAINTING OF EXISTING STRUCTURE FOR BRIDGE NO 474	LUMP	LUMP	25,000.00
0067	8867000000-E GENERIC STRUCTURE ITEM SILICONE JOINT SEALANT	1,499.900 LF	60.00000	89,994.00
0068	8882000000-E GENERIC STRUCTURE ITEM ELASTOMERIC CONCRETE	769.600 CF	300.00000	230,880.00
0069	8892000000-E GENERIC STRUCTURE ITEM BRIDGE JOINT DEMOLITION	3,107.900 SF	100.00000	310,790.00
0070	8892000000-E GENERIC STRUCTURE ITEM CONCRETE DECK REPAIR FOR EPOXY OVERLAY	60.000 SF	350.00000	21,000.00
0071	8892000000-E GENERIC STRUCTURE ITEM EPOXY OVERLAY SYSTEM	144,297.400 SF	6.00000	865,784.40

Dept of Transportation

Revised:

Contract ID: C204053

Project(s): NHPP-0085(017)

Letting Date: 01-16-18 Call Order: 009

Bidder: 3752 - Triangle Grading &amp; Paving, Inc.

Line No.	Item Description	Approx. Quantity and Units	Unit Price Dollars   Cts	Bid Amount Dollars   Ct
0072	8897000000-N GENERIC STRUCTURE ITEM CLEANING & PAINTING EXISTING BEARINGS WITH HRCSA FOR BRIDGE NO 474	48.000 EA	650.00000	31,200.00
0073	8897000000-N GENERIC STRUCTURE ITEM CLEANING & PAINTING EXISTING BEARINGS WITH HRCSA FOR BRIDGE NO 479	48.000 EA	650.00000	31,200.00
0074	8897000000-N GENERIC STRUCTURE ITEM CLEANING & PAINTING EXISTING BEARINGS WITH HRCSA FOR BRIDGE NO 480	48.000 EA	650.00000	31,200.00
0075	8897000000-N GENERIC STRUCTURE ITEM CLEANING & PAINTING EXISTING BEARINGS WITH HRCSA FOR BRIDGE NO 485	48.000 EA	650.00000	31,200.00
0076	8897000000-N GENERIC STRUCTURE ITEM CLEANING & PAINTING EXISTING BEARINGS WITH HRCSA FOR BRIDGE NO 489	80.000 EA	650.00000	52,000.00
0077	8897000000-N GENERIC STRUCTURE ITEM CLEANING & PAINTING EXISTING BEARINGS WITH HRCSA FOR BRIDGE NO 493	48.000 EA	650.00000	31,200.00
0078	8897000000-N GENERIC STRUCTURE ITEM CLEANING & PAINTING EXISTING BEARINGS WITH HRCSA FOR BRIDGE NO 494	48.000 EA	650.00000	31,200.00
	Section 0004 Total			3,005,698.40
	Bid Total			17,171,809.92

NON-COLLUSION AND DEBARMENT CERTIFICATION

The bidder certifies that neither he, nor any official, agent or employee of the bidder has entered into any agreement, participated in any collusion, or otherwise taken any action which is in restraint of free competitive bidding in connection with this bid, and that the bidder intends to do the work with its own bonafide employees or subcontractors and is not bidding for the benefit of another contractor. In addition, submitting this electronic bid constitutes the bidder's certification of Status under penalty of perjury under the laws of the United States and in accordance with the Debarment Certification on file with the Department.

By submitting this bid, the bidder certifies to the best of his knowledge and belief that he and his principals:

- a. Are not presently debarred, suspended, proposed for debarment, declared ineligible, or voluntarily excluded from covered transactions by any Federal department or agency;
- b. Have not within a three-year period preceding this proposal been convicted of or had a civil judgment rendered against them for commission of fraud or a criminal offense in connection with obtaining, attempting to obtain, or performing a public (Federal, State or local) transaction or contract under a public transaction; violation of Federal or State antitrust statutes or commission of embezzlement, theft, forgery, bribery, falsification or destruction of records; making false statements; or receiving stolen property;
- c. Are not presently indicted for or otherwise criminally or civilly charged by a governmental entity (Federal, State or local) with commission of any of the offenses enumerated in paragraph b. of this certification; and
- d. Have not within a three-year period preceding this proposal had one or more public transactions (Federal, State or local) terminated for cause or default.

Where the prospective bidder is unable to certify to any of the statements in this certification, the bidder shall submit an explanation in the blanks provided herein. The explanation will not necessarily result in denial of participation in a contract.

Explanation:  
NOT ANSWERED  
NOT ANSWERED  
NOT ANSWERED  
NOT ANSWERED

If the prequalified bidder's status changes, he shall immediately submit a new fully executed non-collusion affidavit and debarment certification with an explanation of the change to the Contract Office prior to submitting the bid.

Failure to furnish a certification or an explanation will be grounds for rejection of a bid

AWARD LIMITS ON MULTIPLE PROJECTS

By answering YES to this statement, the bidder acknowledges that they are using the award limits on multiple projects. No

A bidder who desires to bid on more than one project on which bids are to be opened on the same date, and who also desires to avoid receiving an award of more projects than he is equipped to handle, may bid on any number of projects but may limit the total amount of work awarded to him on selected projects by completing the AWARD LIMITS ON MULTIPLE PROJECTS.

The Award Limits on Multiple Projects must be filled in on each project bid for which the Bidder desires protection.

It is the desire of the Bidder to be awarded contracts, the value of which will not exceed a total of NOT ANSWERED for those projects indicated herein, for which bids will be opened on (MM/DD/YY)

The Award Limits shall apply to the following projects:

Contract Number	County
NOT ANSWERED	
NOT ANSWERED	
NOT ANSWERED	
NOT ANSWERED	
NOT ANSWERED	
NOT ANSWERED	

It is agreed that if I am (we are) the low Bidder(s) on indicated projects, the total value of which is more than the above stipulated award limits, the Board of Transportation will award me (us) projects from among those indicated that have a total value not to exceed the award limit and will result in the lowest total bids to the Department of Transportation.

PROPOSAL: C204053  
 LETTING: L180116 CALL: 009  
 VENDOR: 3752 Triangle Grading & Paving, Inc.

LINE NO.	ITEM NO.	ITEM DESC.	UNIT TYPE	SUBCONTRACTOR QUANTITY	SUBCONTRACTOR UNIT PRICE	EXTENDED AMOUNT
DBE SUBCONTRACTOR: 3765 STAY ALERT SAFETY SERVICES INC						
Will Use Quote: Yes						
0023	4400000000-E	WORK ZONE SI SF		350.000	7.25000	2537.50
0024	4405000000-E	WORK ZONE SI SF		700.000	9.47000	6629.00
0025	4410000000-E	WORK ZONE SI SF		26.000	7.92000	205.92
0029	4423000000-N	WZ DIGITAL S EA		5.000	5100.00000	25500.00
0030	4424000000-N	WZ PRESENCE EA		15.000	3950.00000	59250.00
0032	4434000000-N	SEQ FLASH WA EA		42.000	125.00000	5250.00
0033	4445000000-E	BARRICADES ( LF		64.000	26.00000	1664.00
DBE COMMITMENT TOTAL FOR SUBCONTRACTOR:						101,036.42
DBE COMMITMENT TOTAL FOR VENDOR (SubContractor )						101,036

DBE SUBCONTRACTOR: 12345 D M CONLON INC DAN-KEL CONCRETE CUTTING						
Will Use Quote: Yes						
0017	1881000000-E	GENERIC PAVI LF		598896.000	1.52000	910321.92
0001	0000100000-N	MOBILIZATION LS		1.000	4000.00000	4000.00
DBE COMMITMENT TOTAL FOR SUBCONTRACTOR:						914,321.92
DBE COMMITMENT TOTAL FOR VENDOR (SubContractor )						914,321

DBE SUBCONTRACTOR: 5796 A1 PAVEMENT MARKING LLC						
Will Use Quote: Yes						
0036	4805000000-N	COLD APPL PL EA		10.000	1850.00000	18500.00
0037	4815000000-E	PAINT PVMT M LF		182764.000	0.30000	54829.20
0038	4825000000-E	PAINT PVMT M LF		9222.000	0.60000	5533.20
0039	4845000000-N	PAINT PVT MK EA		10.000	100.00000	1000.00
0040	4847030000-E	POLYUREA LIN LF		182764.000	0.90000	164487.60
0041	4847070000-E	POLYUREA LIN LF		9222.000	1.65000	15216.30
0042	4855000000-E	LINE REMOVAL LF		182764.000	0.40000	73105.60
0043	4865000000-E	LINE REMOVAL LF		9222.000	1.00000	9222.00
0044	4875000000-N	REMOVAL OF S EA		10.000	50.00000	500.00
0045	4905000000-N	SNOWPLB PVMT EA		2565.000	32.00000	82080.00
0001	0000100000-N	MOBILIZATION LS		1.000	7500.00000	7500.00
DBE COMMITMENT TOTAL FOR SUBCONTRACTOR:						431,973.90
DBE COMMITMENT TOTAL FOR VENDOR (SubContractor )						431,973

DBE SUBCONTRACTOR: 2976 CAROLINA ENVIRONMENTAL CONTRACTING INC						
Will Use Quote: Yes						
0047	6000000000-E	TEMPORARY SI LF		2980.000	3.00000	8940.00
0048	6071010000-E	WATTLE LF		298.000	9.00000	2682.00



---

LINE NO.	ITEM NO.	ITEM DESC.	UNIT TYPE	SUBCONTRACTOR QUANTITY	SUBCONTRACTOR UNIT PRICE	EXTENDED AMOUNT
----------	----------	------------	-----------	------------------------	--------------------------	-----------------

---

DBE COMMITMENT TOTAL FOR SUBCONTRACTOR: 11,622.00  
DBE COMMITMENT TOTAL FOR VENDOR (SubContractor ) 11,622.

DBE SUBCONTRACTOR: 11572 CRUZ BROTHERS CONCRETE, INC.  
Will Use Quote: Yes

0014	1735000000-E	REP JNT CONC SY		866.000	25.00000	21650.00
		Pouring Service				

DBE COMMITMENT TOTAL FOR SUBCONTRACTOR: 21,650.00  
DBE COMMITMENT TOTAL FOR VENDOR (SubContractor ) 21,650.

DBE SUBCONTRACTOR: 10588 W & W TRUCKING & DEMOLITION SERVICES LLC  
Will Use Quote: Yes

0005	0241000000-E	GENERIC GRAD SY		20000.000	1.00000	20000.00
		Haul by the hour.				
0006	0241000000-E	GENERIC GRAD SY		50000.000	1.00000	50000.00
		HAul by the hour				

DBE COMMITMENT TOTAL FOR SUBCONTRACTOR: 70,000.00  
DBE COMMITMENT TOTAL FOR VENDOR (SubContractor ) 70,000.

TOTAL DBE COMMITMENT FOR VENDOR: Entered: 9.03% or 1550604.24  
Required: 9.00% or 1545462.89  
<GOAL MET>

THIS PROPOSAL CONTAINS THE FOLLOWING ERRORS/WARNINGS (IF ANY)

This Bid contains 0 amendment files

Electronic Bid Submission

By submitting this bid electronically, I hereby acknowledge that all requirements included in the hard copy proposal, addendum, amendments, plans, standard specifications, supplemental specifications and special provisions are part of the bid and contract. Further, I acknowledge that I have read, understand, accept, acknowledge and agree to comply with all statements in this electronic bid.

I Hereby certify that I have the authority to submit this bid.

Signature

Agency

Date

-----  
-----  
-----

## Contract Item Sheets For C204053

Line #	ItemNumber	Sec #	Description	Quantity Unit	Unit Bid Price	Amount Bid
<b>ROADWAY ITEMS</b>						
0001	0000100000-N	800	MOBILIZATION	Lump Sum LS	855,000.00	855,000.00
0002	0036000000-E	225	UNDERCUT EXCAVATION	1,000 CY	20.00	20,000.00
0003	0106000000-E	230	BORROW EXCAVATION	894 CY	30.00	26,820.00
0004	0196000000-E	270	GEOTEXTILE FOR SOIL STABILIZATION	5,000 SY	2.00	10,000.00
0005	0241000000-E	SP	GENERIC GRADING ITEM 7" TRENCHING FOR SHOULDER CONSTRUCTION	31,443 SY	12.00	377,316.00
0006	0241000000-E	SP	GENERIC GRADING ITEM 8" TRENCHING FOR SHOULDER CONSTRUCTION	74,848 SY	13.50	1,010,448.00
0007	1022000000-E	SP	SEALING EXISTING PAVEMENT CRACKS	35,000 LB	5.00	175,000.00
0008	1220000000-E	545	INCIDENTAL STONE BASE	500 TON	30.00	15,000.00
0009	1245000000-E	SP	SHOULDER RECONSTRUCTION	27.01 SMI	12,000.00	324,120.00
0010	1297000000-E	607	MILLING ASPHALT PAVEMENT, **** DEPTH (7")	15,559 SY	8.00	124,472.00
0011	1491000000-E	610	ASPHALT CONC BASE COURSE, TYPE B25.0C	12,524 TON	70.00	876,680.00
0012	1523000000-E	610	ASPHALT CONC SURFACE COURSE, TYPE S9.5C	3,111 TON	75.00	233,325.00
0013	1575000000-E	620	ASPHALT BINDER FOR PLANT MIX	734 TON	450.00	330,300.00
0014	1735000000-E	723	REPAIR OF JOINTED CONCRETE PAVEMENT SLABS	866 SY	850.00	736,100.00
0015	1736000000-E	723	SELECT MATERIAL, CLASS IV	500 TON	30.00	15,000.00
0016	1840000000-E	665	MILLED RUMBLE STRIPS (ASPHALT CONCRETE)	70,746 LF	0.25	17,686.50
0017	1881000000-E	SP	GENERIC PAVING ITEM JOINT CONSTRUCTION, REPAIR & SEALING	598,896 LF	1.80	1,078,012.80

Line #	ItemNumber	Sec #	Description	Quantity Unit	Unit Bid Price	Amount Bid
0018	1891000000-E	SP	GENERIC PAVING ITEM DIAMOND GRINDING PCC PAVEMENT	374,309 SY	4.25	1,590,813.25
0019	1925000000-E	730	MILLED RUMBLE STRIPS (CONCRETE SHOULDERS)	72,537 LF	0.45	32,641.65
0020	2738000000-E	SP	GENERIC PAVING ITEM ROLLER COMPACTED CONCRETE	74,848 SY	38.00	2,844,224.00
0021	2762000000-E	SP	GENERIC PAVING ITEM PAVEMENT SLAB STABILIZATION MATERIAL	21,000 LB	10.00	210,000.00
0022	2762000000-E	SP	GENERIC PAVING ITEM SEALING EXISTING PAVEMENT CRACKS (POLYMER PATCH)	250 LB	20.00	5,000.00
0023	4400000000-E	1110	WORK ZONE SIGNS (STATIONARY)	350 SF	7.25	2,537.50
0024	4405000000-E	1110	WORK ZONE SIGNS (PORTABLE)	700 SF	9.47	6,629.00
0025	4410000000-E	1110	WORK ZONE SIGNS (BARRICADE MOUNTED)	26 SF	7.92	205.92
0026	4415000000-N	1115	FLASHING ARROW BOARD	3 EA	5,000.00	15,000.00
0027	4420000000-N	1120	PORTABLE CHANGEABLE MESSAGE SIGN	3 EA	10,000.00	30,000.00
0028	4422000000-N	1120	PORTABLE CHANGEABLE MESSAGE SIGN (SHORT TERM)	60 DAY	45.00	2,700.00
0029	4423000000-N	SP	WORK ZONE DIGITAL SPEED LIMIT SIGNS	5 EA	5,100.00	25,500.00
0030	4424000000-N	SP	WORK ZONE PRESENCE LIGHTING	15 EA	3,950.00	59,250.00
0031	4430000000-N	1130	DRUMS	362 EA	110.00	39,820.00
0032	4434000000-N	SP	SEQUENTIAL FLASHING WARNING LIGHTS	42 EA	125.00	5,250.00
0033	4445000000-E	1145	BARRICADES (TYPE III)	64 LF	26.00	1,664.00
0034	4480000000-N	1165	TMA	4 EA	25,000.00	100,000.00
0035	4510000000-N	1190	LAW ENFORCEMENT	470 HR	50.00	23,500.00

## Contract Item Sheets For C204053

Line #	ItemNumber	Sec #	Description	Quantity Unit	Unit Bid Price	Amount Bid
0036	4805000000-N	1205	COLD APPLIED PLASTIC PAVEMENT MARKING SYMBOL, TYPE ** (II)	10 EA	1,850.00	18,500.00
0037	4815000000-E	1205	PAINT PAVEMENT MARKING LINES (6")	182,764 LF	0.30	54,829.20
0038	4825000000-E	1205	PAINT PAVEMENT MARKING LINES (12")	9,222 LF	0.60	5,533.20
0039	4845000000-N	1205	PAINT PAVEMENT MARKING SYMBOL	10 EA	100.00	1,000.00
0040	4847030000-E	1205	POLYUREA PAVEMENT MARKING LINES (6", 20 MILS)	182,764 LF	0.90	164,487.60
0041	4847070000-E	1205	POLYUREA PAVEMENT MARKING LINES (12", 20 MILS)	9,222 LF	1.65	15,216.30
0042	4855000000-E	1205	REMOVAL OF PAVEMENT MARKING LINES (6")	182,764 LF	0.40	73,105.60
0043	4865000000-E	1205	REMOVAL OF PAVEMENT MARKING LINES (12")	9,222 LF	1.00	9,222.00
0044	4875000000-N	1205	REMOVAL OF PAVEMENT MARKING SYMBOLS & CHARACTERS	10 EA	50.00	500.00
0045	4905000000-N	1253	SNOWPLOWABLE PAVEMENT MARKERS	2,565 EA	32.00	82,080.00
0046	5255000000-N	1413	PORTABLE LIGHTING	Lump Sum LS	2,500,000.00	2,500,000.00
0047	6000000000-E	1605	TEMPORARY SILT FENCE	2,980 LF	3.00	8,940.00
0048	6071010000-E	SP	WATTLE	298 LF	9.00	2,682.00
0049	6084000000-E	1660	SEEDING & MULCHING	1 ACR	10,000.00	10,000.00

## Contract Item Sheets For C204053

Line #	ItemNumber	Sec #	Description	Quantity Unit	Unit Bid Price	Amount Bid
0050	8296000000-N	442	POLLUTION CONTROL	Lump Sum LS	25,000.00	25,000.00
0051	8664000000-E	SP	SHOTCRETE REPAIRS	188.7 CF	1,500.00	283,050.00
0052	8692000000-N	SP	FOAM JOINT SEALS	Lump Sum LS	125,000.00	125,000.00
0053	8860000000-N	SP	GENERIC STRUCTURE ITEM PAINTING CONTAINMENT FOR BRIDGE NO 479	Lump Sum LS	50,000.00	50,000.00
0054	8860000000-N	SP	GENERIC STRUCTURE ITEM PAINTING CONTAINMENT FOR BRIDGE NO 480	Lump Sum LS	50,000.00	50,000.00
0055	8860000000-N	SP	GENERIC STRUCTURE ITEM PAINTING CONTAINMENT FOR BRIDGE NO 489	Lump Sum LS	65,000.00	65,000.00
0056	8860000000-N	SP	GENERIC STRUCTURE ITEM PAINTING CONTAINMENT FOR BRIDGE NO 493	Lump Sum LS	65,000.00	65,000.00
0057	8860000000-N	SP	GENERIC STRUCTURE ITEM PAINTING CONTAINMENT FOR BRIDGE NO 494	Lump Sum LS	40,000.00	40,000.00
0058	8860000000-N	SP	GENERIC STRUCTURE ITEM PAINTING CONTAINMENT FOR BRIDGE NO. 485	Lump Sum LS	40,000.00	40,000.00
0059	8860000000-N	SP	GENERIC STRUCTURE ITEM PAINTING CONTAINMENT FOR ZONE PAINTING FOR BRIDGE NO 474	Lump Sum LS	50,000.00	50,000.00
0060	8860000000-N	SP	GENERIC STRUCTURE ITEM PAINTING EXISTING WEATHERING STEEL STRUCTURE FOR BRIDGE NO 479	Lump Sum LS	80,000.00	80,000.00
0061	8860000000-N	SP	GENERIC STRUCTURE ITEM PAINTING EXISTING WEATHERING STEEL STRUCTURE FOR BRIDGE NO 480	Lump Sum LS	80,000.00	80,000.00
0062	8860000000-N	SP	GENERIC STRUCTURE ITEM PAINTING EXISTING WEATHERING STEEL STRUCTURE FOR BRIDGE NO 485	Lump Sum LS	95,000.00	95,000.00
0063	8860000000-N	SP	GENERIC STRUCTURE ITEM PAINTING EXISTING WEATHERING STEEL STRUCTURE FOR BRIDGE NO 489	Lump Sum LS	65,000.00	65,000.00

## Contract Item Sheets For C204053

Line #	ItemNumber	Sec #	Description	Quantity Unit	Unit Bid Price	Amount Bid
0064	8860000000-N	SP	GENERIC STRUCTURE ITEM PAINTING EXISTING WEATHERING STEEL STRUCTURE FOR BRIDGE NO 493	Lump Sum LS	55,000.00	55,000.00
0065	8860000000-N	SP	GENERIC STRUCTURE ITEM PAINTING EXISTING WEATHERING STEEL STRUCTURE FOR BRIDGE NO 494	Lump Sum LS	55,000.00	55,000.00
0066	8860000000-N	SP	GENERIC STRUCTURE ITEM ZONE PAINTING OF EXISTING STRUCTURE FOR BRIDGE NO 474	Lump Sum LS	25,000.00	25,000.00
0067	8867000000-E	SP	GENERIC STRUCTURE ITEM SILICONE JOINT SEALANT	1,499.9 LF	60.00	89,994.00
0068	8882000000-E	SP	GENERIC STRUCTURE ITEM ELASTOMERIC CONCRETE	769.6 CF	300.00	230,880.00
0069	8892000000-E	SP	GENERIC STRUCTURE ITEM BRIDGE JOINT DEMOLITION	3,107.9 SF	100.00	310,790.00
0070	8892000000-E	SP	GENERIC STRUCTURE ITEM CONCRETE DECK REPAIR FOR EPOXY OVERLAY	60 SF	350.00	21,000.00
0071	8892000000-E	SP	GENERIC STRUCTURE ITEM EPOXY OVERLAY SYSTEM	144,297.4 SF	6.00	865,784.40
0072	8897000000-N	SP	GENERIC STRUCTURE ITEM CLEANING & PAINTING EXISTING BEARINGS WITH HRCSA FOR BRIDGE NO 474	48 EA	650.00	31,200.00
0073	8897000000-N	SP	GENERIC STRUCTURE ITEM CLEANING & PAINTING EXISTING BEARINGS WITH HRCSA FOR BRIDGE NO 479	48 EA	650.00	31,200.00
0074	8897000000-N	SP	GENERIC STRUCTURE ITEM CLEANING & PAINTING EXISTING BEARINGS WITH HRCSA FOR BRIDGE NO 480	48 EA	650.00	31,200.00
0075	8897000000-N	SP	GENERIC STRUCTURE ITEM CLEANING & PAINTING EXISTING BEARINGS WITH HRCSA FOR BRIDGE NO 485	48 EA	650.00	31,200.00
0076	8897000000-N	SP	GENERIC STRUCTURE ITEM CLEANING & PAINTING EXISTING BEARINGS WITH HRCSA FOR BRIDGE NO 489	80 EA	650.00	52,000.00

## Contract Item Sheets For C204053

Line #	ItemNumber	Sec #	Description	Quantity Unit	Unit Bid Price	Amount Bid
0077	8897000000-N	SP	GENERIC STRUCTURE ITEM CLEANING & PAINTING EXISTING BEARINGS WITH HRCSA FOR BRIDGE NO 493	48 EA	650.00	31,200.00
0078	8897000000-N	SP	GENERIC STRUCTURE ITEM CLEANING & PAINTING EXISTING BEARINGS WITH HRCSA FOR BRIDGE NO 494	48 EA	650.00	31,200.00
<b>TOTAL AMOUNT OF BID FOR ENTIRE PROJECT</b>						<b>\$17,171,809.92</b>

1016/Jan30/Q2128837.51/D415371210000/E78



Contract No. C204053  
County DAVIDSON

Rev. 1-16-18

**EXECUTION OF CONTRACT  
NON-COLLUSION, DEBARMENT AND GIFT BAN CERTIFICATION**

**CORPORATION**

The Contractor declares (or certifies, verifies, or states) under penalty of perjury under the laws of the United States that neither he, nor any official, agent or employee has entered into any agreement, participated in any collusion, or otherwise taken any action which is in restraint of free competitive bidding in connection with this Contract, that the Contractor has not been convicted of violating N.C.G.S. § 133-24 within the last three years, and that the Contractor intends to do the work with its own bonafide employees or subcontractors and did not bid for the benefit of another contractor.

By submitting this Execution of Contract, Non-Collusion and Debarment Certification, the Contractor is certifying his status under penalty of perjury under the laws of the United States in accordance with the Debarment Certification attached, provided that the Debarment Certification also includes any required statements concerning exceptions that are applicable.

N.C.G.S. § 133-32 and Executive Order 24 prohibit the offer to, or acceptance by, any State Employee of any gift from anyone with a contract with the State, or from any person seeking to do business with the State. By execution of any response in this procurement, you attest, for your entire organization and its employees or agents, that you are not aware that any such gift has been offered, accepted, or promised by any employees of your organization.

**SIGNATURE OF CONTRACTOR**

Triangle Grading & Paving, Inc.  
Full name of Corporation

PO Drawer 2570, Burlington, NC 27216-2570  
Address as Prequalified

Attest Christine V Isaac By [Signature]  
~~Secretary/Assistant Secretary~~ ~~President/Vice President/Assistant Vice President~~  
Select appropriate title

Christine V Isaac  
Print or type Signer's name

RG Kirkpatrick Jr.  
Print or type Signer's name

**CORPORATE SEAL**



## DEBARMENT CERTIFICATION

### Conditions for certification:

1. The prequalified bidder shall provide immediate written notice to the Department if at any time the bidder learns that his certification was erroneous when he submitted his debarment certification or explanation filed with the Department, or has become erroneous because of changed circumstances.
2. The terms *covered transaction, debarred, suspended, ineligible, lower tier covered transaction, participant, person, primary covered transaction, principal, proposal, and voluntarily excluded*, as used in this provision, have the meanings set out in the Definitions and Coverage sections of the rules implementing Executive Order 12549. A copy of the Federal Rules requiring this certification and detailing the definitions and coverages may be obtained from the Contract Officer of the Department.
3. The prequalified bidder agrees by submitting this form, that he will not knowingly enter into any lower tier covered transaction with a person who is debarred, suspended, declared ineligible, or voluntarily excluded from participation in NCDOT contracts, unless authorized by the Department.
4. For Federal Aid projects, the prequalified bidder further agrees that by submitting this form he will include the Federal-Aid Provision titled *Required Contract Provisions Federal-Aid Construction Contract (Form FHWA PR 1273)* provided by the Department, without subsequent modification, in all lower tier covered transactions.
5. The prequalified bidder may rely upon a certification of a participant in a lower tier covered transaction that he is not debarred, suspended, ineligible, or voluntarily excluded from the covered transaction, unless he knows that the certification is erroneous. The bidder may decide the method and frequency by which he will determine the eligibility of his subcontractors.
6. Nothing contained in the foregoing shall be construed to require establishment of a system of records in order to render in good faith the certification required by this provision. The knowledge and information of a participant is not required to exceed that which is normally possessed by a prudent person in the ordinary course of business dealings.
7. Except as authorized in paragraph 6 herein, the Department may terminate any contract if the bidder knowingly enters into a lower tier covered transaction with a person who is suspended, debarred, ineligible, or voluntarily excluded from participation in this transaction, in addition to other remedies available by the Federal Government.

### DEBARMENT CERTIFICATION

The prequalified bidder certifies to the best of his knowledge and belief, that he and his principals:

- a. Are not presently debarred, suspended, proposed for debarment, declared ineligible, or voluntarily excluded from covered transactions by any Federal department or agency;
- b. Have not within a three-year period preceding this proposal been convicted of or had a civil judgment rendered against them for commission of fraud or a criminal offense in connection with obtaining, attempting to obtain, or performing a public (Federal, State or local) transaction or contract under a public transaction; violation of Federal or State antitrust statutes or commission of embezzlement, theft, forgery, bribery, falsification or destruction of records; making false statements; or receiving stolen property;
- c. Are not presently indicted for or otherwise criminally or civilly charged by a governmental entity (Federal, State or local) with commission of any of the offenses enumerated in paragraph b. of this certification; and
- d. Have not within a three-year period preceding this proposal had one or more public transactions (Federal, State or local) terminated for cause or default.
- e. Will submit a revised Debarment Certification immediately if his status changes and will show in his bid proposal an explanation for the change in status.

If the prequalified bidder cannot certify that he is not debarred, he shall provide an explanation with this submittal. An explanation will not necessarily result in denial of participation in a contract.

Failure to submit a non-collusion and debarment certification will result in the prequalified bidder's bid being considered non-responsive.

Check here if an explanation is attached to this certification.

**Contract No.**     **C204053**

**County (ies):**    **Davidson**

ACCEPTED BY THE  
DEPARTMENT OF TRANSPORTATION

DocuSigned by:  
*Ronald E. Davenport, Jr.*  
F81B6038A47A442...  
\_\_\_\_\_  
Contract Officer

2/7/2018  
\_\_\_\_\_  
Date

Execution of Contract and Bonds  
Approved as to Form:

DocuSigned by:  
*Scott Slusser*  
06A61E7CD374498...  
\_\_\_\_\_  
Attorney General

2/7/2018  
\_\_\_\_\_  
Date

Signature Sheet (Bid - Acceptance by Department)

Bond No. 9275865

Contract No. C204053  
County Davidson

Rev 5-17-11

### CONTRACT PAYMENT BOND

Date of Payment Bond Execution January 26, 2018

Name of Principal Contractor Triangle Grading & Paving, Inc.

Name of Surety: Zurich American Insurance Company / Fidelity and Deposit Company of Maryland  
Contract Surety Bond Claims, c/o ZURICH, 1299 Zurich Way, Schaumburg, IL 60196-1056

Name of Contracting Body: North Carolina Department of Transportation  
Raleigh, North Carolina

Amount of Bond: \$17,171,809.92 Seventeen Million One Hundred Seventy One  
Thousand Eight Hundred Nine Dollars and 92/100

Contract ID No.: C204053

County Name: Davidson

KNOW ALL MEN BY THESE PRESENTS, That we, the PRINCIPAL CONTRACTOR (hereafter, PRINCIPAL) and SURETY above named, are held and firmly bound unto the above named Contracting Body, hereinafter called the Contracting Body, in the penal sum of the amount stated above for the payment of which sum well and truly to be made, we bind ourselves, our heirs, executors, administrators, and successors, jointly and severally, firmly by these presents.

THE CONDITION OF THIS OBLIGATION IS SUCH, that whereas the principal entered into a certain contract with the Contracting Body, numbered as shown above and hereto attached:

NOW THEREFORE, if the principal shall promptly make payment to all persons supplying labor and material in the prosecution of the work provided for in said contract, and any and all duly authorized modifications of said contract that may hereafter be made, notice of which modifications to the surety being hereby waived, then this obligation to be void; otherwise to remain in full force and virtue.

IN WITNESS WHEREOF, the above-bound parties have executed this instrument under their several seals on the date indicated above, the name and corporate seal of each corporate party being hereto affixed and these presents duly signed by its undersigned representative, pursuant to authority of its governing body.

Contract No. C204053  
County Davidson

Rev 5-17-11

### CONTRACT PAYMENT BOND

*Affix Seal of Surety Company*

Zurich American Insurance Company /  
Fidelity and Deposit Company of Maryland  
Print or type Surety Company Name

By Angela M. Yount  
Print, stamp or type name of Attorney-in-Fact

Angela M. Yount  
Signature of Attorney-in-Fact

Surety Phone No. / 847-604-8000

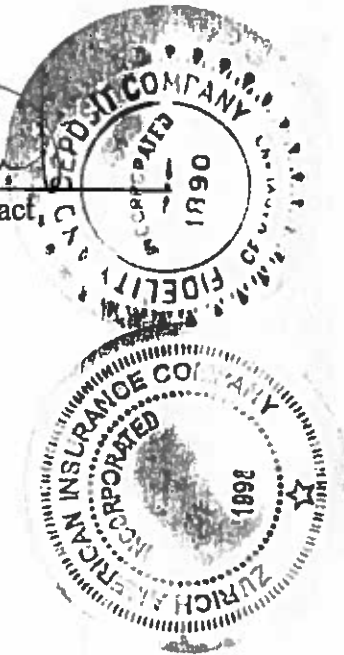

Wendy E. Lahm  
Signature of Witness

Wendy E. Lahm  
Print or type Signer's name

5605 Carnegie Boulevard, Suite 300  
Charlotte, NC 28209  
Address of Attorney-in-Fact

Contract No. C204053  
County Davidson

Rev 5-17-11

**CONTRACT PAYMENT BOND**

**CORPORATION**

SIGNATURE OF CONTRACTOR (Principal)

Triangle Grading & Paving, Inc.  
Full name of Corporation

PO Drawer 2570, Burlington, NC 27216-2570  
Address as prequalified

By   
Signature of ~~President~~, Vice President, Assistant ~~Vice President~~  
Select appropriate title

RG Kirkpatrick Jr.  
Print or type Signer's name

*Affix Corporate Seal*

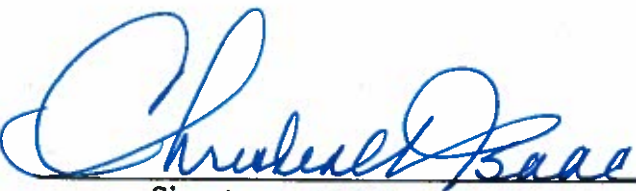

Attest   
Signature of ~~Secretary~~, Assistant Secretary  
Select appropriate title

Christine V Isaac  
Print or type Signer's name

Contract No. C204053  
 County Davidson

### CONTRACT PERFORMANCE BOND

Date of Performance Bond Execution: January 26, 2018

Name of Principal Contractor: Triangle Grading & Paving, Inc.

Name of Surety: Zurich American Insurance Company / Fidelity and Deposit Company of Maryland  
 Contract Surety Bond Claims, c/o ZURICH, 1299 Zurich Way, Schaumburg, IL 60196-1056

Name of Contracting Body: North Carolina Department of Transportation  
Raleigh, North Carolina

Amount of Bond: \$17,171,809.92 Seventeen Million One Hundred Seventy One  
 Thousand Eight Hundred Nine Dollars and 92/100

Contract ID No.: C204053

County Name: Davidson

KNOW ALL MEN BY THESE PRESENTS, That we, the PRINCIPAL CONTRACTOR (hereafter, PRINCIPAL) and SURETY above named, are held and firmly bound unto the above named Contracting Body, hereinafter called the Contracting Body, in the penal sum of the amount stated above for the payment of which sum well and truly to be made, we bind ourselves, our heirs, executors, administrators, and successors, jointly and severally, firmly by these presents.

THE CONDITION OF THIS OBLIGATION IS SUCH, that whereas the principal entered into a certain contract with the Contracting Body, numbered as shown above and hereto attached:

NOW THEREFORE, if the principal shall well and truly perform and fulfill all the undertakings, covenants, terms, conditions, and agreements of said contract during the original term of said contract and any extensions thereof that may be granted by the Contracting Body, with or without notice to the Surety, and during the life of any guaranty required under the contract, and shall also well and truly perform and fulfill all the undertakings, covenants, terms, conditions, and agreements of any and all duly authorized modifications of said contract that may hereafter be made, notice of which modifications to the surety being hereby waived, then this obligation to be void; otherwise to remain in full force and virtue.

IN WITNESS WHEREOF, the above-bound parties have executed this instrument under their several seals on the date indicated above, the name and corporate seal of each corporate party being hereto affixed and these presents duly signed by its undersigned representative, pursuant to authority of its governing body.



Contract No. C204053  
County Davidson

Rev 5-17-11

### CONTRACT PERFORMANCE BOND

*Affix Seal of Surety Company*

Zurich American Insurance Company /  
Fidelity and Deposit Company of Maryland  
Print or type Surety Company Name

By Angela M. Yount  
Print, stamp or type name of Attorney-in-Fact

Angela M. Yount  
Signature of Attorney-in-Fact

Surety Phone No. / 847-604-6000

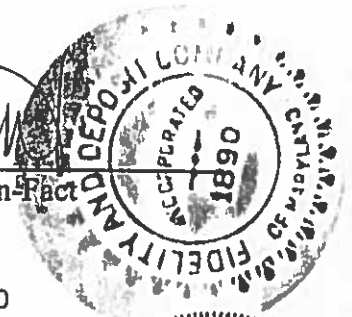

Wendy E. Lahm  
Signature of Witness

Wendy E. Lahm  
Print or type Signer's name

5605 Carnegie Boulevard, Suite 300

Charlotte, NC 28209

Address of Attorney-in-Fact

Contract No. C204053  
County Davidson

Rev 5-17-11

**CONTRACT PERFORMANCE BOND**

**CORPORATION**

SIGNATURE OF CONTRACTOR (Principal)

Triangle Grading & Paving, Inc.  
Full name of Corporation

PO Drawer 2570, Burlington, NC 27216-2570  
Address as prequalified

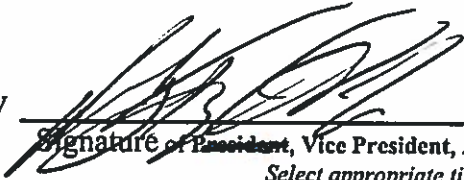
By   
Signature of ~~President, Vice President, Assistant Vice President~~  
Select appropriate title

RG Kirkpatrick Jr.  
Print or type Signer's name

*Affix Corporate Seal*

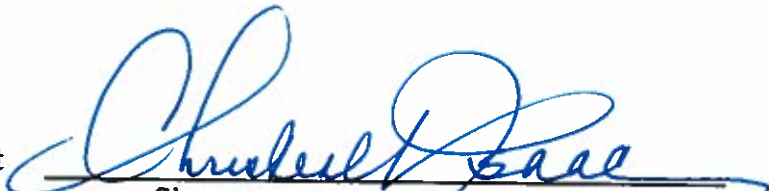

Attest   
Signature of ~~Secretary, Assistant Secretary~~  
Select appropriate title

Christine V Isaac  
Print or type Signer's name

**ZURICH AMERICAN INSURANCE COMPANY  
COLONIAL AMERICAN CASUALTY AND SURETY COMPANY  
FIDELITY AND DEPOSIT COMPANY OF MARYLAND  
POWER OF ATTORNEY**

KNOW ALL MEN BY THESE PRESENTS: That the ZURICH AMERICAN INSURANCE COMPANY, a corporation of the State of New York, the COLONIAL AMERICAN CASUALTY AND SURETY COMPANY, a corporation of the State of Maryland, and the FIDELITY AND DEPOSIT COMPANY OF MARYLAND a corporation of the State of Maryland (herein collectively called the "Companies"), by **MICHAEL BOND**, Vice President, in pursuance of authority granted by Article V, Section 8, of the By-Laws of said Companies, which are set forth on the reverse side hereof and are hereby certified to be in full force and effect on the date hereof, do hereby nominate, constitute, and appoint **Raymond J. GARRUTO, Debra S. RITTER, Martin D. PALLAZZA, Brad W. GIBSON, Angela M. YOUNT, Jenny SNELL, H. Thomas DAWKINS, Robert C. TRESHER and Wendy E. LAHM**, all of Charlotte, North Carolina, EACH its true and lawful agent and Attorney-in-Fact, to make, execute, seal and deliver, for, and on its behalf as surety, and as its act and deed: any and all bonds and undertakings, and the execution of such bonds or undertakings in pursuance of these presents, shall be as binding upon said Companies, as fully and amply, to all intents and purposes, as if they had been duly executed and acknowledged by the regularly elected officers of the ZURICH AMERICAN INSURANCE COMPANY at its office in New York, New York., the regularly elected officers of the COLONIAL AMERICAN CASUALTY AND SURETY COMPANY at its office in Owings Mills, Maryland., and the regularly elected officers of the FIDELITY AND DEPOSIT COMPANY OF MARYLAND at its office in Owings Mills, Maryland., in their own proper persons.

The said Vice President does hereby certify that the extract set forth on the reverse side hereof is a true copy of Article V, Section 8, of the By-Laws of said Companies, and is now in force.

IN WITNESS WHEREOF, the said Vice-President has hereunto subscribed his/her names and affixed the Corporate Seals of the said ZURICH AMERICAN INSURANCE COMPANY, COLONIAL AMERICAN CASUALTY AND SURETY COMPANY, and FIDELITY AND DEPOSIT COMPANY OF MARYLAND, this 15th day of January, A.D. 2018.

ATTEST:

**ZURICH AMERICAN INSURANCE COMPANY  
COLONIAL AMERICAN CASUALTY AND SURETY COMPANY  
FIDELITY AND DEPOSIT COMPANY OF MARYLAND**



By: *Dawn E. Brown*  
Assistant Secretary  
Dawn E. Brown

*Michael Bond*  
Vice President  
Michael Bond

State of Maryland  
County of Baltimore

On this 15th day of January, A.D. 2018, before the subscriber, a Notary Public of the State of Maryland, duly commissioned and qualified, **MICHAEL BOND**, Vice President, and **DAWN E. BROWN**, Assistant Secretary, of the Companies, to me personally known to be the individuals and officers described in and who executed the preceding instrument, and acknowledged the execution of same, and being by me duly sworn, deposeth and saith, that he/she is the said officer of the Company aforesaid, and that the seals affixed to the preceding instrument are the Corporate Seals of said Companies, and that the said Corporate Seals and the signature as such officer were duly affixed and subscribed to the said instrument by the authority and direction of the said Corporations.

IN TESTIMONY WHEREOF, I have hereunto set my hand and affixed my Official Seal the day and year first above written.

*Constance A. Dunn*

Constance A. Dunn, Notary Public  
My Commission Expires: July 9, 2019



EXTRACT FROM BY-LAWS OF THE COMPANIES

"Article V, Section 8, Attorneys-in-Fact. The Chief Executive Officer, the President, or any Executive Vice President or Vice President may, by written instrument under the attested corporate seal, appoint attorneys-in-fact with authority to execute bonds, policies, recognizances, stipulations, undertakings, or other like instruments on behalf of the Company, and may authorize any officer or any such attorney-in-fact to affix the corporate seal thereto; and may with or without cause modify or revoke any such appointment or authority at any time."

CERTIFICATE

I, the undersigned, Vice President of the ZURICH AMERICAN INSURANCE COMPANY, the COLONIAL AMERICAN CASUALTY AND SURETY COMPANY, and the FIDELITY AND DEPOSIT COMPANY OF MARYLAND, do hereby certify that the foregoing Power of Attorney is still in full force and effect on the date of this certificate; and I do further certify that Article V, Section 8, of the By-Laws of the Companies is still in force.

This Power of Attorney and Certificate may be signed by facsimile under and by authority of the following resolution of the Board of Directors of the ZURICH AMERICAN INSURANCE COMPANY at a meeting duly called and held on the 15th day of December 1998.

RESOLVED: "That the signature of the President or a Vice President and the attesting signature of a Secretary or an Assistant Secretary and the Seal of the Company may be affixed by facsimile on any Power of Attorney...Any such Power or any certificate thereof bearing such facsimile signature and seal shall be valid and binding on the Company."

This Power of Attorney and Certificate may be signed by facsimile under and by authority of the following resolution of the Board of Directors of the COLONIAL AMERICAN CASUALTY AND SURETY COMPANY at a meeting duly called and held on the 5th day of May, 1994, and the following resolution of the Board of Directors of the FIDELITY AND DEPOSIT COMPANY OF MARYLAND at a meeting duly called and held on the 10th day of May, 1990.

RESOLVED: "That the facsimile or mechanically reproduced seal of the company and facsimile or mechanically reproduced signature of any Vice-President, Secretary, or Assistant Secretary of the Company, whether made heretofore or hereafter, wherever appearing upon a certified copy of any power of attorney issued by the Company, shall be valid and binding upon the Company with the same force and effect as though manually affixed.

IN TESTIMONY WHEREOF, I have hereunto subscribed my name and affixed the corporate seals of the said Companies  
this 26th day of January, 2018.

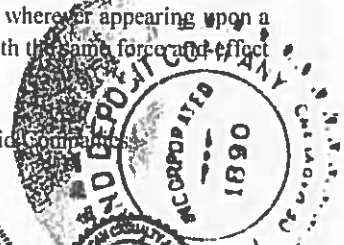

David McVicker, Vice President

TO REPORT A CLAIM WITH REGARD TO A SURETY BOND, PLEASE SUBMIT ALL REQUIRED INFORMATION TO:

Zurich American Insurance Co.  
Attn: Surety Claims  
1299 Zurich Way  
Schaumburg, IL 60196-1056